

TM 10-5430-267-13&P

TECHNICAL MANUAL

OPERATOR AND FIELD MAINTENANCE MANUAL
INCLUDING REPAIR PARTS AND SPECIAL TOOLS LIST
FOR
TANK, FABRIC, COLLAPSIBLE, FUEL STORAGE
20,000 GALLON, MODEL MPC-F-20K-22276
(NSN 5430-01-473-2321) (EIC: 6GR)

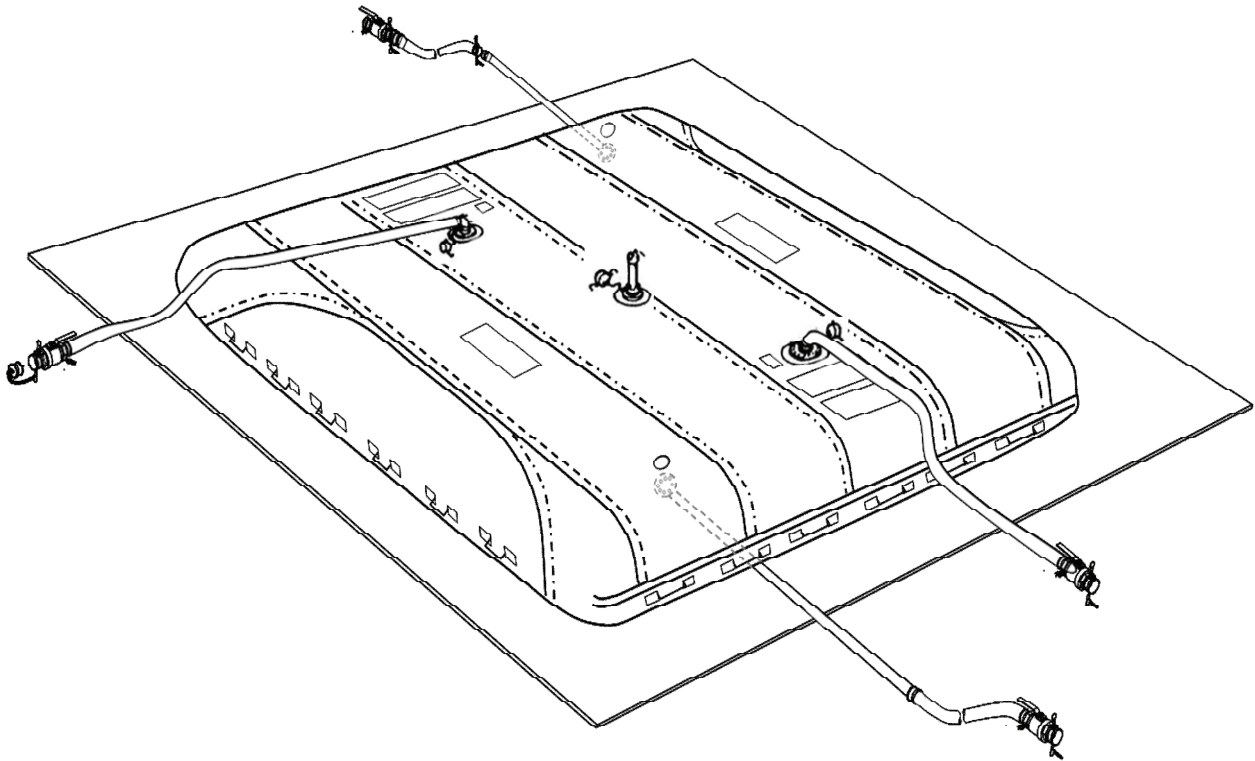

DISTRIBUTION STATEMENT A – Approved for public release; distribution is unlimited.

HEADQUARTERS, DEPARTMENT OF THE ARMY
APRIL 2009

WARNING SUMMARY

This warning summary contains general safety warnings and hazardous materials warnings that must be understood and applied during operation and maintenance of this equipment. Failure to observe these precautions could result in serious injury or death to personnel.

FIRST AID DATA

First aid instructions are given in FM 4-25.11, First Aid.

GENERAL SAFETY WARNINGS DESCRIPTION

WARNING

Do not allow smoking within 100 feet (30.50 meters) of the storage area. Death or serious injury may result if personnel fail to strictly observe safety precautions.

Avoid spillage of fuel. When spillage occurs, start immediate cleanup of the affected area. Specific requirements and guidance is provided in the unit's Spill Prevention, Control, and Countermeasures (SPCC) plan. Failure to observe this warning may result in death or serious injury.

Position fire extinguishers at readily accessible positions round the tank(s). Failure to observe this warning may result in death or serious injury.

Avoid getting fuel on the body or clothing. If clothing becomes saturated, remove it immediately and wash the body thoroughly with soapy water. Failure to observe this warning may result in death or serious injury.

Safety berms must have capacities of less than one and one-half times that of tank capacities. Failure to construct a secure safety berm may result in death or serious injury.

Dry cleaning solvent, A-A-59601, used to clean parts, is potentially dangerous to personnel and property. It produces toxic and flammable fumes. Use only in well-ventilated areas. Avoid repeated and prolonged skin contact. Do not use near an open flame or excessive heat. The flash point of solvent is 100°F to 138°F (38°C to 59°C). Failure to observe these precautions may result in death or serious injury to personnel.

Sludge that accumulates in the bottom of the fuel tank gives off toxic and explosive vapors. Inhaling these vapors can cause lead poisoning. When cleaning tanks, provide ample ventilation to carry off harmful fumes. Failure to observe these precautions may result in death or serious injury to personnel.

Always wear protective goggles, breathing apparatus, and other protective gear when cleaning the tank interior. Fuel vapors are toxic and can damage eyes, skin, and lungs.

Fuel vapors are extremely flammable. Exercise care to prevent sparks when working near or in the tank. Death or severe personal injury can result if safety precautions are not strictly observed.

GENERAL SAFETY WARNINGS DESCRIPTION – CONTINUED

WARNING

Make certain that the Berm Liner Drain Ball Valve Assembly is closed and locked after installation and after draining the berm. In the event of tank rupture, an open valve would permit fuel to drain from the berm. Undetected fuel leakage could result in an explosion and cause death, severe personal injury, and damage to equipment.

Make sure the Berm Liner Drain Ball Valve Assembly handle has been rotated fully to the closed position before filling the tank. Undetected draining of the tank could result in an explosion that can cause death or severe personal injury.

Be careful when installing a sealing clamp in the tank. Fuel will pour out when a larger slit is made. Leaking fuel can cause personal injury and loss of Government property.

Chemical solvents used for cleaning detached Tank Assembly accessories, exposed fasteners, and other metallic parts (when parts have been removed from the installation site) are flammable and toxic to skin, eyes, and the respiratory tract. Skin and eye protection are required. Use chemical solvents in a well ventilated area. Failure to observe these precautions may result in death or serious injury to personnel.

Filler Assembly must be tight. Under pressure, coupling may burst and cause personal injury.

Confined Space –The Tank Envelope is a permit required confined space. Do not enter tank envelope, suffocation could result.

Lifting or moving heavy equipment incorrectly can cause serious injury. Do not lift or move more than 50 lb (22.7 kg) alone. Always get help from additional personnel during lifting operations.

Do not exceed maximum fill capacity. Tank Envelope may burst if overfilled, causing injury or death to personnel.

CHEMICAL, BIOLOGICAL, RADIOLOGICAL, OR NUCLEAR (CBRN)

In the event equipment has been exposed to chemical, biological, radiological, or nuclear warfare, the equipment shall be handled with extreme caution and decontaminated in accordance with FM 3-11.5, NBC Decontamination. Unprotected personnel can experience injury or death if residual toxic agents or radioactive material are present. If equipment is exposed to chemical, biological, radiological, or nuclear agents, personnel must wear protective mask, hood, protective overgarments, chemical gloves and chemical boots in accordance with the MOPP level prescribed by the OIC or NCOIC.

ICE BUILDUP

Cold weather operations could create ice buildup on exposed surfaces producing hazardous footing conditions. Use extreme care when operating under icing conditions. Death or serious injury to personnel could occur.

LIST OF EFFECTIVE PAGES / WORK PACKAGES

NOTE: Zero in the "Change No." column indicates an original page or work package.

Date of issue for the original manual is:

Original 15 April 2009

TOTAL NUMBER OF PAGES FOR FRONT AND REAR MATTER IS 22 AND TOTAL NUMBER OF WORK PACKAGES IS 76 CONSISTING OF THE FOLLOWING:

Page / WP No.	Change No.	Page / WP No.	Change No.
Front Cover	0	Chp 6 title page	0
c/d	0	WP 0037 (2 pgs)	0
Chp 1 title page	0	WP 0038 (2 pgs)	0
WP 0001 (4 pgs)	0	WP 0039 (2 pgs)	0
WP 0002 (6 pgs)	0	WP 0040 (4 pgs)	0
WP 0003 (2 pgs)	0	WP 0041 (4 pgs)	0
Chp 2 title page	0	WP 0042 (2 pgs)	0
WP 0004 (2 pgs)	0	WP 0043 (4 pgs)	0
WP 0005 (16 pgs)	0	WP 0044 (4 pgs)	0
WP 0006 (6 pgs)	0	WP 0045 (4 pgs)	0
Chp 3 title page	0	WP 0046 (2 pgs)	0
WP 0007 (2 pgs)	0	WP 0047 (2 pgs)	0
WP 0008 (2 pgs)	0	WP 0048 (2 pgs)	0
WP 0009 (2 pgs)	0	WP 0049 (2 pgs)	0
WP 0010 (2 pgs)	0	WP 0050 (4 pgs)	0
WP 0011 (2 pgs)	0	WP 0051 (2 pgs)	0
WP 0012 (2 pgs)	0	Chp 7 title page	0
WP 0013 (2 pgs)	0	WP 0052 (6 pgs)	0
WP 0014 (2 pgs)	0	WP 0053 (4 pgs)	0
WP 0015 (2 pgs)	0	WP 0054 (4 pgs)	0
WP 0016 (2 pgs)	0	WP 0055 (4 pgs)	0
WP 0017 (2 pgs)	0	WP 0056 (4 pgs)	0
WP 0018 (2 pgs)	0	WP 0057 (4 pgs)	0
WP 0019 (2 pgs)	0	WP 0058 (4 pgs)	0
WP 0020 (2 pgs)	0	WP 0059 (4 pgs)	0
Chp 4 title page	0	WP 0060 (4 pgs)	0
WP 0021 (2 pgs)	0	WP 0061 (4 pgs)	0
WP 0022 (6 pgs)	0	WP 0062 (4 pgs)	0
WP 0023 (2 pgs)	0	WP 0063 (4 pgs)	0
WP 0024 (2 pgs)	0	WP 0064 (4 pgs)	0
WP 0025 (2 pgs)	0	WP 0065 (4 pgs)	0
Chp 5 title page	0	WP 0066 (4 pgs)	0
WP 0026 (2 pgs)	0	WP 0067 (4 pgs)	0
WP 0027 (2 pgs)	0	WP 0068 (4 pgs)	0
WP 0028 (2 pgs)	0	WP 0069 (2 pgs)	0
WP 0029 (2 pgs)	0	WP 0070 (2 pgs)	0
WP 0030 (2 pgs)	0	Chp 8 title page	0
WP 0031 (2 pgs)	0	WP 0071 (2 pgs)	0
WP 0032 (2 pgs)	0	WP 0072 (4 pgs)	0
WP 0033 (2 pgs)	0	WP 0073 (4 pgs)	0
WP 0034 (2 pgs)	0	WP 0074 (8 pgs)	0
WP 0035 (2 pgs)	0	WP 0075 (2 pgs)	0
WP 0036 (2 pgs)	0	WP 0076 (2 pgs)	0

HEADQUARTERS,
DEPARTMENT OF THE ARMY
WASHINGTON, D.C., 15 APRIL 2009

TECHNICAL MANUAL

OPERATOR AND FIELD MAINTENANCE MANUAL
INCLUDING
REPAIR PARTS AND SPECIAL TOOLS LIST
FOR
TANK, FABRIC, COLLAPSIBLE, FUEL STORAGE
20,000 GALLON
MODEL MPC-F-20K-22276
(NSN 5430-01-473-2321) (EIC: 6GR)

REPORTING ERRORS AND RECOMMENDING IMPROVEMENTS

You can help improve this publication. If you find any errors or if you would like to recommend any improvements to the procedures in this publication, please let us know. The preferred method is to submit your DA Form 2028 (Recommended Changes to Publications and Blank Forms) through the Internet on the Army Electronic Product Support (AEPS) Web site. The Internet address is <https://aeprs.ria.army.mil>. The DA Form 2028 is located under the Public Applications section on the AEPS public home page. Fill out the form and click on SUBMIT. Using this form on the AEPS site will enable us to respond to your comments quicker and to manage the DA Form 2028 program better. You may also mail, e-mail, or fax your comments or DA Form 2028 directly to the U.S. Army TACOM Life Cycle Management Command. The postal address is U.S. Army TACOM Life Cycle Management Command, ATTN: AMSTA-LC-LMPP / TECH PUBS, 1 Rock Island Arsenal, Rock Island, IL 61299-7630. The e-mail address is tacomlcmc.daform2028@us.army.mil. The fax number is DSN 793-0726 or Commercial (309) 782-0726.

DISTRIBUTION STATEMENT A – Approved for public release; distribution is unlimited.

TABLE OF CONTENTS

	<u>Page No .</u>	<u>WP Sequence No.</u>
List of Effective Pages	A	
How to Use This Manual	viii	
Chapter 1 - General Information, Equipment Description and Theory of Operation for Tank, Fabric, Collapsible, Fuel Storage 20,000 Gallon		
General Information	0001	
Equipment Description and Data.....	0002	
Figure 1. Tank Assembly.....	0002-1	
Table 1. Major Components	0002-2	
Table 2. Tank Assembly Specifications.....	0002-3	
Table 3. Strapping Chart – After 24 Hours Filled	0002-4	
Theory of Operation.....	0003	
Chapter 2 - Operator Instructions for Tank, Fabric, Collapsible, Fuel Storage 20,000 Gallon		
Description and Use of Operator Controls and Indicators	0004	
Figure 1. Controls and Indicators	0004-1	
Table 1. Controls and Indicators	0004-1	
Operation Under Usual Conditions	0005	
Figure 1. Shipping Container Layout.....	0005-1	
Table 1. Tank Assembly Components in Shipping Container	0005-2	
Table 2. Berm Liner Components in Shipping Container	0005-2	
Figure 2. Berm Liner Drain Hose Assembly, Bowl x Cam, Cam x Cam, and Drain Ball Valve.	0005-3	
Figure 3. Position Tank Envelope	0005-4	
Figure 4. Unroll Tank Envelope.....	0005-4	
Figure 5. Unfold Tank Envelope.....	0005-5	
Figure 6. Tank Drain Hose Assembly, Bowl x Cam, Cam x Cam, and Drain Ball Valve.	0005-5	
Figure 7. Dust Cap Removal	0005-6	
Figure 8. Vent Port Assembly.....	0005-7	
Figure 9. Filler/Discharge Elbow	0005-8	
Figure 10. Filler/Discharge Hose Assembly and Shutoff Valve from Fuel Source Host System	0005-9	

TABLE OF CONTENTS

	<u>Page No .</u>	<u>WP Sequence No.</u>
Figure 11. Elevated Connections	0005-10	
Figure 12. Tank Envelope Folding Procedures	0005-13	
Figure 13. Tank Envelope Folding	0005-14	
Figure 14. Berm Liner Folding	0005-15	
Operation Under Usual Conditions and Emergency Repair Procedures		0006
Figure 1. Tank Envelope Restraining Straps	0006-2	
Figure 2. Wood Plug Installation	0006-3	
Figure 3. Mechanical Patch Installation	0006-4	
Chapter 3 - Operator Troubleshooting Procedures for Tank, Fabric, Collapsible, Fuel Storage 20,000 Gallon		
Master Malfunction/Symptom Index		0007
Tank Assembly Operational Checkout		0008
Tank Assembly Leakage		0009
Shutoff Valve from Fuel Source Host System		0010
Filler/Discharge Hose Assembly		0011
Tank Drain Ball Valve Assembly		0012
Tank Drain Hose Assembly		0013
Vent Port Assembly		0014
Cap and Flame Arrestor Assembly, Passive Vent		0015
Filler/Discharge Assembly		0016
Tank Drain Fitting Assembly		0017
Berm Liner Drain Fitting Assembly		0018
Berm Liner Drain Ball Valve Assembly		0019
Emergency Repair Kit and Spare Parts		0020
Chapter 4 - Operator Maintenance Instructions for Tank, Fabric, Collapsible, Fuel Storage 20,000 Gallon		
Preventive Maintenance Checks and Services (PMCS) Introduction		0021
Preventive Maintenance Checks and Services (PMCS) and Lubrication Procedures		0022
Table 1. Preventive Maintenance Checks and Services (PMCS)		0022-2

TABLE OF CONTENTS

	<u>WP Sequence No.</u>
	<u>Page No .</u>
Tank/Berm Liner Drain Ball Valve Assembly.....	0023
Figure 1. Tank/Berm Liner Ball Valve Assembly.....	0023-1
Vent Port Assembly Repair	0024
Figure 1. Vent Port Assembly.....	0024-1
Filler/Discharge Assembly Repair	0025
Figure 1. Filler/Discharge Assembly.....	0025-1
 Chapter 5 - Field Maintenance Troubleshooting Procedures for Tank, Fabric, Collapsible, Fuel Storage 20,000 Gallon	
Master Malfunction/Symptom Index	0026
Shutoff Valve from Fuel Source Host System	0027
Filler/Discharge Hose Assembly.....	0028
Tank or Berm Liner Drain Ball Valve Assembly	0029
Tank Drain Hose Assembly	0030
Vent Port Assembly	0031
Cap and Flame Arrestor Assembly, Passive Vent	0032
Filler/Discharge Assembly	0033
Tank Drain Fitting Assembly.....	0034
Berm Liner Drain Fitting Assembly	0035
Berm Liner Drain Hose Assembly, Bowl x Cam and Cam x Cam.....	0036
 Chapter 6 – Field Maintenance Instructions for Tank, Fabric, Collapsible, Fuel Storage 20,000 Gallon	
Service Upon Receipt of Materiel.....	0037
Table 1. Equipment Inspection.....	0037-2
Preventive Maintenance Checks and Services (PMCS) Introduction	0038
Preventive Maintenance Checks and Services (PMCS) and Lubrication Procedures	0039
Table 1. Preventive Maintenance Checks and Services (PMCS).....	0039-1
Filler/Discharge Hose Assembly.....	0040
Figure 1. Filler/Discharge Hose Assembly	0040-2
Tank or Berm Liner Ball Valve Assembly Service and Repair	0041
Figure 1. Tank or Berm Liner Drain Valve.....	0041-1

TABLE OF CONTENTS

	<u>WP Sequence No.</u>
	<u>Page No.</u>
Tank Drain Hose Assembly, Bowl x Cam Service and Repair	0042
Figure 1. Tank Drain Hose Assembly, Bowl x Cam ..	0042-1
Tank Drain Hose Assembly, Cam x Cam Service and Repair	0043
Figure 1. Tank Drain Hose Assembly, Cam x Cam ..	0043-2
Vent Port Assembly Service and Repair	0044
Figure 1. Vent Port Assembly.....	0044-2
Filler/Discharge Assembly Service and Repair	0045
Figure 1. Filler/Discharge Assembly.....	0045-2
Tank Drain Fitting Assembly Service and Repair.....	0046
Figure 1. Tank Drain.....	0046-1
Tank Envelope Service.....	0047
Figure 1. Tank Assembly.....	0047-1
Berm Liner Drain Fitting Assembly Service and Repair	0048
Figure 1. Berm Liner Drain Fitting Assembly.....	0048-1
Berm Liner Drain Hose Assembly, Bowl x Cam Service and Repair	0049
Figure 1. Berm Liner Drain Hose Assembly, Bowl x Cam	0049-1
Berm Liner Drain Hose Assembly, Cam x Cam Service and Repair	0050
Figure 1. Berm Liner Drain Hose Assembly, Cam x Cam	0050-2
Preparation for Storage and Shipment.....	0051
 Chapter 7 – Parts Information for Tank, Fabric, Collapsible, Fuel Storage 20,000 Gallon	
Introduction	0052
Table 1. SMR Code Explanation	0052-1
GROUP 00 Tank Assembly.....	0053
Figure 1. Tank Assembly.....	0053-2
GROUP 01 Filler/Discharge Hose Assembly	0054
Figure 2. Filler/Discharge Hose Assembly	0054-2
GROUP 02 Tank Drain Ball Valve Assembly	0055
Figure 3. Tank Drain Ball Valve Assembly	0055-2
GROUP 03 Tank Drain Hose Assembly, Bowl x Cam	0056
Figure 4. Tank Drain Hose Assembly, Bowl x Cam ..	0056-2

TABLE OF CONTENTS

	<u>Page No.</u>	<u>WP Sequence No.</u>
GROUP 03	Tank Drain Hose Assembly, Cam x Cam	0057
	Figure 5. Tank Drain Hose Assembly, Cam x Cam ..	0057-2
GROUP 04	Vent Port Assembly.....	0058
	Figure 6. Vent Port Assembly.....	0058-2
GROUP 05	Filler/Discharge Assembly.....	0059
	Figure 7. Filler/Discharge Assembly.....	0059-2
GROUP 06	Tank Drain Fitting Assembly	0060
	Figure 8. Tank Drain Fitting Assembly	0060-2
GROUP 07	Tank Envelope	0061
	Figure 9. Tank Envelope	0061-2
GROUP 08	Berm Liner Assembly	0062
	Figure 10. Berm Liner Assembly	0062-2
GROUP 0801	Berm Liner Drain Fitting Assembly.....	0063
	Figure 11. Berm Liner Drain Fitting Assembly.....	0063-2
GROUP 0802	Berm Liner Drain Ball Valve Assembly	0064
	Figure 12. Berm Liner Drain Ball Valve Assembly	0064-2
GROUP 0803	Berm Liner Drain Hose Assembly, Bowl x Cam	0065
	Figure 13. Berm Liner Drain Hose Assembly, Bowl x Cam	0065-2
GROUP 0804	Berm Liner Drain Hose Assembly, Cam x Cam.....	0066
	Figure 14. Berm Liner Drain Hose Assembly, Cam x Cam	0066-2
GROUP 0805	Berm Liner.....	0067
	Figure 15. Berm Liner.....	0067-2
GROUP 09	Emergency Repair Kit	0068
	Figure 16. Emergency Repair Kit	0068-2
	National Stock Number Index.....	0069
	Part Number Index	0070
Chapter 8 – Supporting Information for Tank, Fabric, Collapsible, Fuel Storage 20,000 Gallon		
	References	0071
	Maintenance Allocation Chart (MAC) Introduction	0072
	Maintenance Allocation Chart (MAC)	0073

TABLE OF CONTENTS

	<u>Page No .</u>	<u>WP Sequence No.</u>
Table 1. Maintenance Allocation Chart (MAC).....	0073-1	
Table 2. Tools and Test Equipment Requirements for Tank Assembly.....	0073-3	
Table 3. Remarks for Tank Assembly	0073-3	
Components of End Item (COEI) and Basic Issue Item (BII) Lists.....		0074
Table 1. Components of End Item (COEI)	0074-2	
Table 2. On Board Spares.....	0074-6	
Table 3. Basic Issue Items (BII) List.....	0074-7	
Expendable and Durable Items List (EDIL)		0075
Table 1. Expendable and Durable Items List (EDIL)	0075-1	
Mandatory Replacement Parts List (MRPL).....		0076
Table 1. Mandatory Replacement Parts List (MRPL)	0076-1	
DA Form 2028		
Authentication Page		
Metric and PIN Page		

HOW TO USE THIS MANUAL

This manual contains certain features to improve the convenience of using this manual and increase the user's efficiency. These features include:

a. Accessing Information

This manual contains a Front Cover, Warning Summary, List of Effected Pages, Title Block Page, Table of Contents, Chapters 1 through 8, and an Alphabetical Index. Information is accessed by referring to Table of Contents, located in the front of this manual, or by looking in the Alphabetical Index, located in the back of the manual.

b. Illustrations

Various methods are used to locate, operate and repair or replace components. Locator illustrations in Controls and Indicator tables, PMCS tables, exploded views and cut-away diagrams make the information in the manual easier to understand and follow.

c. Using This Manual

When using this manual, read and understand the entire maintenance action before performing the task. Also, read and understand all warnings, cautions and notes, as well as general safety precautions that apply to the task to be performed. The warning summary will inform personnel of hazards associated with the equipment to be operated, maintained or repaired. However, the summary is not all-inclusive and personnel should be aware at all times of hazardous conditions that may arise.

Prior to starting the procedures in this manual, read the initial setup requirements located directly above each procedure. The information is given to ensure all materials, expendables, tools and any other equipment necessary are readily available for use. The initial setup will be accomplished prior to starting the actual steps of each operator or maintenance procedure.

LOCATING MAJOR COMPONENTS

Obtain the manual for the system to be operated, maintained or repaired. Turn to the Table of Contents located in the front of this manual. Find Chapter 1, *General Information, Equipment Description and Theory of Operation*. Under the chapter title you will find the work package titled *Equipment Description and Data* which contains *Location and Description of Major Components*. Turn to the work package indicated. The indicated work package will provide an illustration and brief description of each major components and its location.

OPERATING PROCEDURES

The Table of Contents may be used to locate operating procedures within this manual. To locate a particular operating procedure, open the manual to the Table of Contents located in the front of this manual. Locate Chapter 2, *Operator Instructions*. Under this section, locate the work package for the component you intend to operate. To the right of the operating procedure will be a work package number. Turn to the work package indicated and follow the steps to perform the procedure. The procedures indicate how to set up and operate the equipment. Follow the procedures indicated to complete the task.

HOW TO USE THIS MANUAL – CONTINUED

At the top of the task, you will find a section entitled *INITIAL SETUP*. There are six basic headings listed under *INITIAL SETUP*.

Test Equipment: Lists all test equipment (standard or special) required to troubleshoot, test and inspect the equipment covered in this manual. The test equipment is identified with an item number and work package number from the *Maintenance Allocation Chart*, located in Chapter 8, *Supporting Information*.

Tools and Special Tools: Lists all tools (standard or special) required to perform the task. Tools are identified with an item number and work package number from the *Maintenance Allocation Chart*, located in Chapter 8, *Supporting Information*.

Materials/Parts: Lists all parts or materials necessary to perform the task. Expendable and durables are identified with an item number from the applicable work package located in Chapter 8, *Supporting Information*.

Personnel Required: Lists all personnel necessary to perform the task.

Equipment Condition: Notes the conditions that must exist before starting the task. The equipment condition will also include any prerequisite maintenance tasks to be performed with reference to the work package number or the Technical Manual (TM) number.

References: Include any other manuals necessary to complete the task. When there are no references listed, all steps necessary to complete the task are contained within this manual. A listing of reference materials is contained in the applicable work package in Chapter 8, *Supporting Information*.

TROUBLESHOOTING PROCEDURES

The Table of Contents may be used to locate sections within this manual. To locate a particular troubleshooting procedure, open the manual to the Table of Contents located in the front of this manual. Locate Chapter 3 or Chapter 5 *Troubleshooting Procedures (Operator or Field Maintenance)*. Under this section, find a work package titled *Master Malfunction/Symptom Index*. Turn to the work package indicated, which lists all troubleshooting procedures. Review the list until you find the appropriate work package for the problem you intend to solve. To the right of the procedure will be a work package number. Turn to the work package indicated and follow the steps to complete the troubleshooting procedure. Each procedure lists the malfunction, symptom and the corrective action for the problem at hand. The corrective action will indicate which maintenance procedure to refer to alleviate the symptom or what level of maintenance is capable of repairing the problem. Follow the procedures indicated to complete the task. At the top of the task, you will find a section entitled *INITIAL SETUP*. There are six basic headings listed under *INITIAL SETUP*.

Test Equipment: Lists all test equipment (standard or special) required to troubleshoot, test and inspect the equipment covered in this manual. The test equipment is identified with an item number and work package number from Table 3 of the *Maintenance Allocation Chart*, *Tools and Test Equipment*, located in Chapter 8, *Supporting Information*.

Tools: Lists all tools (standard or special) required to perform the task. Tools are identified with an item number and work package number from the *Maintenance Allocation Chart*, located in Chapter 8, *Supporting Information*.

Materials/Parts: Lists all mandatory replacement parts, expendable and durables necessary to perform the task. Expendable and durables and mandatory replacement parts are identified with an item number from the applicable work package located in Chapter 8, *Supporting Information*.

Personnel Required: Lists all personnel necessary to perform the task.

Equipment Condition: Notes the conditions that must exist before starting the task. The equipment condition will also include any prerequisite maintenance tasks to be performed with reference to the work package number or the TM number.

HOW TO USE THIS MANUAL – CONTINUED

References: Include any other manuals necessary to complete the task. When there are no references listed, all steps necessary to complete the task are contained within this manual. A listing of reference materials is contained in the work package entitled *References* in Chapter 8, *Supporting Information*.

MAINTENANCE INSTRUCTIONS

To locate a maintenance procedure, open the manual to the Table of Contents located in the front of this manual. Locate the chapter, which pertains to your level of maintenance; Chapter 4 for *Operator Maintenance Instructions*, or Chapter 6 for *Field Maintenance Instructions*. Look down the list and find the maintenance procedure to be accomplished. On the right side of the maintenance procedure will be a work package number. Turn to the work package indicated. Before beginning the maintenance task, look through the procedure to familiarize yourself with the entire maintenance procedure. At the top of the task you will have a section called INITIAL SETUP. There are six basic headings listed under INITIAL SETUP.

Test Equipment: Lists all test equipment (standard or special) required to troubleshoot, test and inspect the equipment covered in this manual. The test equipment is identified with an item number and work package number from Table 2 of the Maintenance Allocation Chart, *Tools and Test Equipment*, located in Chapter 8, *Supporting Information*.

Tools: Lists all tools (standard or special) required to perform the task. Tools are identified with an item number and work package number from Table 2 of the Maintenance Allocation Chart, *Tools and Test Equipment*, located in Chapter 8, *Supporting Information*.

Materials/Parts: Lists all mandatory replacement parts, expendable and durables necessary to perform the task. Expendable and durables and mandatory replacement parts are identified with an item number from the applicable work package located in Chapter 8, *Supporting Information*.

Personnel Required: Lists all personnel necessary to perform the task.

Equipment Condition: Notes the conditions that must exist before starting the task. The equipment condition will also include any prerequisite maintenance tasks to be performed with reference to the work package number or the TM number.

References: Include any other manuals necessary to complete the task. When there are no references listed, all steps necessary to complete the task are contained within this manual. A listing of reference materials is contained in the work package entitled *References* in Chapter 8, *Supporting Information*.

REPAIR PARTS AND SPECIAL TOOLS LIST

Refer to Chapter 8, *Supporting Information* when requisitioning parts, special tools and equipment.

Identify the mandatory repair parts required to perform The task listed at the top of the work package in the INITIAL SETUP. Using the reference provided, refer to the *Mandatory Replacement Parts List* work package in Chapter 8, *Supporting Information*. Using that part number, refer to the *Part Number Index* work package in TM 10-4930-365-13&P. Look up the part number in the part number column and identify the figure and item number where the part is located. Turn to the figure and locate the item number listed. Verify that the item is correct.

CHAPTER 1

**GENERAL INFORMATION, EQUIPMENT DESCRIPTION AND
THEORY OF OPERATION
FOR
TANK, FABRIC, COLLAPSIBLE, FUEL STORAGE,
20,000 GALLON**

**OPERATOR AND FIELD MAINTENANCE
TANK, FABRIC, COLLAPSIBLE, FUEL STORAGE, 20,000 GALLON
GENERAL INFORMATION**

SCOPE

This technical manual contains instructions for operation, checks, adjustments, and corrective maintenance for the 20,000 Gallon Fuel Storage Collapsible Fabric Tank. The system provides a portable fuel tank which is used to support and improve the operational readiness of Army units.

Type of Manual: Operator and Field Level Maintenance, Including Repair Parts and Special Tools List.

Model Number and Equipment Name: MPC-F-20K-AA, Tank, Fabric, Collapsible, Fuel Storage, 20,000 Gallon.

Purpose of Equipment: The Tank Envelope is a container designed to store a variety of petroleum products as part of a bulk fuel terminal. Fuel is available for use in a rapid response deployment operation.

MAINTENANCE FORMS, RECORDS AND REPORTS

Department of the Army forms and procedures used for equipment maintenance will be those prescribed by DA PAM 750-8, The Army Maintenance Management System (TAMMS) Users Manual.

REPORTING EQUIPMENT IMPROVEMENT RECOMMENDATIONS (EIR)

If your Tank Assembly needs improvement, send us an EIR. You, the user, are the only one who can tell us what you don't like about your equipment. Let us know why you don't like the design or performance. (E-Mail: TACOM-TECH-PUBS@conus.army.mil) We will send you a reply. The preferred method for submitting Quality Deficiency Reports (QDRs) is through the Army Electronic Product Support (AEPS) Web site under the Electronic Deficiency Reporting System (EDRS). The Web address is: <https://aeps.ria.army.mil>. If the above method is not available to you, put it on an SF 368 (Product Quality Deficiency Report) and mail it to us at: Department of the Army, U.S. Army Tank-automotive and Armaments Command, AMSRD-TAR-E, PDQR MS 268, 6501 E. 11 Mile Road, Warren, MI 38397-5000.

HAND RECEIPT (HR) MANUALS

There is no hand receipt manual for the Tank Assembly.

CORROSION PREVENTION AND CONTROL (CPC)

Corrosion prevention and control of Army materiel is a continuing concern. It is important that any corrosion problems with this item be reported so that the problem can be corrected and improvements can be made to prevent the problem in future items. While corrosion is typically associated with rusting of metals, it can also include deterioration of other materials, such as rubber and plastic. Any unusual cracking, softening, swelling, or breaking of the materials may be a corrosion problem.

If a corrosion problem is identified, it can be reported using Standard Form 368, Product Quality Deficiency Report. Use of key words such as "rust," "deterioration," "corrosion," or "cracking" will ensure that the information is identified as a CPC problem. The form should be submitted to the address specified in DA Pam 750-8.

DESTRUCTION OF ARMY MATERIEL TO PREVENT ENEMY USE

Command decisions, according to tactical situations, will determine when destruction of the Tank Assembly will be accomplished. A destruction plan will be prepared by the using organization, unless higher authority has prepared one. For general destruction procedures for this equipment, refer to TM 750-244-6, Procedures for Destruction of Tank-Automotive Equipment to Prevent Enemy Use.

PREPARATION PROCEDURES FOR STORAGE OR SHIPMENT

Army users refer to work package 0051.

NOMENCLATURE CROSS-REFERENCE LIST

<u>Common Name</u>	<u>Official Nomenclature</u>
Berm Liner Drain Valve	Ball Valve, 2 in. (5.08 cm)
Chain	Chain, Weldless
Compression Plate	Plate, Closure, Compression
Coupling Half	Coupling Half, Quick Disconnect
Discharge Elbow	Elbow, Quick Disconnect, Female x Male, 4-in (10.16 cm)
Drain Hose	Fuel Hose 20 ft (609.6 cm) x 2 in. (5.08 cm)
Dust Cap	Cap, Quick Disconnect
Dust Plug	Plug, Quick Disconnect
Female Coupling	Coupling Half, Quick Disconnect
Filler Elbow	Elbow, Quick Disconnect, Female x Female, 4-in (10.16 cm)
Flanged Adapter	Coupling Half, Quick Disconnect
Gasket	Gasket-Buna-N, 1/8 in. (0.3175 cm)
Male Coupling	Coupling Half, Quick Disconnect
Mechanical Patch	Patch, Mechanical, Flexible Surface
Nut	Nut, Plain, Hexagon
Screw	Screw, Cap, Hexagon Head
Tank Assembly	Tank, Fabric, Collapsible
Tank Envelope	Tank, Fabric, Collaps 20K Gallon, Petroleum
Vent Cap	Vent Cap, Passive
Vent Pipe	Pipe, Aluminum, 2 in. x 10 (5.08 x cm x 25.4 cm)
Washer	Washer, Flat

LIST OF ABBREVIATIONS/ACRONYMS

Abbreviation/Acronym	Name
AEPS	Army Electronic Product Support
AR	Army Regulation
BII	Basic Issue Items
C	Celsius
CAGEC	Commercial and Government Entity Code
CBRN	Chemical, Biological, Radiological, and Nuclear
cm	Centimeter

LIST OF ABBREVIATIONS/ACRONYMS – CONTINUED

Abbreviation/Acronym	Name
COEI	Components of End Item
CPC	Corrosion Prevention and Control
CTA	Common Table of Allowances
DA	Department of the Army
EDRS	Electronic Deficiency Reporting System
EIR	Equipment Improvement Recommendations
ESC	Equipment Serviceable Criteria
F	Fahrenheit
FGC	Functional Group Code
FM	Field Manual
ft	Foot
ft•lb	Foot-pound
gal	Gallon
GPM	Gallons per Minute
HR	Hand Receipt
Illus	Illustration
in.	Inch
in-lb	Inch-pound
JTA	Joint Table of Allowances
kg	Kilogram
L	Liter
LPM	Liters per Minute
lb	Pound
MAC	Maintenance Allocation Chart
m	Meter
MOPP	Mission Oriented Protective Posture
MTOE	Modified Table of Organization and Equipment
MWO	Modification Work Order
NBC	Nuclear, Biological and Chemical
NCOIC	Non-Commissioned Officer in Charge
N•m	Newton-meter
NSN	National Stock Number
OIC	Officer in Charge
PMCS	Preventive Maintenance Checks and Services
PN	Part Number
QDR	Quality Deficiency Report
Qty	Quantity
RPSTL	Repair Parts and Special Tools List
RQR	Required
SMR	Source Maintenance and Recoverability
TAMMS	The Army Maintenance Management System
TDA	Table of Distribution and Allowances
TM	Technical Manual
TMDE	Test, Measurement and Diagnostic Equipment
TOE	Table of Organization and Equipment
U/M	Unit of Measure
WCA	Warranty Claim Action

QUALITY OF MATERIAL

Material used for replacement, repair or modification must meet the requirements of this manual.

SAFETY, CARE AND HANDLING

The Tank Assembly may be used to store various fuels. It must be assumed that residual fuel and fuel vapors are present in the Tank Assembly at all times, even after draining or purging. Therefore, the equipment must always be handled as is full of fuel. One or more fully charged fire extinguishers must be present at all times.

SUPPORTING INFORMATION FOR REPAIR PARTS, SPECIAL TOOLS, TMDE, AND SUPPORT EQUIPMENT

Fuels are dangerous under all conditions. Always observe fuel handling safety precautions. For authorized common tools and equipment, refer to the Modified Table of Organization and Equipment (MTOE), CTA 50-970, Expendable/Durable Items (Except: Medical, Class V, Repair Parts, and Heraldic Items), CTA 50-909, Field and Garrison Furnishings and Equipment or CTA 8-100, Army Medical Department Expendable/Durable Items, as applicable to your unit.

END OF WORK PACKAGE

**OPERATOR AND FIELD MAINTENANCE
TANK, FABRIC, COLLAPSIBLE, FUEL STORAGE, 20,000 GALLON
EQUIPMENT DESCRIPTION AND DATA**

EQUIPMENT CHARACTERISTICS, CAPABILITIES AND FEATURES

GENERAL

This section lists major components, controls, and indicators, and describes the functions of the Tank Assembly.

DESCRIPTION AND USE OF MAJOR COMPONENTS

Description and use of major components, including controls and indicators, are contained in Table 1.

LOCATION AND DESCRIPTION OF MAJOR COMPONENTS

This section lists major components and describes the functions of the Tank Assembly. Description and use of major components are contained in Table 1.

NOTE

Connecting valves are not issued with the 20,000 Gallon Fuel Storage Collapsible Fabric Tank Assembly, but are required to safely operate and perform storage and distribution missions. Connecting valves must be obtained from the supporting fuel source host system.

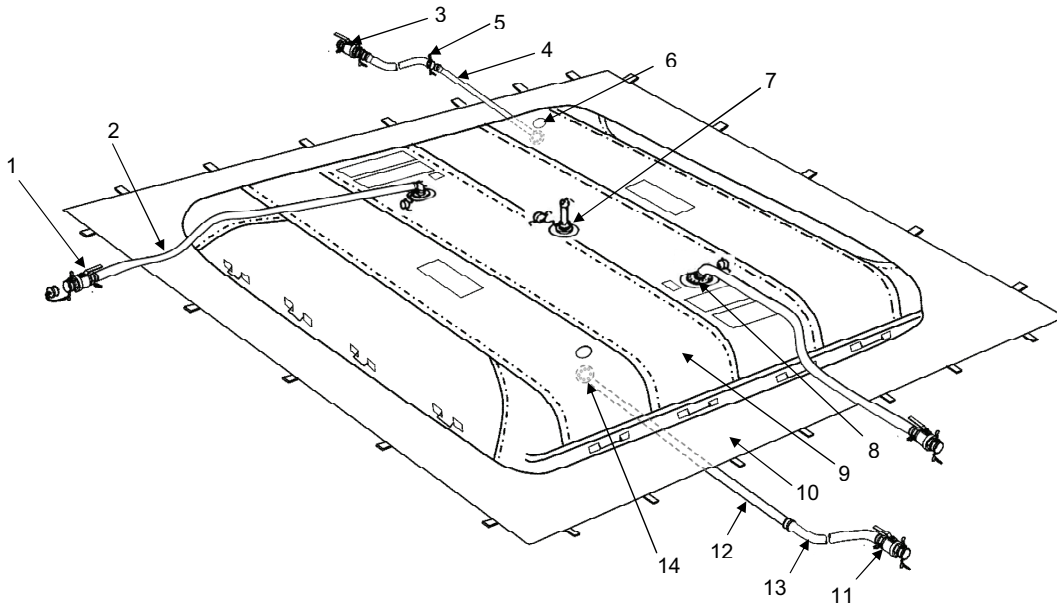

Figure 1. Tank Assembly.

LOCATION AND DESCRIPTION OF MAJOR COMPONENTS – CONTINUED

Table 1. Major Components.

KEY	DESCRIPTION	FUNCTION
1	Shutoff valve from fuel source host system	Allows fuel to flow to and from the Tank Assembly. The shutoff valve from fuel source host system is normally closed when the Tank Envelope is not being filled or drained.
2	Filler/Discharge Hose Assembly	Allows Tank Envelope to be filled and drained. Filler/Discharge Hose Assembly is comprised of a 4-in. (10.16-cm) x 10-ft (3.05-m) section of hose that can be attached to Filler/Discharge Valve.
3	Tank Drain Ball Valve Assembly	Allows fuel and sludge to drain from Tank Envelope. Drain Valve is normally closed when Tank Envelope is not being drained or replaced.
4	Tank Drain Hose Assembly, Bowl x Cam	Allows fuel and sludge to drain from the Tank Envelope.
5	Tank Drain Hose Assembly, Cam x Cam	Allows fuel and sludge to drain from the Tank Envelope.
6	Tank Drain Fitting Assemblies	Allow Drain Hose Assembly to be connected directly to Tank Envelope. Drain Fitting Assemblies are mounted on underside of Tank Envelope at each end.
7	Vent Port Assembly	Relieves fuel vapor pressure from inside the Tank Envelope.
8	Filler/Discharge Assemblies	Provide the means to both fill and remove fuel from Tank Envelope. Allow Filler/Discharge Assemblies to be connected to Tank Envelope. Direct flow of fuel into and out of Tank Envelope through Filler/Discharge Assemblies. Can be accessed by removing Dust Caps. In two locations at opposite ends of Tank Envelope.
9	Tank Envelope	Collapsible, elastomer-coated, nylon fabric fuel tank in 20,000 gallon capacity. Used for fuel storage.
10	Berm Liner	Used for secondary containment if Tank Envelope fails.
11	Berm Liner Drain Ball Valve Assembly	Allows fuel and sludge to drain from Berm Liner.
12	Berm Liner Drain Hose Bowl x Cam	Allows fuel and sludge to drain from Berm Liner.
13	Berm Liner Drain Hose Cam x Cam	Extends the distance of the Berm Liner draining capability.
14	Berm Liner Drain Fitting Assemblies	Allows Drain Hose Assembly to be connected directly to Berm Liner. Drain Fitting Assemblies are mounted on underside of Berm Liner at each end.
	Emergency Repair Kit (Not Shown)	Contains items needed to perform temporary repairs of cuts and punctures to Tank Envelope.

EQUIPMENT DATA

Table 2 provides data pertaining to the operation and mechanical characteristics of components of the Tank Assembly.

Table 2. Tank Assembly Specifications.

ITEM CHARACTERISTIC/SPECIFICATION	DESCRIPTION
Storage Capacity	20,000 gal (75,708 L)
Operating Temperature (Ambient)	
Low	-25°F (-32°C)
High	+140°F (+60°C)
Storage Temperature (Ambient)	
Low	-25°F (-32°C)
High	+160°F (+71°C)
Dimensions, Outside (Packaged):	
Height	45 in. (1.14 m)
Width	60 in. (1.52 m)
Length	96 in. (2.44 m)
Weight (Crated, Including Berm Liner and Accessories)	1,991 lb (903.10 kg)
Dimensions (Filled)	
Height	5 ft 11 in. (1.80 m) on initial fill 5 ft 7-1/2 in. (1.71 m) after 24 hours
Length	27 ft 1 in. (8.26 m)
Width	23 ft 7 in. (7.19 m)
Dimensions (Unfolded)	
Length	28 ft ±12 in. (8.53 m ±30.48 cm)
Width	25 ft ±12 in. (7.62 m ±30.48 cm)
Berm Liner Assembly	
Part Number	MPC-20K-BL-6565
Length (Unfolded)	65 ft (19.81 m)
Width (Unfolded)	65 ft (19.81 m)
Weight	574 lb (260.36 kg)

EQUIPMENT DATA – CONTINUED

Table 3 provides data pertaining to Tank Assembly strapping after 24 hours filled. Upon initial fill, the tank may be filled to 5 ft 11 in. After 24 hours, the tank will stretch and settle to approximately 5 ft 7-1/2 in. This strapping chart is used to convert height measurements into gallons.

NOTE

These strapping charts have been developed for #2 diesel fuel at 60°F. Tank volumes are approximate ($\pm 5\%$).

Variables such as fabric stretch over time, grade or slope, where deployed, temperature, and irregularities of earthen surface will affect accuracy.

Dimensions shown are $\pm 1/2$ " except as noted.

Table 3. Strapping Chart – After 24 Hours Filled.

TANK HEIGHT		TOTAL GALLONS OF FUEL IN TANK	GALLONS PER 1/8" TO NEXT MEASUREMENT	TANK HEIGHT		TOTAL GALLONS OF FUEL IN TANK	GALLONS PER 1/8" TO NEXT MEASUREMENT
FT	IN			FT	IN		
0	1	360	45	1	10	7,477	40
0	2	718	45	1	11	7,795	39
0	3	1,074	44	2	0	8,111	39
0	4	1,429	44	2	1	8,425	39
0	5	1,781	44	2	2	8,737	39
0	6	2,131	44	2	3	9,048	39
0	7	2,480	43	2	4	9,356	38
0	8	2,826	43	2	5	9,662	38
0	9	3,171	43	2	6	9,967	38
0	10	3,514	43	2	7	10,269	38
0	11	3,855	42	2	8	10,570	37
1	0	4,194	42	2	9	10,868	37
1	1	4,531	42	2	10	11,165	37
1	2	4,866	42	2	11	11,460	37
1	3	5,199	41	3	0	11,753	36
1	4	5,530	41	3	1	12,044	36
1	5	5,859	41	3	2	12,333	36
1	6	6,187	41	3	3	12,620	36
1	7	6,512	40	3	4	12,906	35
1	8	6,836	40	3	5	13,189	35

EQUIPMENT DATA – CONTINUED

Table 3. Strapping Chart – After 24 Hours Filled – Continued.

TANK HEIGHT		TOTAL GALLONS OF FUEL IN TANK	GALLONS PER 1/8" TO NEXT MEASUREMENT
FT	IN		
1	9	7,158	40
3	7	13,750	35
3	8	14,028	34
3	9	14,303	34
3	10	14,577	34
3	11	14,849	34
4	0	15,119	34
4	1	15,387	33
4	2	15,653	33
4	3	15,917	33
4	4	16,180	33
4	5	16,440	32
4	6	16,698	32
4	7	16,955	32

TANK HEIGHT		TOTAL GALLONS OF FUEL IN TANK	GALLONS PER 1/8" TO NEXT MEASUREMENT
FT	IN		
3	6	13,470	35
4	8	17,210	32
4	9	17,462	31
4	10	17,713	31
4	11	17,962	31
5	0	18,209	31
5	1	18,454	30
5	2	18,697	30
5	3	18,938	30
5	4	19,178	30
5	5	19,415	29
5	6	19,650	29
5	7	19,884	29
5	7.5	20,000	N/A

END OF TASK

END OF WORK PACKAGE

**OPERATOR AND FIELD MAINTENANCE
TANK, FABRIC, COLLAPSIBLE, FUEL STORAGE, 20,000 GALLON
THEORY OF OPERATION**

INTRODUCTION

Connecting a hose from a fuel truck or other fuel source to the Filler/Discharge Hose Assembly fills the Tank Envelope. This assembly is attached to the shutoff valve from the fuel source host system, which is connected to the Filler/Discharge Assembly.

The Filler/Discharge Hose Assembly and shutoff valve from the fuel source host system controls the flow of fuel from the Tank Envelope. Water, sludge, and residual fuel are drained through the Drain Hose Assembly at the bottom of the Tank Envelope. The fuels are extremely hazardous, and all safety procedures must be strictly followed.

The Vent Port Assembly relieves fuel vapor pressure from inside the Tank Envelope, and also contains a Flame Arrestor to suppress flame ignition.

END OF WORK PACKAGE

CHAPTER 2

OPERATOR INSTRUCTIONS
FOR
TANK, FABRIC, COLLAPSIBLE, FUEL STORAGE,
20,000 GALLON

OPERATOR INSTRUCTIONS
DESCRIPTION AND USE OF OPERATOR CONTROLS AND INDICATORS

INTRODUCTION

Refer to Figure 1 for identification of major components, including controls and indicators. Table 1 describes the function of controls and indicators.

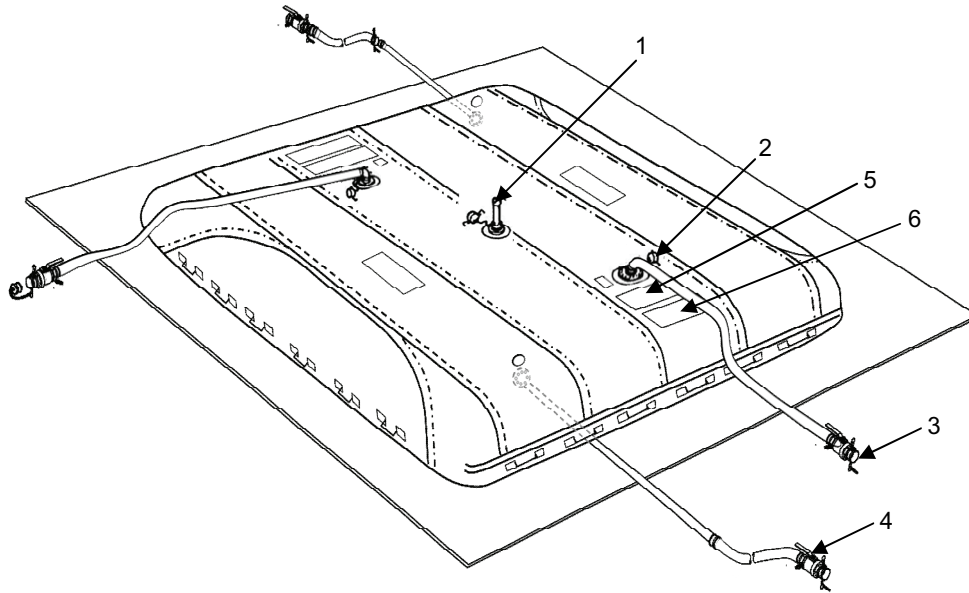

Figure 1. Controls and Indicators.

Table 1. Controls and Indicators.

KEY	CONTROL/INDICATOR	FUNCTION
1	Vent Port Assembly	Allows release of fuel vapors into atmosphere to relieve pressure within Tank Envelope.
2	Filler/Discharge Assembly	Allows fuel to flow to and from Tank Assembly.
3	Shutoff valve from fuel source host system	Controls flow of fuel to and from Tank Assembly. Shutoff valve from fuel source host system is normally closed when Tank Envelope is not being filled or fuel is not being discharged from Tank Envelope.
4	Tank Drain Ball Valve Assembly	Allows fuel and sludge to drain from Tank Envelope. Tank Drain Ball Valve Assembly is normally closed when Tank Envelope is not being drained or replaced.
5	Identification Stenciling	Gives Tank Envelope identification, NSN, manufacturer, date of manufacture, etc.
6	Caution Stenciling	Gives caution notice, Tank Envelope capacity, and maximum safe height.

END OF TASK

END OF WORK PACKAGE

**OPERATOR INSTRUCTIONS
OPERATION UNDER USUAL CONDITIONS**

INITIAL SETUP:

Personnel Required

Petroleum Supply Specialist 92F (2)

References

WP 0006

WP 0049

Materials/Parts

Tape, pressure sensitive adhesive (WP 0075, Item 10)

ASSEMBLY AND PREPARATION FOR USE

Unpack Tank Assembly, Berm Liner Assembly, and Components

1. Position shipping container near designated berm.

NOTE

Items inside shipping container are listed sequentially from top of shipping container to bottom.

2. Verify contents of shipping container by reviewing Packing List. (See Figure 1 and Tables 1 and 2.)

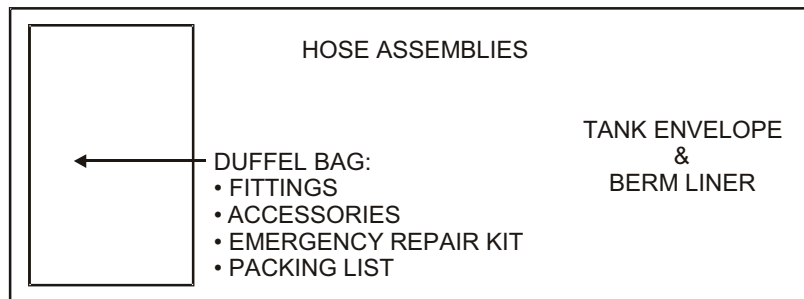

Figure 1. Shipping Container Layout.

ASSEMBLY AND PREPARATION FOR USE – CONTINUED**Table 1. Tank Assembly Components in Shipping Container.**

<u>ITEM</u>	<u>QUANTITY</u>
Filler/Discharge Hose Assembly	2 each
Tank Drain Ball Valve Assembly	1 each
Tank Drain Hose	1 each
Tank Drain Hose Assembly, Bowl x Cam	1 each
Tank Envelope	1 each
Duffel Bag, containing accessories and Emergency Repair Kit	1 each
Lifting Slings	2 each

Table 2. Berm Liner Components in Shipping Container.

<u>ITEM</u>	<u>QUANTITY</u>
Berm Liner Drain Ball Valve Assembly	1 each
Berm Liner Drain Hose Assembly	1 each
Berm Liner Drain Hose Assembly, Bowl x Cam	1 each
Berm Liner	1 each
Lifting Slings	2 each

- Carefully open shipping container by removing fasteners from container lid. Remove container lid, hoses, and duffel bag.

WARNING

A suitable lifting device for Tank Assembly components must have a 2,000 lb/908.00 kg or greater capacity. Failure to heed this warning can cause injury or death to personnel.

- Locate Lifting Slings around Tank Envelope. Carefully lift from container using a suitable lifting device (2,000 lb/908.00 kg capacity) inserted through loops of Lifting Slings.
- Lift Tank Envelope from container and place near designated berm.
- Locate Lifting Slings around Berm Liner. Carefully lift from container using a suitable lifting device (2,000 lb/908.00 kg capacity) inserted through loops of Lifting Slings.
- Lift Berm Liner from container and place near designated berm.

Install Berm Liner Assembly, Tank Assembly, and Components**Berm Liner Assembly**

- Carefully position Berm Liner in center of berm.
- Unfold one-half of Berm Liner along length of berm, and unfold other half of Berm Liner in opposite direction.
- Grasp handles located along length of Berm Liner, and pull folded sides of Berm Liner over mound of berm in all directions.
- Fold liner back to access Berm Liner drain.

ASSEMBLY AND PREPARATION FOR USE – CONTINUED**NOTE**

Blind Flange Cover must be removed and Berm Liner Drain Hose Assembly, Bowl x Cam (Figure 2, Item 1), Berm Liner Drain Hose Assembly (Figure 2, Item 2), and Berm Liner Drain Valve (Figure 2, Item 3), must be assembled prior to Tank Assembly installation. Installation of Berm Liner Drain Hose Assembly, Bowl x Cam (Figure 2, Item 1) is performed by Field Maintenance (WP 0049).

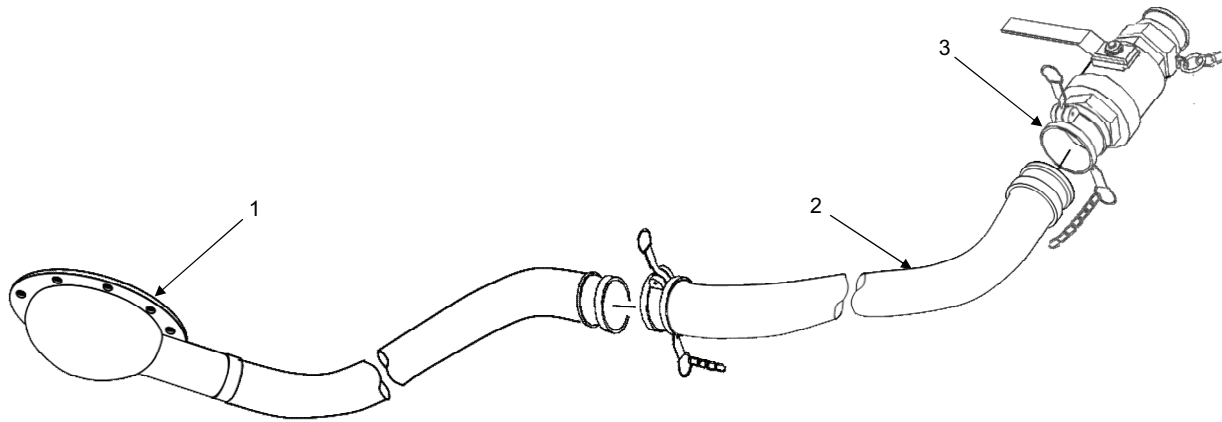

Figure 2. Berm Liner Drain Hose Assembly, Bowl x Cam, Drain Hose, and Drain Valve.

NOTE

Cam-lever arms must be pushed inward to lock and pulled outward to unlock female coupling of Berm Liner Drain Hose Assembly (Figure 2, Item 2).

5. Connect female coupling of Berm Liner Drain Hose Assembly (Figure 2, Item 2) to male coupling of Berm Liner Drain Hose Assembly, Bowl x Cam (Figure 2, Item 1).

NOTE

The berm mound is constructed with a drain culvert to allow for the draining of the berm through the Berm Liner Drain Hose Assembly, Bowl x Cam (Figure 2, Item 1).

6. Connect female coupling of Berm Liner Drain Valve (Figure 2, Item 3) to male coupling of Berm Liner Drain Hose Assembly (Figure 2, Item 2).
7. After installation of Berm Liner Drain Hose Assembly, Bowl x Cam (Figure 2, Item 1) and connection of Berm Liner Drain Hose Assembly (Figure 2, Item 2), insert the hoses through the berm mound culvert. Then, unfold and smooth out all creases and wrinkles in Berm Liner.

ASSEMBLY AND PREPARATION FOR USE – CONTINUED**Tank Assembly**

1. Position packaged Tank Envelope (Figure 3, Item 1) near designated berm.

CAUTION

Unfold Tank Envelope with care. Coated surfaces may stick together, and use of excessive force may pull coating from fabric. To avoid puncturing Tank Envelope, remove protruding nails and other objects before attempting to remove Tank Envelope from container.

2. Carefully open shipping container (Figure 1) by removing fasteners from container lid. Remove lid, Filler/Discharge Hose Assembly, Tank Drain Hose Assembly, Bowl x Cam, Tank Drain Hose, Vent Port Assembly, and Tank Drain Valve from around Tank Envelope.
3. Transport Tank Envelope to center of designated berm (Figure 3, Item 2). Position long side of Tank Envelope (Figure 3, Item 1) parallel with long side of berm (Figure 3, Item 2).

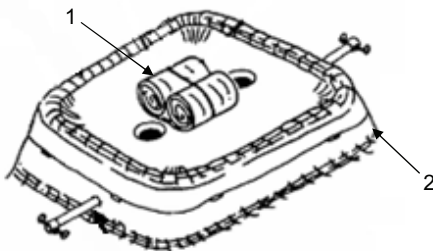

Figure 3. Position Tank Envelope.

4. Unroll one-half of Tank Envelope (Figure 4, Item 1) along length of berm (Figure 4, Item 2), and unroll other half of Tank Envelope (Figure 4, Item 1) in opposite direction along length of berm (Figure 4, Item 2).

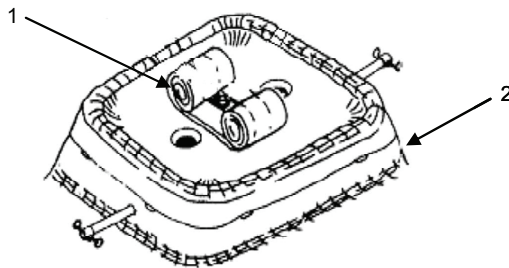

Figure 4. Unroll Tank Envelope.

NOTE

Emergency Repair Kit is packaged in duffel bag and should be placed in a secure storage area until needed.

ASSEMBLY AND PREPARATION FOR USE – CONTINUED

5. Grasp handles located along length of Tank Envelope (Figure 5, Item 1), and pull folded sides of Tank Envelope (Figure 5, Item 1) toward sides of berm (Figure 5, Item 2).

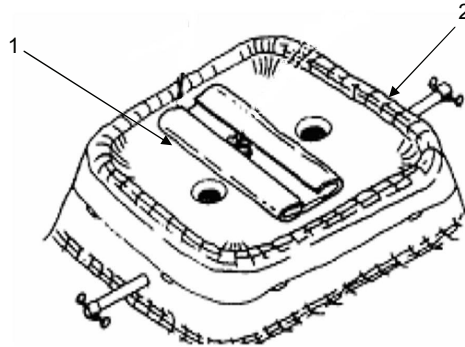

Figure 5. Unfold Tank Envelope.

6. Smooth out all creases and wrinkles in Tank Envelope (Figure 5, Item 1) fabric.
7. Remove ball valves, Filler/Discharge Elbows, Tank Drain Valve, and Vent Port Assembly from cushioning bags. Remove cushioning bags from ends of hoses. Save cushioning bags and packing material for reuse when Tank Assembly is put back into storage.

Installation of Tank Drain Hose Assembly, Bowl x Cam, Tank Drain Hose Assembly, and Tank Drain Valve

CAUTION

Prior to installing Tank Assembly, check all coupling gaskets and sealing surfaces to ensure they are in place and serviceable. Failure to comply could result in damage to equipment.

NOTE

Tank Drain Hose Assembly, Bowl x Cam (Figure 6, Item 1), Tank Drain Hose Assembly (Figure 6, Item 2), and Tank Drain Valve (Figure 6, Item 3), must be installed prior to introduction of fuel into Tank Assembly, and prior to installation of Tank Drain Hose Assembly (Figure 6, Item 2) and drain ball valve. Field Maintenance must install Tank Drain Hose Assembly, Bowl x Cam (Figure 6, Item 1).

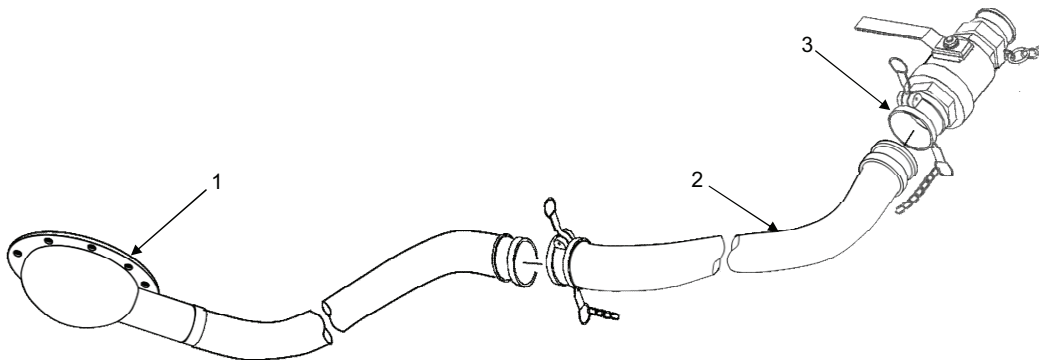

Figure 6. Tank Drain Hose Assembly, Bowl x Cam, Drain Hose, and Drain Valve.

ASSEMBLY AND PREPARATION FOR USE – CONTINUED**NOTE**

Cam-lever arms must be pushed inward to lock and pulled outward to unlock Female Coupling Half.

1. Connect female coupling of Tank Drain Hose Assembly (Figure 6, Item 2) to male coupling of Tank Drain Hose Assembly, Bowl x Cam (Figure 6, Item 1).
2. Connect female coupling of Drain Valve (Figure 6, Item 3) to male coupling of Tank Drain Hose Assembly (Figure 6, Item 2).

Installation of Vent Port Assembly

Figure 7. Dust Cap Removal.

1. Remove Dust Cap (Figure 7, Item 1) by pulling cam-lever arms (Figure 7, Item 2) outward, and lifting up on Dust Cap (Figure 7, Item 1).

ASSEMBLY AND PREPARATION FOR USE – CONTINUED

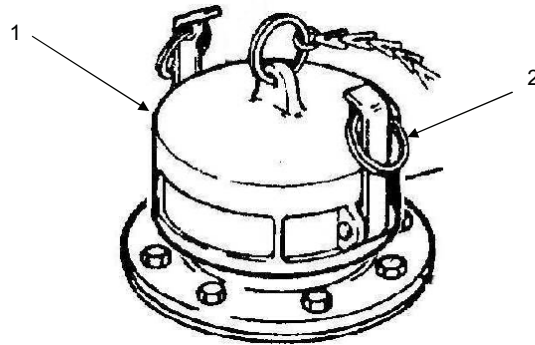
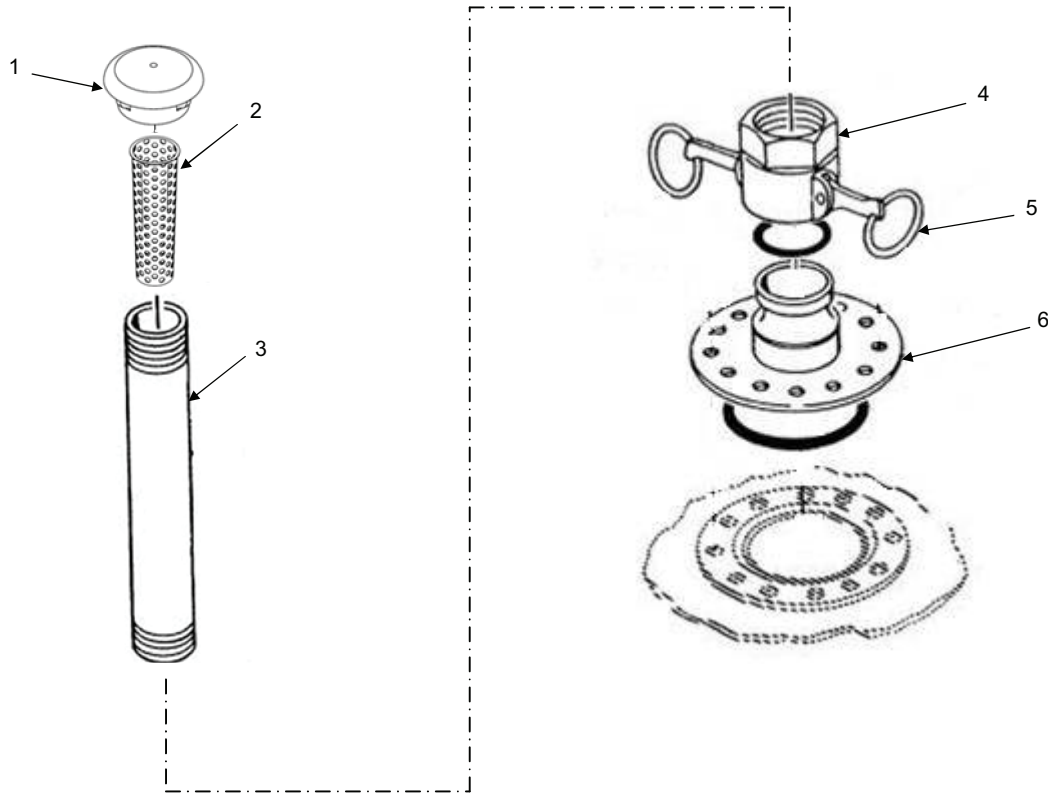

Figure 8. Vent Port Assembly.

NOTE

Vent Port and Coupling Half are pre-assembled.

2. Inspect Coupling Half (Figure 8, Item 4) and Vent Pipe (Figure 8, Item 3) for cleanliness.
3. Inspect Flame Arrestor (Figure 8, Item 2) and Vent Cap (Figure 8, Item 1) for debris.
4. Check that Flame Arrestor (Figure 8, Item 2) and Vent Cap (Figure 8, Item 1) are installed tightly on Vent Pipe (Figure 8, Item 3).
5. Connect Coupling Half (Figure 8, Item 4) to Flanged Adapter (Figure 8, Item 6), with cam-lever arms (Figure 8, Item 5) in outward position.
6. Press cam-lever arms (Figure 8, Item 5) upward and inward to lock Vent Port Assembly into operating position.

ASSEMBLY AND PREPARATION FOR USE – CONTINUED

Installation of Elbow Coupling

NOTE

Dust Cap is attached to Flanged Adapter to prevent it from being lost. Discharge end requires Discharge Elbow (female x male), and Filler end requires Filler Elbow (female x female).

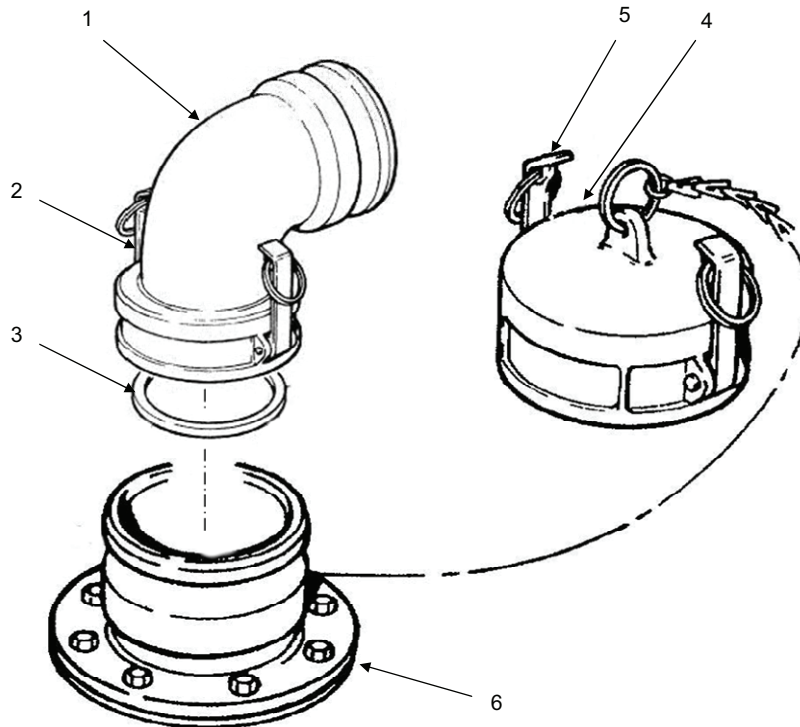

Figure 9. Filler/Discharge Elbow.

1. Inspect Filler/Discharge Elbow (Figure 9, Item 1) for cleanliness and proper seating of Gasket (Figure 9, Item 3).
2. Remove Dust Cap (Figure 9, Item 4) from Flanged Adapter (Figure 9, Item 6) by pulling cam-lever arms (Figure 9, Item 5) outward and lifting up on Dust Cap (Figure 9, Item 4).
3. Position female end of Filler/Discharge Elbow (Figure 9, Item 1) over Flanged Adapter (Figure 9, Item 4) with cam-lever arms (Figure 9, Item 2) in outward position.
4. Rotate Filler/Discharge Elbow (Figure 9, Item 1) so that open end points to nearest end of Tank Envelope.

ASSEMBLY AND PREPARATION FOR USE – CONTINUED**NOTE**

Cam-lever arms must be pushed inward to lock and pulled outward to unlock Filler/Discharge Elbow.

5. Lift cam-lever arms (Figure 9, Item 2) and lock Filler/Discharge Elbow (Figure 9, Item 1) in place.
6. Install Dust Cap (Figure 9, Item 4) on open end of Filler/Discharge Elbow (Figure 9, Item 1) and lock in place.

Installation of Filler/Discharge Hose, Filler/Discharge Elbow and Shutoff Valve from Fuel Source Host System**NOTE**

Cam-lever arms must be pushed inward to lock and pulled outward to unlock Female Coupling.

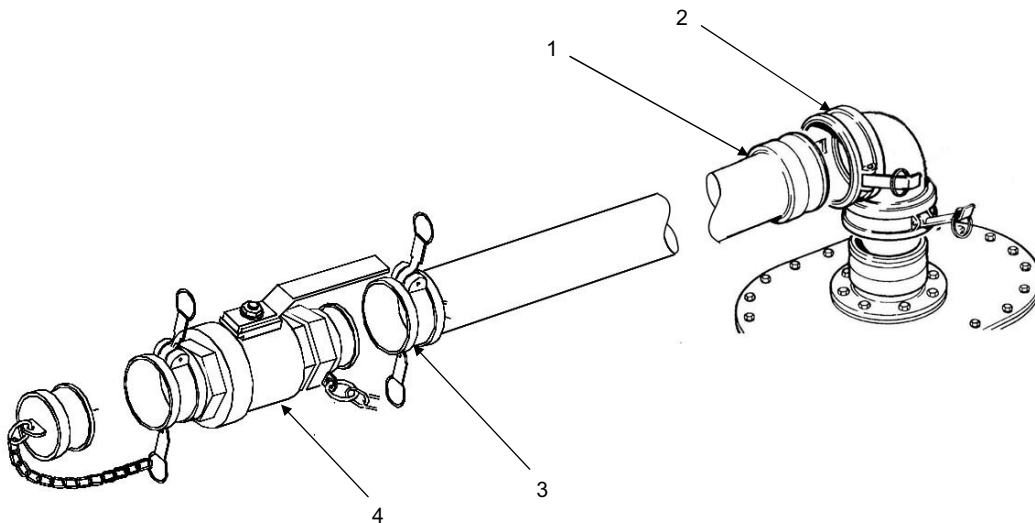

Figure 10. Filler/Discharge Hose Assembly and Shutoff Valve from Fuel Source Host System.

1. Remove Dust Cap (Figure 9, Item 4) from Filler/Discharge Elbow (Figure 10, Item 2).
2. Connect male coupling of Filler/Discharge Hose Assembly (Figure 10, Item 1) to Filler Elbow (Figure 10, Item 2).
3. Push Filler/Discharge Hose Assembly cam-lever arms (Figure 10, Item 3) into position to lock shutoff valve from fuel source host system (Figure 10, Item 4) in place.

END OF TASK

INITIAL ADJUSTMENTS AND ROUTINE CHECKS**NOTE**

If Tank Envelope is cut or punctured during any phase of operation, refer to WP 0006 for emergency repair procedures.

1. Position filled sandbag (Figure 11, Item 1) under Filler/Discharge Hose Assembly (Figure 11, Item 2) near Filler/Discharge Elbow (Figure 11, Item 3). This support will reduce stress on Tank Envelope fitting, Gasket in hose coupling, and Filler/Discharge Elbow (Figure 11, Item 3).
2. Position other sandbags (Figure 11, Item 4) or wood blocks on ground near hose connections so that a faulty or leaking connection is easier to detect.
3. Check Tank Drain Valve (Figure 11, Item 5) to verify it is closed.
4. Check Vent Port Assembly (Figure 11, Item 6) to verify connection.
5. Check shutoff valve from fuel source host system (Figure 11, Item 7) to verify it is closed.

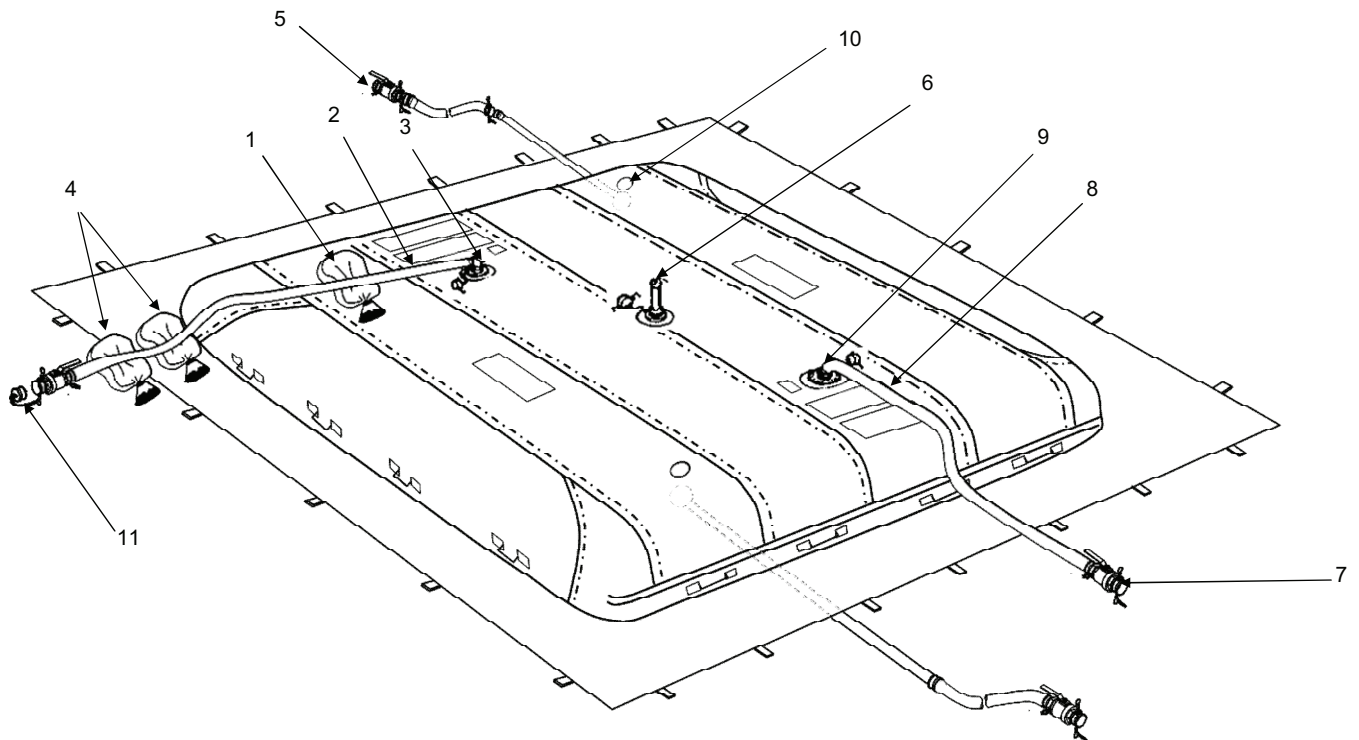

Figure 11. Elevated Connections.

END OF TASK

OPERATING PROCEDURES

Filling Tank Envelope

WARNING

Over-aged Tank Envelope can become weakened and rupture, thereby spilling flammable fuel on ground. Care must be taken to ensure that over-aged Tank Envelope is inspected for signs of deterioration. Tank Envelope showing signs of deterioration should be removed from operation. Failure to heed warning can cause injury or death to personnel.

CAUTION

Personnel operating Tank Envelope must periodically check dates on data plates to verify that Tank Envelope is safe for use. Shelf storage life is 12 years from date of manufacture. Tank Envelope showing signs of deterioration should not be placed in operation. Failure to heed caution could result in Tank Envelope rupture causing damage to and loss of government property.

1. After performing adjustments and routine checks, attach fuel source to shutoff valve from fuel source host system (Figure 11, Item 11).
2. Activate fuel source.
3. Open shutoff valve from fuel source host system (Figure 11, Item 11).

WARNING

Do not exceed maximum fill capacity. Tank Envelope will burst if it is overfilled, causing serious injury to personnel.

4. Close shutoff valve from fuel source host system (Figure 11, Item 11) when Tank Envelope is full.
5. Deactivate fuel source.
6. Disconnect fuel source from shutoff valve from fuel source host system (Figure 11, Item 11).

Draining Tank

1. Inspect Tank Envelope to verify it is set up correctly.
2. Attach an emptying source to shutoff valve from fuel source host system (Figure 11, Item 7).
3. Open shutoff valve from fuel source host system (Figure 11, Item 7).
4. Activate emptying source.
5. Close shutoff valve from fuel source host system (Figure 11, Item 7) when Tank Envelope is empty.
6. Deactivate emptying source.
7. Disconnect emptying source from shutoff valve from fuel source host system (Figure 11, Item 7).
8. Disconnect Filler/Discharge Hose Assembly (Figure 11, Item 8) from Filler/Discharge Elbow (Figure 11, Item 9).
9. Squeeze excess fuel from Tank Envelope by rolling ends of Tank Envelope towards Tank Drain Fitting (Figure 11, Item 10).
10. Open Tank Drain Valve (Figure 11, Item 5) to allow remaining fuel to drain from Tank Envelope.

OPERATING PROCEDURES – CONTINUED**WARNING**

Sludge that accumulates in bottom of Tank Envelope gives off toxic and explosive vapors. Inhaling these vapors can cause lead poisoning. When cleaning Tank Envelope, provide ample ventilation to carry off harmful fumes.

11. Clean Tank Envelope of residual sludge that accumulates at bottom of Tank Envelope and dispose of sludge in compliance with Environmental Protection Agency (EPA) and local regulations.

END OF TASK**PREPARATION FOR MOVEMENT****CAUTION**

Always handle Tank Envelope carefully. Components stored with Tank Envelope should be padded to avoid chafing during movement. Rough handling of Tank Envelope or components will result in damage.

1. Drain all fuel from Tank Envelope.
2. Remove Tank Drain Hose Assembly (Figure 11, Item 12) from Tank Drain Fitting (Figure 11, Item 13).
3. Remove Filler/Discharge Elbows (Figure 11, Item 9) from Tank Envelope.
4. Install Dust Caps, pushing in on cam-lever arms to lock Dust Caps in place.
5. Remove Vent Port Assembly (Figure 11, Item 6) from Flanged Adapter and install Dust Cap, pushing in on cam-lever arms to lock Dust Caps in place.
6. Brush away stones or debris clinging to Tank Envelope.

PREPARATION FOR MOVEMENT – CONTINUED**Packing and Folding Instructions****NOTE**

Throughout folding process, brush away stones, grass, and other debris on Tank Envelope.

1. Remove Dust Cap (Figure 12, Item 1) from Flanged Adapter (Figure 12, Item 2) on Tank Envelope (Figure 12, Item 3).
2. Working from sides of Tank Envelope (Figure 12, Item 3), tightly fold both sides towards center of Tank Envelope (Figure 12, Item 3) and stop at Flanged Adapter (Figure 12, Item 2). Brush away stones, dirt, twigs and debris on Tank Envelope fabric. Tightly fold both sides towards center of Tank Envelope (Figure 12, Item 3) again.
3. Roll Tank Envelope (Figure 12, Item 3) ends toward Flanged Adapter (Figure 12, Item 2).
4. Place two Lifting Slings (Figure 12, Item 4) around Tank Envelope (Figure 12, Item 3).
5. Remove rolled Tank Envelope (Figure 12, Item 3) from berm (Figure 12, Item 5).

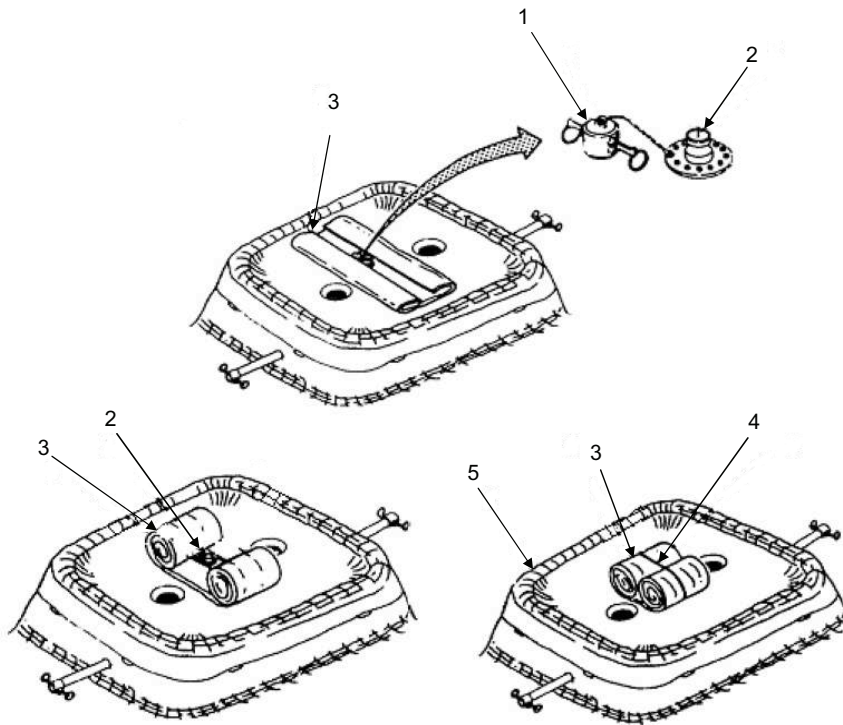

Figure 12. Tank Envelope Folding Procedures.

PREPARATION FOR MOVEMENT – CONTINUED

Packing and Folding Instructions for Berm Liner

NOTE

Field Maintenance must remove Berm Liner Drain Hose Assembly, Bowl x Cam prior to folding Berm Liner.

1. Lift up one corner of Berm Liner with drain decal and flip over to expose Tank Envelope drain. There are two drain decals and two Tank Envelope drains.
2. Field Maintenance will remove Tank Drain Hose and replace with Blind Flange Cover.
3. Wrap Tank Drain Hose hardware with permanently attached cushioning material and secure with pressure sensitive tape (WP 0075, Item 10).
4. If applicable, lay corner back so that Berm Liner is flat. Pick up corner of Berm Liner with drain decal to uncover second drain fitting. Repeat steps 2 and 3.
5. Stand facing long side of Berm Liner. Berm liner is folded wig-wag, as follows:
 - a. Start with left edge of Berm Liner. Lift up long side of Berm Liner closest to you, and fold 40 in. from center (Figure 13, Fold 1).
 - b. Lifting same long side edge as in first fold, fold back towards outside edge, 40 in. (101.6 cm) (Figure 13, Fold 2).
 - c. Lifting same long side edge as in first and second folds, fold back toward center of Berm Liner, so top fold is 40 in. (101.6 cm) (Figure 13, Fold 3).
 - d. Continue folding this way until last fold is 40 in. (101.6 cm) or less.
 - e. Go to opposite side of Berm Liner. Lift long edge and fold over existing 40 in. (101.6 cm) folds.
 - f. Lift up same edge and fold back over previous folds, and continue folding wig-wag, until top of fold measures 40 in. (101.6 cm) to 42 in. (106.7 cm) (Figure 13, Fold 4).

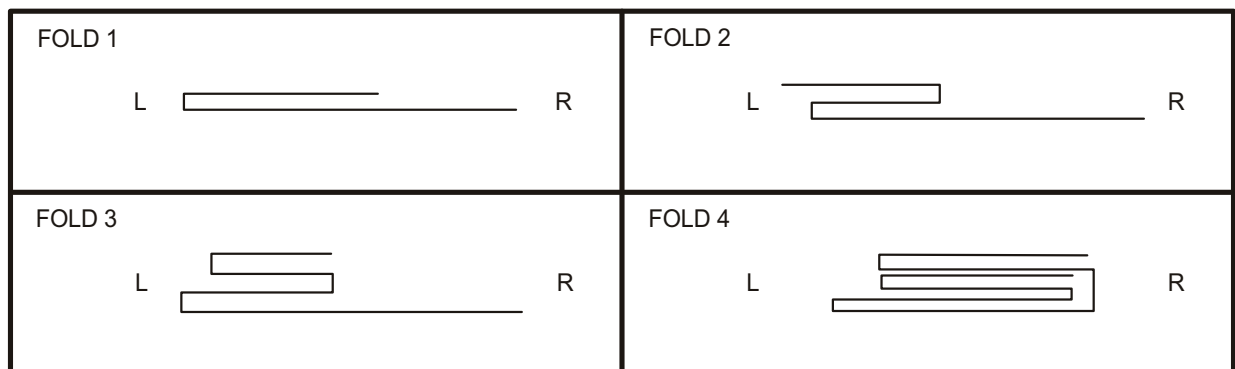

Figure 13. Tank Envelope Folding.

PREPARATION FOR MOVEMENT – CONTINUED

- g. Berm liner is now folded into a long narrow rectangle. Stand at one end of long rectangle.
- h. Pick up end edge of Berm Liner and fold it over so fold measures 58 in. (147.3 cm) (Figure 14, Fold 1).
- i. Fold Berm Liner over again, so second fold is slightly longer (Figure 14, Fold 2).
- j. Continue folding until you arrive at halfway point.
- k. Starting at opposite end of Berm Liner, fold 58 in. (147.3 cm) (Figure 14, Fold 3).
- l. Continue folding over and over until this bundle is 18 in. (45.72 cm) from opposite bundle (Figure 14, Fold 4).

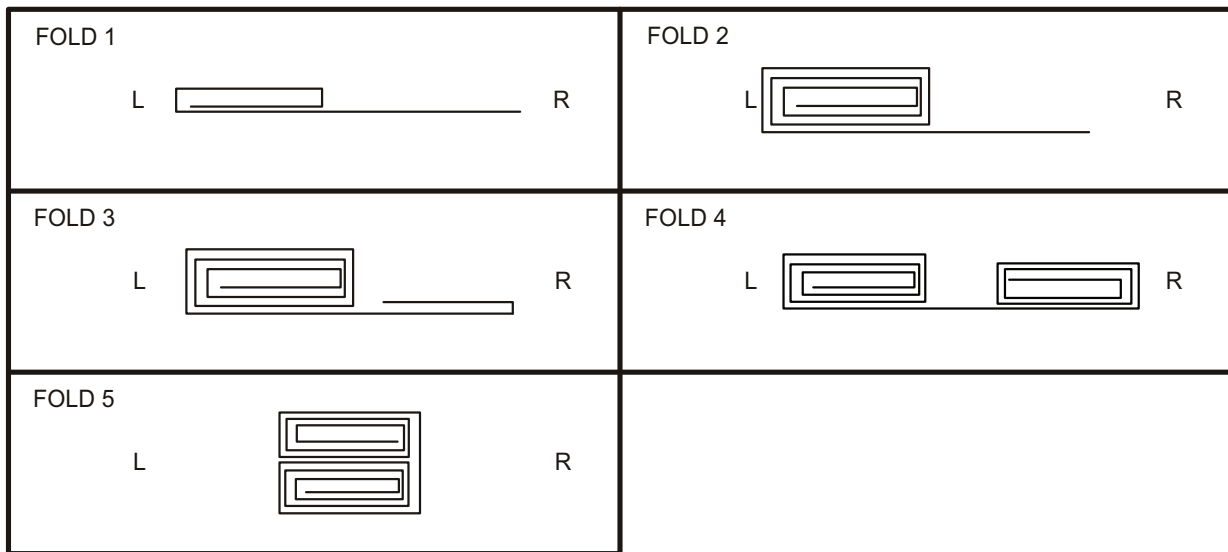

Figure 14. Berm Liner Folding.

- m. Fold entire smaller bundle up and on top of opposite end folds. Package measures 59 in. (149.9 cm) x 44 in. (111.8 cm) x 17 in. (43.18 cm).
6. Slide Lifting Slings under Berm Liner from either side, adjusting until Lifting Slings are 18 in. (45.72 cm) from edges of Berm Liner package.
 7. Lift Berm Liner from side edge by looping Lifting Slings over forks of forklift truck.
 8. Lower folded Berm Liner package into box from back of box (markings and address label are on front). Berm liner should be flush with front edge of box.

END OF TASK

END OF WORK PACKAGE

OPERATOR INSTRUCTIONS
OPERATION UNDER UNUSUAL CONDITIONS AND EMERGENCY REPAIR PROCEDURES

INITIAL SETUP:**Personnel Required**

Petroleum Supply Specialist 92F (2)

References

FM 3-3

FM 3-11.4

FM 3-4

FM 3-11.5

OPERATION IN EXTREME HEAT

1. Avoid unnecessary handling of Tank Envelope at temperatures above 160°F (71°C). Separation of the coating material is possible in extremely high temperatures.
2. If possible, set up protective shade over Tank Envelope being careful not to block air circulation.

END OF TASK**OPERATION IN EXTREME COLD****Prep Tank Prior to Operational Deployment**

1. Avoid any unnecessary handling of Tank Envelope.
2. If possible, deploy Tank Envelope only when temperature is above -25°F (-32°C).

CAUTION

In extreme cold, a new Tank Envelope must be prepared for initial operations. Tank Envelope will crack if seams formed in material from depot vacuum packing are not stretched out prior to Tank Envelope being filled with fuel.

3. Remove Tank Envelope from packing crate and unfold it to allow seams created by depot vacuum packing to stretch out.
4. If possible, inflate Tank Envelope with compressed air to ensure all seams are stretched out.
5. Keep snow and ice from accumulating on top of Tank Envelope and Vent Port Assembly.
6. Keep snow and ice from accumulating on couplings to ensure proper assembly and disassembly.
7. Avoid unnecessary folding, unfolding, or rolling of Tank Envelope that might cause flaking, cracking, or delaminating of coating material.
8. Sweep snow from exterior of Tank Envelope with soft-bristled broom or brush.
9. Cover fittings to keep ice from forming on Filler/Discharge Assemblies.
10. Refold and repack Tank Envelope after seams have been stretched out.

END OF TASK

OPERATION IN SANDY OR DUSTY AREAS

1. Cover all hoses and fittings not in use with Dust Caps to prevent sand or dust from contaminating fuel.
2. Ensure that Filler/Discharge Elbows are free of sand or dirt prior to filling or drawing fuel from Tank Envelope.
3. Keep Tank Envelope, Vent Port Assembly, and ball valve clear of sand, dust and grime.
4. Wipe couplings clean before assembly.

END OF TASK**OPERATION AT HIGH ALTITUDES**

No special procedures are required for operation at high altitudes.

END OF TASK**OPERATION IN MUD**

Ensure that ball valves and fittings are clean before filling or discharging fuel from Tank Envelope.

END OF TASK**OPERATION IN HIGH WINDS**

1. If only partially filled, Tank Envelope could roll over in windy conditions.

CAUTION

To avoid damage to equipment, do not attach restraining straps or ropes to Tank Envelope handles.

2. Secure Tank Envelope with suitable restraining straps or ropes (Figure 1) if high winds are expected.
3. Pass restraining straps or ropes under and over Tank Envelope and fasten securely to stakes in ground.

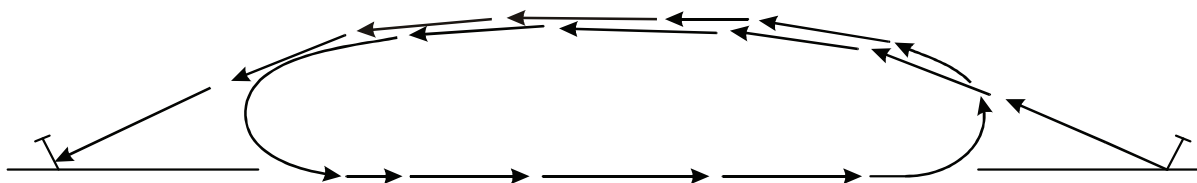

Figure 1. Tank Envelope Restraining Straps.

END OF TASK

OPERATION IN RAIN

If possible, provide adequate drainage ditches to prevent water from accumulating around Tank Envelope.

END OF TASK

EMERGENCY REPAIR PROCEDURES

General

Emergency repair is performed when cuts or punctures occur in Tank Envelope while in use. Emergency Repair Kit is stored in partition on inside wall of Tank Envelope shipping container. Cuts or tears in Tank Envelope smaller than 6.5 in. (16.51 cm) are repaired with Mechanical Patches. Small punctures are repaired using Wood Plugs. Damage larger than 6.5 in. (16.51 cm) requires replacement of Tank Envelope.

Emergency Repairs with Wood Plugs

In emergencies, as an immediate temporary measure, Wood Plugs can be used for sealing small holes or punctures. Size of hole or tear will determine size of Wood Plug to be used.

1. Select size of Wood Plug needed to seal Tank Envelope puncture (Figure 2):
 - For punctures up to approximately 0.5-in. (1.27 cm) in size, use 5/8-in. (1.59-cm) Wood Plug.
 - For punctures up to approximately 1-in. (2.54 cm) in size, use 1.5-in. (3.81-cm) Wood Plug.
 - For punctures up to approximately 1.5-in. (3.81 cm) in size, use 2-in. (5.08-cm) Wood Plug.



Figure 2. Wood Plug Installation.

2. Wet Wood Plug and insert in Tank Envelope puncture (Figure 2).
3. Twist Wood Plug clockwise until leak is stopped.

NOTE

Follow-up regular inspection should be made of Wood Plugs, as possible tightening may be necessary if leak resumes.

4. Use Mechanical Patch if leak is not stopped.

END OF TASK

EMERGENCY REPAIR PROCEDURES – CONTINUED

Emergency Repairs with Mechanical Patches

Small slits, tears, or cuts, not to exceed 6.5 in. (16.51 cm) in length, may be repaired with Mechanical Patches.

Size of damaged area (opening) needing repair will govern size of Mechanical Patch needed. It may be necessary to increase size of fabric tear in order to be able to insert bottom plate Mechanical Patch through tear.

1. Select Mechanical Patch that is at least 1 in. (2.54 cm) larger than tear:
 - For holes (tears) less than 2 in. (5.08 cm) in length, use 3-in. (7.62-cm) Mechanical Patch.
 - For holes (tears) 2 to 4 in. (5.08 to 10.16 cm) in length, use 5-in. (12.7-cm) Mechanical Patch.
 - For holes (tears) 4 to 6.5 in. (10.16 to 16.51 cm) in length, use 7.5-in. (19-cm) Mechanical Patch.

CAUTION

Use extreme care when enlarging a tear. Tension in fabric may cause fabric to tear further.

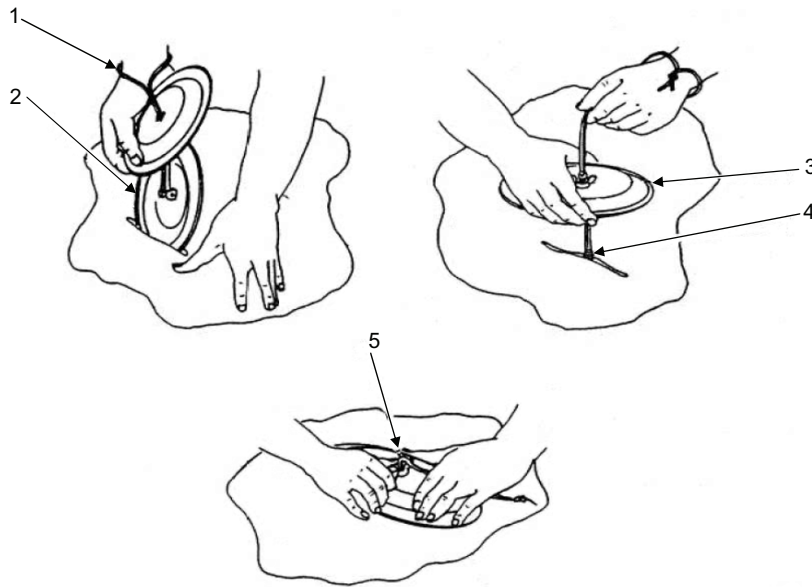

Figure 3. Mechanical Patch Installation.

2. Loop cord (Figure 3, Item 1) around wrist to prevent loss of Mechanical Patch (Figure 3, Item 2) into Tank Envelope.
3. Slip bottom plate of Mechanical Patch (Figure 3, Item 2) through hole or tear and rotate it until it is centered and its length runs with tear.
4. Pull bottom plate (Figure 3, Item 2) up against fabric and slide top plate (Figure 3, Item 3) and Wing Nut (Figure 3, Item 5) down cord and onto threaded stud (Figure 3, Item 4) of bottom plate (Figure 3, Item 2).

EMERGENCY REPAIR PROCEDURES – CONTINUED**CAUTION**

Do not over-tighten Wing Nut. Stud threads may strip or cause damage to Tank Envelope fabric.

5. With plates (Figure 3, Item 3) aligned, tighten Wing Nut (Figure 3, Item 5) clamping Tank Envelope wall between two plates (Figure 3, Item 2). Tighten Wing Nut (Figure 3, Item 5) enough to stop leak.

END OF TASK**INTERIM CHEMICAL, BIOLOGICAL, RADIOLOGICAL, AND NUCLEAR (CBRN) DECONTAMINATION PROCEDURES****WARNING**

If equipment has been exposed to chemical, biological, radiological, or nuclear warfare, equipment shall be handled with extreme caution and decontaminated in accordance with FM 3-11.5, Multiservice Tactics, Techniques, and Procedures for Chemical, Biological, Radiological, and Nuclear (CBRN) Decontamination. Unprotected personnel can be injured or killed if residual toxic agents or radioactive materials are present. If equipment is exposed to chemical, biological, radiological, or nuclear agents, personnel must wear protective mask, hood, protective overgarments, chemical gloves, and chemical boots in accordance with Mission Oriented Protective Posture (MOPP) level prescribed by Officer in Charge (OIC) or Non-Commissioned Officer in Charge (NCOIC). MOPP analysis and levels are described in detail in FM 3-11.4, Multiservice Tactics, Techniques, and Procedures for Nuclear, Biological, and Chemical (NBC) Protection. Personnel should contact a unit that has capability for freshwater wash down. Unit can also assist in evacuation of soldiers who have been exposed and provide space and shelter for exchanging MOPP suits.

NOTE

For detailed decontamination procedures, refer to FM 3-3, Chemical and Biological Contamination Avoidance, FM 3-4, NBC Protection, and FM 3-11.5, Multiservice Tactics, Techniques, and Procedures for Chemical, Biological, Radiological, and Nuclear (CBRN) Decontamination.

GENERAL

The following emergency procedures can be performed until field CBRN decontamination facilities are available.

CBRN EMERGENCY PROCEDURES**WARNING**

If CBRN attack is known or suspected, don mask immediately and continue mission. Mask should not be removed until instructed to do so.

1. Nuclear/Radiological decontamination – Brush fallout from skin, clothing, and equipment with available brushes, rags, or tree branches. Wash skin and undergo radiation check as soon as tactical situation permits.
2. Biological decontamination – Remain masked and continue mission until instructed to unmask.

CBRN EMERGENCY PROCEDURES – CONTINUED

3. Chemical detection and decontamination –

WARNING

Do not use decontamination spray on personnel. It could cause personal injury.

- a. Use M8 paper from M256 chemical agent detector kit or M9 paper to determine if liquid agent is present on surface of equipment.
- b. If M8 or M9 paper indicates liquid chemical agent is present, rinse exposed portion of Tank Envelope with liberal amount of water. When tactical situation permits, wash Tank Envelope with soapy water and rinse.
- c. If exposure to liquid agent is known or suspected, clean all exposed skin, clothing, and personal gear in that order using M258A1 kit. Use buddy system. Wash exposed skin and thoroughly decontaminate as soon as tactical situation permits. Decontamination procedures take time based on tactical situation.

END OF TASK**END OF WORK PACKAGE**

CHAPTER 3

**OPERATOR TROUBLESHOOTING PROCEDURES
FOR
TANK, FABRIC, COLLAPSIBLE, FUEL STORAGE,
20,000 GALLON**

**OPERATOR MAINTENANCE
MASTER MALFUNCTION/SYMPTOM INDEX**

MALFUNCTION/SYMPTOM

TROUBLESHOOTING PROCEDURE

GENERAL

- 1. Tank Assembly Operational Checkout..... WP 0008
- 2. Tank Assembly Leakage..... WP 0009
- 3. Shutoff Valve from Fuel Source Host System WP 0010
- 4. Filler/Discharge Hose Assembly WP 0011
- 5. Tank Drain Ball Valve Assembly WP 0012
- 6. Tank Drain Hose Assembly..... WP 0013
- 7. Vent Port Assembly WP 0014
- 8. Cap and Flame Arrestor Assembly, Passive Vent WP 0015
- 9. Filler/Discharge Assembly WP 0016
- 10. Tank Drain Fitting Assembly WP 0017
- 11. Berm Liner Drain Fitting Assembly..... WP 0018
- 12. Berm Liner Drain Ball Valve Assembly WP 0019
- 13. Emergency Repair Kit and Spare Parts WP 0020

END OF TASK

END OF WORK PACKAGE

**OPERATOR MAINTENANCE
TANK ASSEMBLY
OPERATIONAL CHECKOUT**

INITIAL SETUP:**Personnel Required**

Petroleum Supply Specialist 92F

References

WP 0004

WP 0005

WP 0006

OPERATIONAL CHECKOUT OF THE 20,000 GALLON FUEL STORAGE COLLAPSIBLE FABRIC TANK

When required, operational check shall be used to verify repair of individual parts and components of Tank Assembly. Once completed, return to associated troubleshooting work package.

STEPS

1. Repair parts or replacement components that were removed from Tank Assembly are installed as applicable.
2. Place Tank Assembly into operation (WP 0004 and WP 0005).
3. Verify part or component is operating correctly.
4. Inspect part or component that has been repaired, replaced, or determined to be operating improperly or leaking.

CONDITION/INDICATION

Tank Assembly component or part still does not operate correctly or still leaks.

CORRECTIVE ACTION

1. Shut down operation and perform repair procedures (WP 0006).
2. If not repaired, repeat repair steps or continue on with troubleshooting as applicable.

END OF WORK PACKAGE

**OPERATOR MAINTENANCE
TANK ASSEMBLY LEAKAGE
TROUBLESHOOTING PROCEDURES**

INITIAL SETUP:**Personnel Required**

Petroleum Supply Specialist 92F

References

WP 0006

TROUBLESHOOTING PROCEDURES**TANK ASSEMBLY LEAKAGE****WARNING**

Fuel vapors are extremely flammable. Exercise care to prevent sparks when working near Tank Assembly. Death or severe personal injury can result if safety precautions are not strictly observed.

SYMPTOM

Tank Envelope leaks.

MALFUNCTION

Tank Envelope has cuts, tears, punctures or damaged seams.

CORRECTIVE ACTION

1. Perform emergency repairs using Wood Plugs or Mechanical Patches (WP 0006).
2. If leaks continue, notify Field Maintenance.

END OF WORK PACKAGE

**OPERATOR MAINTENANCE
SHUTOFF VALVE FROM FUEL SOURCE HOST SYSTEM
TROUBLESHOOTING PROCEDURES**

INITIAL SETUP:**Personnel Required**

Petroleum Supply Specialist 92F

TROUBLESHOOTING PROCEDURES**SHUTOFF VALVE FROM FUEL SOURCE HOST SYSTEM****WARNING**

Fuel vapors are extremely flammable. Exercise care to prevent sparks when working near Tank Assembly. Death or severe personal injury can result if safety precautions are not strictly observed.

SYMPTOM

Shutoff valve from fuel source host system leaks.

MALFUNCTION

Shutoff valve from fuel source host system is not closed completely.

CORRECTIVE ACTION

1. Tightly close shutoff valve from fuel source host system.
2. Replace Gasket if damaged or missing. (Refer to the appropriate Class III system technical manual for repair procedures.)

MALFUNCTION

Shutoff valve from fuel source host system is damaged or worn.

CORRECTIVE ACTION

Notify Field Maintenance.

MALFUNCTION

Shutoff valve from fuel source host system is improperly aligned.

CORRECTIVE ACTION

1. Align shutoff valve from fuel source host system.
2. If still leaking, notify Field Maintenance.

END OF WORK PACKAGE

**OPERATOR MAINTENANCE
FILLER/DISCHARGE HOSE ASSEMBLY
TROUBLESHOOTING PROCEDURES**

INITIAL SETUP:**Personnel Required**

Petroleum Supply Specialist 92F

References

WP 0025

TROUBLESHOOTING PROCEDURES**FILLER/DISCHARGE HOSE ASSEMBLY****WARNING**

Fuel vapors are extremely flammable. Exercise care to prevent sparks when working near tank. Death or severe personal injury can result if safety precautions are not strictly observed.

SYMPTOM

Filler/Discharge Hose or couplings leak.

MALFUNCTION

Filler/Discharge Hose is torn or broken.

CORRECTIVE ACTION

Notify Field Maintenance.

MALFUNCTION

Gasket is damaged or worn.

CORRECTIVE ACTION

1. Replace Gasket between Hose and shutoff valve from fuel source host system. (Refer to the appropriate Class III system technical manual for repair procedures.)
2. Replace Gasket between Hose and Filler/Discharge Elbow (WP 0025).

MALFUNCTION

Filler/Discharge Hose coupling is dirty, damaged, or worn.

CORRECTIVE ACTION

1. Remove dirt or debris from inside Filler/Discharge Hose coupling.
2. If still leaking, notify Field Maintenance.

END OF WORK PACKAGE

**OPERATOR MAINTENANCE
TANK DRAIN BALL VALVE ASSEMBLY
TROUBLESHOOTING PROCEDURES**

INITIAL SETUP:**Personnel Required**

Petroleum Supply Specialist 92F

References

WP 0023

TROUBLESHOOTING PROCEDURES**TANK DRAIN BALL VALVE ASSEMBLY****WARNING**

Fuel vapors are extremely flammable. Exercise care to prevent sparks when working near tank. Death or severe personal injury can result if safety precautions are not strictly observed.

SYMPTOM

Drain Ball Valve Assembly leaks.

MALFUNCTION

Drain Valve is not closed completely.

CORRECTIVE ACTION

1. Tightly close Drain Valve.
2. Replace Gasket if damaged or missing (WP 0023).

MALFUNCTION

Drain Valve is damaged or worn.

CORRECTIVE ACTION

Notify Field Maintenance.

MALFUNCTION

Drain Valve is not properly aligned.

CORRECTIVE ACTION

1. Align Drain Valve.
2. If still leaking, notify Field Maintenance.

END OF WORK PACKAGE

**OPERATOR MAINTENANCE
TANK DRAIN HOSE ASSEMBLY
TROUBLESHOOTING PROCEDURES**

INITIAL SETUP:**Personnel Required**

Petroleum Supply Specialist 92F

TROUBLESHOOTING PROCEDURES**TANK DRAIN HOSE ASSEMBLY****WARNING**

Fuel vapors are extremely flammable. Exercise care to prevent sparks when working near tank. Death or severe personal injury can result if safety precautions are not strictly observed.

SYMPTOM

Tank Drain Hose Assembly leaks.

MALFUNCTION

Tank Drain Hose Assembly is broken or leaks.

CORRECTIVE ACTION

Notify Field Maintenance.

END OF WORK PACKAGE

**OPERATOR MAINTENANCE
VENT PORT ASSEMBLY
TROUBLESHOOTING PROCEDURES**

INITIAL SETUP:**Personnel Required**

Petroleum Supply Specialist 92F

References

WP 0024

TROUBLESHOOTING PROCEDURES**VENT PORT ASSEMBLY****WARNING**

Fuel vapors are extremely flammable. Exercise care to prevent sparks when working near tank. Death or severe personal injury can result if safety precautions are not strictly observed.

SYMPTOM

Vent Port Assembly leaks.

MALFUNCTION

Gasket between Coupling Half and Flanged Adapter leaks.

CORRECTIVE ACTION

Replace Gasket (WP 0024).

MALFUNCTION

Vent Port Assembly continues to leak.

CORRECTIVE ACTION

Notify Field Maintenance.

END OF WORK PACKAGE

**OPERATOR MAINTENANCE
CAP AND FLAME ARRESTOR ASSEMBLY, PASSIVE VENT
TROUBLESHOOTING PROCEDURES**

INITIAL SETUP:**Personnel Required**

Petroleum Supply Specialist 92F

TROUBLESHOOTING PROCEDURES**VENT CAP AND FLAME ARRESTOR****WARNING**

Fuel vapors are extremely flammable. Exercise care to prevent sparks when working near tank. Death or severe personal injury can result if safety precautions are not strictly observed.

SYMPTOM

Vent Cap does not operate freely.

MALFUNCTION

Vent Cap leaks, is not clean, or binds.

CORRECTIVE ACTION

Notify Field Maintenance.

END OF WORK PACKAGE

**OPERATOR MAINTENANCE
FILLER/DISCHARGE ASSEMBLY
TROUBLESHOOTING PROCEDURES**

INITIAL SETUP:**Personnel Required**

Petroleum Supply Specialist 92F

References

WP 0025

TROUBLESHOOTING PROCEDURES**FILLER/DISCHARGE ASSEMBLY****WARNING**

Fuel vapors are extremely flammable. Exercise care to prevent sparks when working near tank. Death or severe personal injury can result if safety precautions are not strictly observed.

SYMPTOM

Filler/Discharge Assembly leaks.

MALFUNCTION

Gasket between Filler/Discharge Elbow and Flanged Adapter leaks.

CORRECTIVE ACTION

Replace Gasket (WP 0025).

MALFUNCTION

Filler/Discharge Assembly continues to leak.

CORRECTIVE ACTION

Notify Field Maintenance.

END OF WORK PACKAGE

**OPERATOR MAINTENANCE
TANK DRAIN FITTING ASSEMBLY
TROUBLESHOOTING PROCEDURES**

INITIAL SETUP:**Personnel Required**

Petroleum Supply Specialist 92F

TROUBLESHOOTING PROCEDURES**TANK DRAIN FITTING ASSEMBLY****WARNING**

Fuel vapors are extremely flammable. Exercise care to prevent sparks when working near tank. Death or severe personal injury can result if safety precautions are not strictly observed.

SYMPTOM

Tank Drain Fitting Assembly leaks between Blind Flange Cover and Tank Envelope fitting.

MALFUNCTION

Washers or Screws are missing or loose.

CORRECTIVE ACTION

Notify Field Maintenance.

MALFUNCTION

Gasket between Blind Flange Cover and Tank Envelope fitting is nicked, broken, or compressed.

CORRECTIVE ACTION

If damaged, notify Field Maintenance.

MALFUNCTION

Blind Flange Cover is damaged or cracked.

CORRECTIVE ACTION

Notify Field Maintenance.

END OF WORK PACKAGE

**OPERATOR MAINTENANCE
BERM LINER DRAIN FITTING ASSEMBLY
TROUBLESHOOTING PROCEDURES**

INITIAL SETUP:**Personnel Required**

Petroleum Supply Specialist 92F

TROUBLESHOOTING PROCEDURES**BERM LINER DRAIN FITTING ASSEMBLY****WARNING**

Fuel vapors are extremely flammable. Exercise care to prevent sparks when working near tank. Death or severe personal injury can result if safety precautions are not strictly observed.

SYMPTOM

Berm Liner Drain Fitting Assembly leaks between Blind Flange Cover and Berm Liner.

MALFUNCTION

Berm Liner Drain Fitting Assembly and Gaskets leak.

CORRECTIVE ACTION

Notify Field Maintenance.

END OF WORK PACKAGE

**OPERATOR MAINTENANCE
BERM LINER DRAIN BALL VALVE ASSEMBLY
TROUBLESHOOTING PROCEDURES**

INITIAL SETUP:**Personnel Required**

Petroleum Supply Specialist 92F

TROUBLESHOOTING PROCEDURES**BERM LINER DRAIN VALVE ASSEMBLY****WARNING**

Fuel vapors are extremely flammable. Exercise care to prevent sparks when working near tank. Death or severe personal injury can result if safety precautions are not strictly observed.

SYMPTOM

Berm Liner Drain Valve Assembly leaks.

MALFUNCTION

Berm Liner Drain Valve is not closed completely.

CORRECTIVE ACTION

Tightly close Berm Liner Drain Valve.

MALFUNCTION

Berm Liner Drain Valve is damaged or worn.

CORRECTIVE ACTION

Notify Field Maintenance.

MALFUNCTION

Berm Liner Drain Valve is improperly aligned.

CORRECTIVE ACTION

1. Align Berm Liner Drain Valve.
2. If still leaking, notify Field Maintenance.

END OF WORK PACKAGE

**OPERATOR MAINTENANCE
EMERGENCY REPAIR KIT AND SPARE PARTS
TROUBLESHOOTING PROCEDURES**

INITIAL SETUP:**Personnel Required**

Petroleum Supply Specialist 92F

References

WP 0068

TROUBLESHOOTING PROCEDURES**EMERGENCY REPAIR ITEMS AND SPARE PARTS****WARNING**

Fuel vapors are extremely flammable. Exercise care to prevent sparks when working near tank. Death or severe personal injury can result if safety precautions are not strictly observed.

SYMPTOM

Inspect contents of Emergency Repair Kit and spare parts.

MALFUNCTION

Emergency Repair Kit items or spare parts are missing from tank crate.

CORRECTIVE ACTION

Replace missing Emergency Repair Kit items or spare parts (WP 0068).

END OF WORK PACKAGE

CHAPTER 4

**OPERATOR MAINTENANCE INSTRUCTIONS
FOR
TANK, FABRIC, COLLAPSIBLE, FUEL STORAGE,
20,000 GALLON**

**OPERATOR MAINTENANCE
PREVENTIVE MAINTENANCE CHECKS AND SERVICES (PMCS) INTRODUCTION**

INTRODUCTION**GENERAL**

Preventive Maintenance Checks and Services (PMCS) are performed to keep the Tank Assembly in operating condition. The checks are used to find, correct or report problems. Operators should perform the PMCS as shown in the PMCS table. Using the PMCS table, preventive maintenance checks and services are performed every day the equipment is operated, give attention to WARNING and CAUTION statements. A WARNING indicates that someone could be injured or killed. A CAUTION indicates the possibility of equipment damage.

Before operating the equipment, **BEFORE** Preventive Maintenance Checks Services (PMCS) should be conducted.

Perform **DURING** PMCS during equipment operation.

AFTER PMCS should be performed upon completion of equipment operation.

Use troubleshooting and/or maintenance procedures to correct problems found when performing PMCS.

The right-hand column of the PMCS table lists conditions that classify the equipment as *not fully mission capable*. Report items as *not-fixed* on DA Form 2404 or DA Form 5988-E for Field Maintenance. For further information on how to use this form, see DA PAM 750-8.

If tools are required to perform PMCS and not listed in WP 0073, notify Field Maintenance.

LEAKAGE DEFINITIONS**CAUTION**

Equipment operation is allowed with minor leakage (Class I or II). Of course, consideration must be given to the fluid capacity of the item or system being checked. When in doubt, ask your supervisor.

When operating with Class I or II leaks, continue to check for fuel levels as required in your PMCS.

If there is a Class III leak, shut down operation immediately, and report it to your supervisor.

It is important to understand how fluid leakage affects the status of the Tank Assembly. Following are definitions of the leakage classes the operator needs to become familiar with in order to be able to determine the condition of the leak. Remember, when in doubt, always consult your supervisor.

Leakage classification for PMCS:

CLASS I - Seepage of fluid (as indicated by wetness or discoloration) not great enough to form drops.

CLASS II - Leakage of fluid great enough to form drops but not enough to cause drops to drip from item being inspected.

CLASS III - Leakage of fluid great enough to form drops that fall from the item being inspected.

INSPECTION

Look for signs of a problem or trouble. You can feel, smell, hear or see many problems. Be alert when using the equipment.

Inspect to ensure Items are in good condition. Are they correctly assembled, stowed, secured, excessively worn, leaking, corroded or properly lubricated? Correct any problems found or notify Field Maintenance.

The following are common items to check throughout the equipment:

1. Bolts, nuts and camlock levers: Continually check for looseness. Look for rust or corrosion around bolt and nuts and tighten when loose. If tools are not available, contact Field Maintenance.
2. Seams: There are many seams on the tank. Inspect for tears or deterioration.
3. Hoses: Look for wear, damage, and leaks. Ensure that fittings are tight. Wet spots indicate leakage. A stain near a fitting or connector can also indicate leakage. If a leakage is discovered, notify Field Maintenance.

CORROSION PREVENTION AND CONTROL (CPC)

Corrosion Prevention and Control (CPC) of Army materiel is a continuing concern. It is important that any corrosion problems with this item be reported so corrections and improvements can be made to prevent problems in future items.

Corrosion is typically associated with rusting of metals or galvanic corrosion, which produces a white powder. Corrosion also includes deterioration of other materials, such as rubber and plastic. Unusual cracking, softening, swelling or breaking of the materials may indicate corrosion problems. If a corrosion problem is identified, it can be reported using SF 368 Product Quality Deficiency Report. Use of key words, such as "corrosion," "rust," "deterioration," or "cracking," will ensure that the information is identified as a CPC problem. The form should be submitted to the address specified in DA PAM 750-8.

ARMY OIL ANALYSIS PROGRAM (AOAP)

This Tank Assembly is not enrolled in the Army Oil Analysis Program.

END OF TASK

END OF WORK PACKAGE

**OPERATOR MAINTENANCE
PREVENTIVE MAINTENANCE CHECKS AND SERVICES (PMCS) AND
LUBRICATION PROCEDURES**

INITIAL SETUP:

Personnel Required

Petroleum Supply Specialist 92F (2)

PMCS AND LUBRICATION PROCEDURES

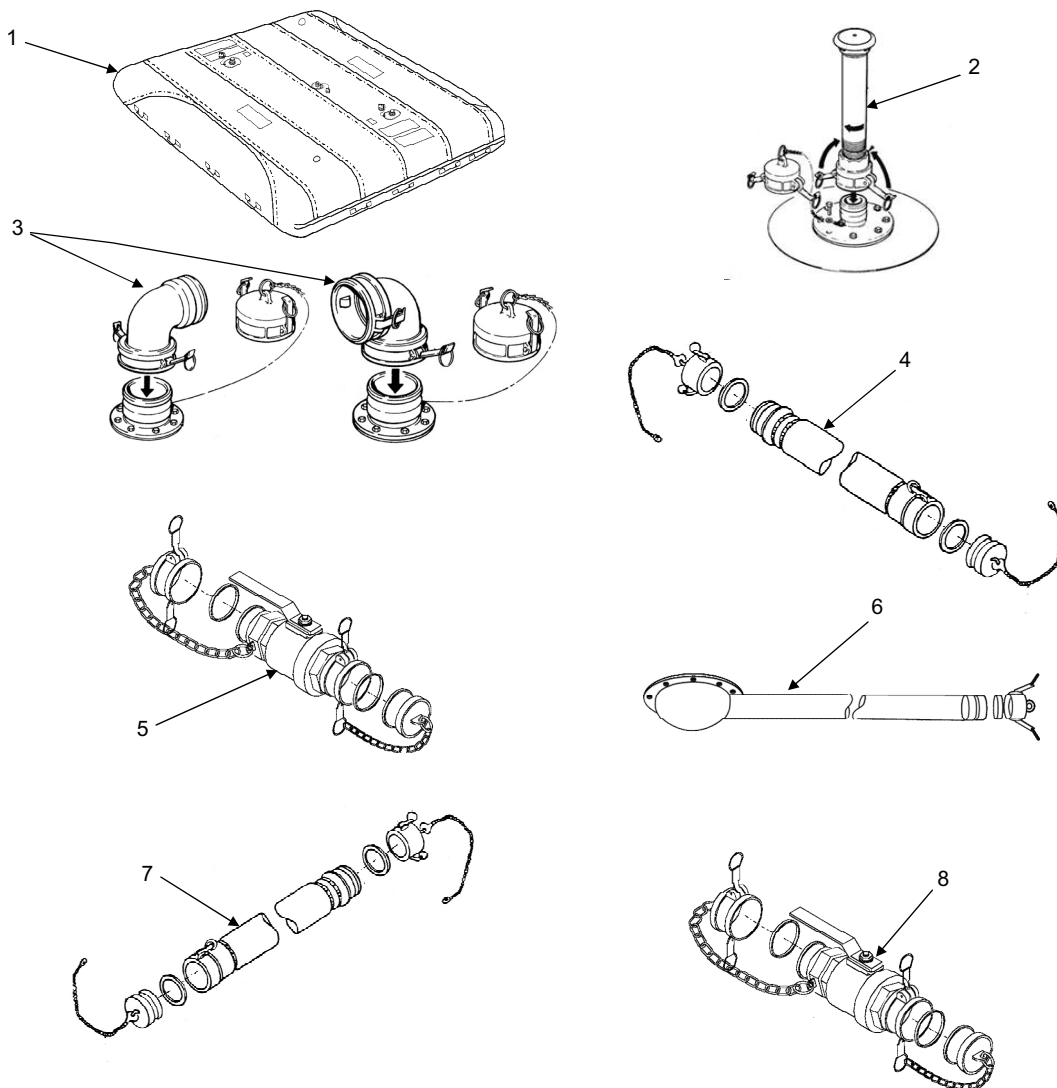

PMCS AND LUBRICATION PROCEDURES – CONTINUED

Table 1. Preventive Maintenance Checks and Services (Before PMCS).

ITEM NO.	INTERVAL	ITEM TO BE CHECKED OR SERVICED	PROCEDURE	EQUIPMENT NOT READY/ AVAILABLE IF:
1	Before	Tank Envelope	Inspect for tears or punctures. NOTE Air pockets trapped between tank envelope and interior chafing patches sometimes occur during manufacturing and do not affect the functionality of the tank.	Tank Envelope has tears or punctures that cannot be repaired.
2	Before	Vent Port Assembly	<ol style="list-style-type: none"> 1. Check Vent Cap, Flame Arrestor, Vent Pipe Assembly, and cam-lever arms for evidence of leakage, damage, or missing parts. 2. Check Vent Cap for cleanliness and freedom of operation. Check for damaged or missing Gaskets. 3. Check for damaged or missing Gaskets. 	<p>Vent Cap, Flame Arrestor, or Vent Pipe Assembly is damaged or missing.</p> <p>Vent Cap or cam-lever arms are damaged or missing.</p> <p>Gasket(s) are damaged or missing.</p>
3	Before	Filler/Discharge Elbow	<ol style="list-style-type: none"> 1. Check cam-lever arms and Filler/Discharge Elbows for damage. 2. Check for damaged or missing Gaskets. 	<p>Cam-lever arms damaged or missing.</p> <p>Filler/Discharge Elbow cracked or worn.</p> <p>Gasket(s) are damaged or missing.</p>
4	Before	Filler/Discharge Hose Assembly	<ol style="list-style-type: none"> 1. Check for cuts and tears. 2. Check fittings for distortion and damage, or missing Gaskets, Dust Caps and Dust Plugs. 	<p>Filler/Discharge Hose Assembly is damaged.</p> <p>Gaskets, Dust Caps or Dust Plugs are damaged or missing.</p>

PMCS AND LUBRICATION PROCEDURES – CONTINUED

Table 1. Preventive Maintenance Checks and Services - (Before PMCS) Continued.

ITEM NO.	INTERVAL	ITEM TO BE CHECKED OR SERVICED	PROCEDURE	EQUIPMENT NOT READY/ AVAILABLE IF:
5	Before	Shutoff valve from fuel source host system	<ol style="list-style-type: none"> 1. Check for bent or binding handle and broken hardware. 2. Check Gasket and cam-lever arms for damage. 3. Check for missing or damaged Dust Caps and Dust Plugs. 	<p>Bent or binding handle, Gasket, or cam-lever arms are damaged or missing.</p> <p>Gasket(s) are damaged or missing.</p>
6	Before	Tank Drain Hose Assembly, Bowl x Cam	Check for cuts, holes, or tears, and damage to Tank Drain Hose Assembly, Bowl x Cam.	Tank Drain Hose Assembly, Bowl x Cam leaks or is damaged.
7	Before	Tank Drain Hose, Cam x Cam	Check for cuts, holes, and tears.	Tank Drain Hose leaks or is damaged.
8	Before	Tank Drain Ball Valve Assembly	<ol style="list-style-type: none"> 1. Check for bent or binding handle and broken hardware. 2. Check Gasket and cam-lever arms for damage. 3. Check for missing or damaged Dust Caps and Dust Plugs. 	<p>Handle damaged or missing.</p> <p>Gasket is damaged or missing.</p> <p>Dust Caps or Dust Plugs are damaged or missing.</p>
9	Before	Berm Liner Drain Hose Assembly	Check for cuts, holes, and tears.	Berm Liner Drain Hose leaks or is damaged.
10	Before	Berm Liner Drain Ball Valve Assembly	<ol style="list-style-type: none"> 1. Check for bent or binding handle and broken hardware. 2. Check Gasket and cam-lever arms for damage. 3. Check for missing or damaged Dust Caps and Dust Plugs. 	<p>Handle damaged or missing.</p> <p>Gasket is damaged or missing.</p> <p>Dust Caps or Dust Plugs are damaged or missing.</p>

PMCS AND LUBRICATION PROCEDURES – CONTINUED

Table 1. Preventive Maintenance Checks and

ITEM NO.	INTERVAL	ITEM TO BE CHECKED OR SERVICED	PROCEDURE	EQUIPMENT NOT READY/ AVAILABLE IF:
1	During	Tank Envelope	Inspect for tears, punctures, or leaks.	Tank Envelope has tears, punctures, or leaks that cannot be repaired.
2	During	Vent Port Assembly	<ol style="list-style-type: none"> 1. Check Vent Cap, Flame Arrestor and cam-lever arms for evidence of leakage, damage, or missing parts. 2. Check Vent Cap for cleanliness and freedom of operation. 3. Check for damaged or missing Gaskets. 	<p>Vent Cap or Flame Arrestor is damaged or missing.</p> <p>Vent Cap or cam-lever arms are damaged or missing.</p> <p>Gaskets are damaged or missing.</p>
3	During	Filler/Discharge Elbow Assembly	Check cam-lever arm and Filler/Discharge Elbows for damage or leaks.	<p>Cam-lever arms damaged or missing.</p> <p>Filler/Discharge Elbow is cracked.</p> <p>Filler/Discharge Elbow sealing surface is badly dented.</p>
4	During	Filler/Discharge Hose Assembly	<ol style="list-style-type: none"> 1. Check for leaks, cuts, and tears. 2. Check fittings for distortion or damage. 	Filler/Discharge Hose Assembly leaks or is damaged.
5	During	Shutoff valve from fuel source host system	Check for bent or binding handle, broken hardware, and leakage.	Handle, Gasket, or cam-lever arms are damaged, missing, or leaking.
6	During	Tank Drain Hose Assembly, Bowl x Cam	<ol style="list-style-type: none"> 1. Check for leaks, cuts, and tears. 2. Check fittings for distortion or damage. 	Tank Drain Hose Assembly, Bowl x Cam leaks or is damaged.

PMCS AND LUBRICATION PROCEDURES – CONTINUED

Table 1. Preventive Maintenance Checks and Services - Continued.

ITEM NO.	INTERVAL	ITEM TO BE CHECKED OR SERVICED	PROCEDURE	EQUIPMENT NOT READY/ AVAILABLE IF:
7	During	Tank Drain Hose Assembly	<ol style="list-style-type: none"> 1. Check for leaks, cuts, and tears. 2. Check fittings for distortion or damage. 	Tank Drain Hose leaks or is damaged.
8	During	Tank Drain Ball Valve Assembly	Check for bent or binding handle, broken hardware, and leakage.	Handle, Gasket, or cam-lever arms are damaged, missing, or leaking.
1	After	Tank Envelope	<p>Inspect for tears or punctures.</p> <p style="text-align: center;">NOTE</p> <p>Air pockets trapped between the tank envelope and the interior chafing patches sometimes occur during manufacturing. This does not affect the functionality of the tank.</p>	Tank Envelope has tears or punctures that cannot be repaired.
2	After	Vent Port Assembly	<ol style="list-style-type: none"> 1. Check Vent Cap, Flame Arrestor, and cam-lever arms for evidence of leaks, damage, or missing parts. 2. Check Vent Cap for cleanliness and freedom of operation. 3. Check for damaged or missing Gaskets. 	<p>Passive Vent Cap or Flame Arrestor is damaged or missing.</p> <p>Vent Cap or cam-lever arms are damaged or missing.</p> <p>Gaskets are damaged or missing.</p>
3	After	Filler/Discharge Elbow	Check cam-lever arms and Filler/Discharge Elbow for damage.	Cam-lever arms damaged or missing. Filler/Discharge Elbow is cracked or worn.
4	After	Filler/Discharge Hose Assembly	<ol style="list-style-type: none"> 1. Check for cuts and tears. 2. Check fittings for distortion and damage, or missing Gaskets, Dust Caps and plugs. 	<p>Hose assembly is damaged.</p> <p>Gaskets, Dust Caps or plugs are damaged or missing.</p>

PMCS AND LUBRICATION PROCEDURES – CONTINUED
Table 1. Preventive Maintenance Checks and Services - Continued.

ITEM NO.	INTERVAL	ITEM TO BE CHECKED OR SERVICED	PROCEDURE	EQUIPMENT NOT READY/ AVAILABLE IF:
5	After	Tank Drain Hose Assembly, Bowl x Cam	Check for cuts, holes, or tears to hose, and damage to Tank Drain Hose Assembly, Bowl x Cam.	Tank Drain Hose Assembly, Bowl x Cam leaks or is damaged.
6	After	Tank Drain Hose	Check for cuts, holes, and tears.	Tank Drain Hose leaks or is damaged.
7	After	Tank Drain Ball Valve	<ol style="list-style-type: none"> 1. Check for bent or binding handle and broken hardware. 2. Check Gasket and cam-lever arms for damage. 3. Check for missing or damaged Dust Caps and plugs. 	<p>Handle, Gasket, or cam-lever arms are damaged or missing.</p> <p>Gasket or cam-lever arms are damaged or missing.</p> <p>Damaged or missing Dust Caps and Dust Plugs.</p>
8	After	Berm Liner Drain Hose Assembly	Check for cuts, holes, and tears.	Berm Liner Drain Hose leaks or is damaged.
9	After	Berm Liner Drain Ball Valve	<ol style="list-style-type: none"> 1. Check for bent or binding handle and broken hardware. 2. Check Gasket and cam-lever arms for damage. 3. Check for missing or damaged Dust Caps and plugs. 	<p>Handle, Gasket, or cam-lever arms are damaged or missing.</p> <p>Gasket or cam-lever arms are damaged or missing.</p> <p>Damaged or missing Dust Caps and Dust Plugs.</p>

LUBRICATION INSTRUCTIONS

No lubrication required for this equipment.

END OF WORK PACKAGE

**OPERATOR MAINTENANCE
TANK/BERM LINER DRAIN BALL VALVE ASSEMBLY
REPAIR**

INITIAL SETUP:**Materials/Parts**

Gasket (2) (WP 0076, Item 6)

Personnel Required

Petroleum Supply Specialist 92F

NOTE

Operator repair of Tank/Berm Liner Ball Valve Assembly is limited to replacement of defective gaskets.

REMOVAL OF TANK/BERM LINER DRAIN BALL VALVE GASKET

1. Pull cam-lever arms (Figure 1, Item 1) on Dust Cap (Figure 1, Item 2) out, away from body of Dust Cap (Figure 1, Item 2).
2. Remove Dust Cap (Figure 1, Item 2) from Male Coupling (Figure 1, Item 3).
3. Remove and discard Gasket (Figure 1, Item 4) from Dust Cap (Figure 1, Item 2).
4. Pull cam-lever arms (Figure 1, Item 5) on Female Coupling (Figure 1, Item 6) out, away from body of Female Coupling (Figure 1, Item 6).
5. Remove Dust Plug (Figure 1, Item 7) from Female Coupling (Figure 1, Item 6).
6. Remove and discard Gasket (Figure 1, Item 8) from Female Coupling (Figure 1, Item 6).

END OF TASK

Figure 1. Tank/Berm Liner Ball Valve Assembly.

INSTALLATION OF TANK/BERM LINER DRAIN BALL VALVE GASKET

1. Install new Gasket (Figure 1, Item 8) on Female Coupling (Figure 1, Item 6).
2. Push cam-lever arms (Figure 1, Item 5) on Female Coupling (Figure 1, Item 6) outward, away from body of Female Coupling (Figure 1, Item 6).
3. Install Dust Plug (Figure 1, Item 7) in Female Coupling (Figure 1, Item 6).
4. Push cam-lever arms (Figure 1, Item 5) on Female Coupling (Figure 1, Item 6) inward toward body of Female Coupling (Figure 1, Item 6) until locked.
5. Install new Gasket (Figure 1, Item 4) on Dust Cap (Figure 1, Item 2).
6. Push cam-lever arms (Figure 1, Item 1) on Dust Cap (Figure 1, Item 2) outward, away from body of Dust Cap (Figure 1, Item 2).
7. Install Dust Cap (Figure 1, Item 2) on Male Coupling (Figure 1, Item 3).
8. Push cam-lever arms (Figure 1, Item 1) on Dust Cap (Figure 1, Item 2) inward toward body of Dust Cap (Figure 1, Item 2) until locked.

END OF TASK**END OF WORK PACKAGE**

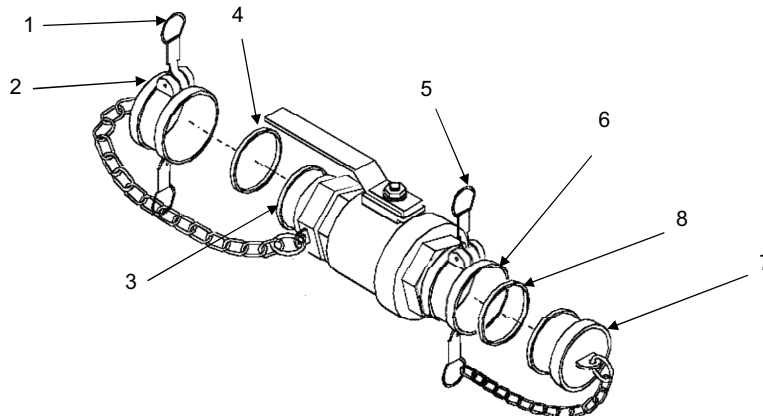
**OPERATOR MAINTENANCE
VENT PORT ASSEMBLY
REPAIR**

INITIAL SETUP:**Materials/Parts**

Gasket (2) (WP 0076, Item 4)

Equipment Condition

Tank Envelope empty, on level surface

Personnel Required

Petroleum Supply Specialist 92F

NOTE

Operator repair of Vent Port Assembly is limited to replacement of Gaskets.

REMOVAL OF VENT PORT ASSEMBLY COUPLING HALF AND GASKET

1. Disconnect Coupling Half (Figure 1, Item 1) from Flanged Adapter (Figure 1, Item 2) by pulling outward on cam-lever arms (Figure 1, Item 3).
2. Lift Coupling Half (Figure 1, Item 1) from Flanged Adapter (Figure 1, Item 2).
3. Remove Coupling Half Gasket (Figure 1, Item 4). Discard Gasket (Figure 1, Item 4).
4. Remove Gasket (Figure 1, Item 5) from inside Dust Cap (Figure 1, Item 6). Discard Gasket (Figure 1, Item 5).

END OF TASK**NOTE**

Vent Port, Vent Cap, and Flame Arrestor removed for clarity.

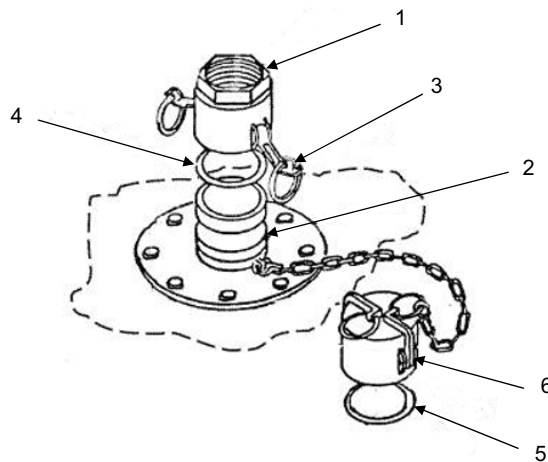

Figure 1. Vent Port Assembly.

INSTALLATION OF VENT PORT ASSEMBLY COUPLING HALF AND GASKET

1. Seat new Gasket (Figure 1, Item 4) into Coupling Half (Figure 1, Item 1).
2. With cam-lever arms (Figure 1, Item 3) in the outward position, install Coupling Half (Figure 1, Item 1) to Flanged Adapter (Figure 1, Item 2).
3. Push cam-lever arms (Figure 1, Item 3) inward until they lock in place.
4. Seat new Gasket (Figure 1, Item 5) into Dust Cap (Figure 1, Item 6).

END OF TASK**END OF WORK PACKAGE**

**OPERATOR MAINTENANCE
FILLER/DISCHARGE ASSEMBLY
REPAIR**

INITIAL SETUP:**Materials/Parts**

Gasket (2) (WP 0076, Item 3)

Personnel Required

Petroleum Supply Specialist 92F

NOTE

Operator repair of Filler/Discharge Assembly is limited to replacement of defective gaskets.

REMOVAL OF FILLER/DISCHARGE GASKETS

1. Remove Filler/Discharge Elbow (Figure 1, Item 1) or Dust Cap (Figure 1, Item 2) by pulling outward on cam-lever arms (Figure 1, Item 3), and lifting Filler/Discharge Elbow (Figure 1, Item 1) or Dust Cap (Figure 1, Item 2) from Flanged Adapter (Figure 1, Item 4).

NOTE

Filler Elbow has two Gaskets.

2. Remove Gasket (Figure 1, Item 5) from Filler/Discharge Elbow (Figure 1, Item 1) and Gasket (Figure 1, Item 6) from Dust Cap (Figure 1, Item 2). Discard Gaskets (Figure 1, Items 5 and 6).

END OF TASK

Figure 1. Filler/Discharge Assembly.

INSTALLATION OF FILLER/DISCHARGE GASKETS**NOTE**

Filler Elbow requires two new Gaskets.

1. Place new Gasket (Figure 1, Item 5) into Filler/Discharge Elbow (Figure 1, Item 1) and new Gasket (Figure 1, Item 6) in Dust Cap (Figure 1, Item 2).
2. Install Filler/Discharge Elbow (Figure 1, Item 1) onto Flanged Adapter (Figure 1, Item 4), by pushing inward on cam-lever arms (Figure 1, Item 3) to lock Filler/Discharge Elbow (Figure 1, Item 1) into position.
3. Install Dust Cap (Figure 1, Item 2) onto Filler/Discharge Elbow (Figure 1, Item 1) by pushing inward on cam-lever arms (Figure 1, Item 3) on Dust Cap (Figure 1, Item 2) to lock into position.

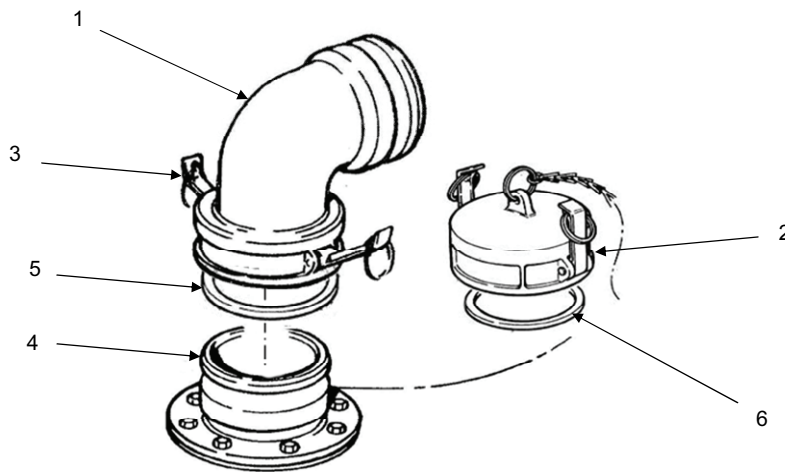
END OF TASK

END OF WORK PACKAGE

CHAPTER 5

**FIELD MAINTENANCE TROUBLESHOOTING PROCEDURES
FOR
TANK, FABRIC, COLLAPSIBLE, FUEL STORAGE,
20,000 GALLON**

**FIELD MAINTENANCE
MASTER MALFUNCTION/SYMPTOM INDEX**

MALFUNCTION/SYMPTOM

TROUBLESHOOTING PROCEDURE

GENERAL

- 1. Shutoff Valve from Fuel Source Host System WP 0027
- 2. Filler/Discharge Hose Assembly WP 0028
- 3. Tank or Berm Liner Drain Ball Valve Assembly WP 0029
- 4. Tank Drain Hose Assembly WP 0030
- 5. Vent Port Assembly WP 0031
- 6. Cap and Flame Arrestor Assembly, Passive Vent..... WP 0032
- 7. Filler/Discharge Assembly WP 0033
- 8. Tank Drain Fitting Assembly WP 0034
- 9. Berm Liner Drain Fitting Assembly..... WP 0035
- 10. Berm Liner Drain Hose Assembly, Bowl x Cam and Cam x Cam WP 0036

END OF TASK

END OF WORK PACKAGE

**FIELD MAINTENANCE
SHUTOFF VALVE FROM FUEL SOURCE HOST SYSTEM
TROUBLESHOOTING PROCEDURES**

INITIAL SETUP:**Personnel Required**

Quartermaster and Chemical Equipment
Repairer 63J

TROUBLESHOOTING PROCEDURES**SHUTOFF VALVE FROM FUEL SOURCE HOST SYSTEM****WARNING**

Fuel vapors are extremely flammable. Exercise care to prevent sparks when working near Tank Assembly. Death or severe personal injury can result if safety precautions are not strictly observed.

SYMPTOM

Female Coupling leaks.

MALFUNCTION

Check Female Coupling for cracks or bent or missing cam-lever arms.

CORRECTIVE ACTION

Replace Female Coupling if cam-lever arms are damaged or missing. (Refer to appropriate Class III system technical manual for repair procedures).

END OF WORK PACKAGE

**FIELD MAINTENANCE
FILLER/DISCHARGE HOSE ASSEMBLY
TROUBLESHOOTING PROCEDURES**

INITIAL SETUP:**Personnel Required**

Quartermaster and Chemical Equipment
Repairer 63J

References

WP 0040

TROUBLESHOOTING PROCEDURES**FILLER/DISCHARGE HOSE ASSEMBLY****WARNING**

Fuel vapors are extremely flammable. Exercise care to prevent sparks when working near Tank Assembly. Death or severe personal injury can result if safety precautions are not strictly observed.

SYMPTOM

Filler/Discharge Hose Assembly couplings leak.

MALFUNCTION

Filler/Discharge Hose Assembly leaks or is torn.

CORRECTIVE ACTION

Service Filler/Discharge Hose Assembly (WP 0040).

END OF WORK PACKAGE

**FIELD MAINTENANCE
TANK OR BERM LINER DRAIN BALL VALVE ASSEMBLY
TROUBLESHOOTING PROCEDURES**

INITIAL SETUP:**Personnel Required**

Quartermaster and Chemical Equipment
Repairer 63J

References

WP 0041

TROUBLESHOOTING PROCEDURES**TANK OR BERM LINER DRAIN BALL VALVE****WARNING**

Fuel vapors are extremely flammable. Exercise care to prevent sparks when working near Tank Assembly. Death or severe personal injury can result if safety precautions are not strictly observed.

SYMPTOM

Drain Valve leaks.

MALFUNCTION

Drain Valve is damaged or worn.

CORRECTIVE ACTION

Service, replace, or repair Drain Valve (WP 0041).

END OF WORK PACKAGE

**FIELD MAINTENANCE
TANK DRAIN HOSE ASSEMBLY
TROUBLESHOOTING PROCEDURES**

INITIAL SETUP:**Personnel Required**

Quartermaster and Chemical Equipment
Repairer 63J

References

WP 0042
WP 0043

TROUBLESHOOTING PROCEDURES**TANK DRAIN HOSE ASSEMBLY****WARNING**

Fuel vapors are extremely flammable. Exercise care to prevent sparks when working near Tank Assembly. Death or severe personal injury can result if safety precautions are not strictly observed.

SYMPTOM

Tank Drain Hose Assembly does not drain properly.

MALFUNCTION

Tank Drain Hose Assembly is worn, cracked or clogged with dirt or grime.

CORRECTIVE ACTION

Service Tank Drain Hose Assembly (WP 0042) and (WP 0043).

END OF WORK PACKAGE

**FIELD MAINTENANCE
VENT PORT ASSEMBLY
TROUBLESHOOTING PROCEDURES**

INITIAL SETUP:**Personnel Required**

Quartermaster and Chemical Equipment
Repairer 63J

References

WP 0044

TROUBLESHOOTING PROCEDURES**VENT PORT ASSEMBLY****WARNING**

Fuel vapors are extremely flammable. Exercise care to prevent sparks when working near Tank Assembly. Death or severe personal injury can result if safety precautions are not strictly observed.

SYMPTOM

Vent Pipe leaks.

MALFUNCTION

Vent Pipe Gasket is cracked, distorted or worn.

CORRECTIVE ACTION

Service, repair, or replace Gasket (WP 0044).

MALFUNCTION

Vent Pipe is cracked, bent, or damaged.

CORRECTIVE ACTION

Replace Vent Pipe (WP 0044).

MALFUNCTION

Gasket between Coupling Half and Flanged Adapter is damaged.

CORRECTIVE ACTION

Replace Gasket.

MALFUNCTION

Flanged Adapter is cracked or broken.

CORRECTIVE ACTION

Replace Flanged Adapter (WP 0044).

VENT PORT ASSEMBLY – CONTINUED

MALFUNCTION

Screws or Washers are loose or missing.

CORRECTIVE ACTION

Replace Screws and Washers (WP 0044).

END OF WORK PACKAGE

**FIELD MAINTENANCE
CAP AND FLAME ARRESTOR ASSEMBLY, PASSIVE VENT
TROUBLESHOOTING PROCEDURES**

INITIAL SETUP:**Personnel Required**

Quartermaster and Chemical Equipment
Repairer 63J

References

WP 0044

TROUBLESHOOTING PROCEDURES**VENT CAP AND FLAME ARRESTOR****WARNING**

Fuel vapors are extremely flammable. Exercise care to prevent sparks when working near Tank Assembly. Death or severe personal injury can result if safety precautions are not strictly observed.

SYMPTOM

Vent Cap leaks.

MALFUNCTION

Vent Cap leaks.

CORRECTIVE ACTION

Replace Vent Cap Gasket (WP 0044).

SYMPTOM

Flame Arrestor does not work properly.

MALFUNCTION

Flame Arrestor is cracked, broken, or worn.

CORRECTIVE ACTION

Service, repair, or replace Flame Arrestor (WP 0044).

END OF WORK PACKAGE

**FIELD MAINTENANCE
FILLER/DISCHARGE ASSEMBLY
TROUBLESHOOTING PROCEDURES**

INITIAL SETUP:**Personnel Required**

Quartermaster and Chemical Equipment
Repairer 63J

References

WP 0045

TROUBLESHOOTING PROCEDURES**FILLER/DISCHARGE ASSEMBLY****WARNING**

Fuel vapors are extremely flammable. Exercise care to prevent sparks when working near Tank Assembly. Death or severe personal injury can result if safety precautions are not strictly observed.

SYMPTOM

Filler/Discharge Assembly leaks between Compression Plate and Tank Envelope fitting.

MALFUNCTION

Washers or Screws are missing or loose.

CORRECTIVE ACTION

Replace Washers and Screws (WP 0045).

MALFUNCTION

O-ring between Compression Plate and Tank Envelope fitting is nicked, broken, or compressed.

CORRECTIVE ACTION

Replace O-ring (WP 0045).

SYMPTOM

Filler/Discharge Assembly leaks between Compression Plate and Flanged Adapter.

MALFUNCTION

Nuts, Lock Washers, Gaskets, or Screws are missing or loose.

CORRECTIVE ACTION

Replace missing hardware (WP 0045).

FILLER/DISCHARGE ASSEMBLY – CONTINUED**MALFUNCTION**

Flanged Adapter Gasket is damaged or worn.

CORRECTIVE ACTION

Remove Flanged Adapter from Compression Plate and replace damaged Gasket (WP 0045).

SYMPTOM

Filler/Discharge Assembly leaks through hardware or will not assemble.

MALFUNCTION

Filler/Discharge fastening hardware is cracked, damaged, or worn.

CORRECTIVE ACTION

Replace fastening hardware (WP 0045).

SYMPTOM

Filler/Discharge Elbows leak.

MALFUNCTION

Filler/Discharge Elbows are cracked, dented, or worn, or Gaskets are damaged or missing.

CORRECTIVE ACTION

Replace damaged Filler/Discharge Elbows and Gaskets (WP 0045).

END OF WORK PACKAGE

**FIELD MAINTENANCE
TANK DRAIN FITTING ASSEMBLY
TROUBLESHOOTING PROCEDURES**

INITIAL SETUP:**Personnel Required**

Quartermaster and Chemical Equipment
Repairer 63J

References

WP 0046

TROUBLESHOOTING PROCEDURES**TANK DRAIN FITTING ASSEMBLY****WARNING**

Fuel vapors are extremely flammable. Exercise care to prevent sparks when working near Tank Assembly. Death or severe personal injury can result if safety precautions are not strictly observed.

SYMPTOM

Tank Drain Fitting Assembly leaks between Blind Flange Cover and Tank Envelope.

MALFUNCTION

Washers or Screws are loose or missing.

CORRECTIVE ACTION

Replace Washers and Screws (WP 0046).

MALFUNCTION

Gasket between the Blind Flange Cover and Tank Envelope drain port is nicked, broken, or compressed.

CORRECTIVE ACTION

Replace Gasket (WP 0046).

SYMPTOM

Tank Drain Fitting Assembly leaks through metal.

MALFUNCTION

Blind Flange Cover is damaged or cracked.

CORRECTIVE ACTION

Replace Blind Flange Cover (WP 0046).

END OF WORK PACKAGE

**FIELD MAINTENANCE
BERM LINER DRAIN FITTING ASSEMBLY
TROUBLESHOOTING PROCEDURES**

INITIAL SETUP:**Personnel Required**

Quartermaster and Chemical Equipment
Repairer 63J

References

WP 0048

TROUBLESHOOTING PROCEDURES**BERM LINER DRAIN FITTING ASSEMBLY****WARNING**

Fuel vapors are extremely flammable. Exercise care to prevent sparks when working near Tank Assembly. Death or severe personal injury can result if safety precautions are not strictly observed.

SYMPTOM

Berm Liner Drain Fitting Assembly leaks between Blind Flange Cover and Berm Liner.

MALFUNCTION

Washers or Screws are loose or missing.

CORRECTIVE ACTION

1. Replace Screws and Washers (WP 0048).
2. Check Berm Liner Drain Fitting Assembly for nicks, breaks, and compression (WP 0048).
3. Replace Berm Liner Drain Fitting Assembly Gaskets (WP 0048).

END OF WORK PACKAGE

**FIELD MAINTENANCE
BERM LINER DRAIN HOSE ASSEMBLY, BOWL x CAM AND CAM x CAM
TROUBLESHOOTING PROCEDURES**

INITIAL SETUP:**Personnel Required**

Quartermaster and Chemical Equipment
Repairer 63J

References

WP 0049
WP 0050

TROUBLESHOOTING PROCEDURES**BERM LINER DRAIN HOSE ASSEMBLY, BOWL x CAM AND CAM x CAM****WARNING**

Fuel vapors are extremely flammable. Exercise care to prevent sparks when working near Tank Assembly. Death or severe personal injury can result if safety precautions are not strictly observed.

SYMPTOM

Berm Liner Drain Hose Assembly does not drain properly.

MALFUNCTION

Berm Liner Drain Hose is cracked, worn, or clogged with dirt or grime.

CORRECTIVE ACTION

Service Berm Liner Drain Hose (WP 0049 and WP 0050).

END OF WORK PACKAGE

CHAPTER 6

**FIELD MAINTENANCE INSTRUCTIONS
FOR
TANK, FABRIC, COLLAPSIBLE, FUEL STORAGE,
20,000 GALLON**

**FIELD MAINTENANCE
SERVICE UPON RECEIPT OF MATERIAL**

INITIAL SETUP:**Tools and Special Tools**

Tool kit, general mechanic's (WP 0073, Item 1)

References

DA PAM 750-8
SF 361

Personnel Required

Petroleum Supply Specialist 92F
Quartermaster and Chemical Equipment
Repairer 63J

GENERAL INFORMATION

The following paragraphs contain the procedures for unloading, and general checking of the unpacked Tank Assembly.

Inspect the equipment for damage incurred during shipment. If the equipment has been damaged, report the damage on SF 361, Transportation Discrepancy Report.

Check equipment against the packing slip to ensure that the shipment is complete. Report all discrepancies in accordance with applicable service instructions, DA PAM 750-8.

CAUTION

The Tank Assembly should be installed on a level area free of debris and large rocks. Special care should be taken to ensure that no hose assemblies will be placed on or near rocks or other objects that may have sharp points or edges that can damage the hose assemblies when the fuel system is operated. Be sure that the site allows for enough room to assemble the fuel system.

SERVICE UPON RECEIPT OF MATERIEL

Inspect the equipment for damage incurred (punctures or tears) during shipment. If the equipment has been damaged, report the damage in accordance with the instructions of DA PAM 750-8.

Check the equipment against the packing slip to see if the shipment is complete. Report all discrepancies in accordance with the instructions of DA PAM 750-8.

Inspect Emergency Repair Kit (Mechanical Patches and Wood Plugs) that are packaged separately. Place the items in a secure storage area until required.

Check to see whether the equipment has been modified.

If a special design reusable container is used for components that are authorized for replacements, instructions shall be prepared to report or return the empty container through supply channels. Instructions shall be prepared on how to package the unserviceable component in the empty container in the same manner that the new component was packaged if a component is being replaced.

UNPACKING

Unpack Tank Assembly and refer to shipping documents.

CHECK UNPACKED EQUIPMENT

Table 1. Equipment Inspection.

COMPONENT	ACCEPTABLE	REPAIRABLE	NONREPARABLE
TANK ASSEMBLY COMPONENTS			
Tank Assembly	Free from major damage. NOTE Air pockets trapped between Tank Envelope and interior chafing patches sometimes occur during manufacturing. This does not affect the functionality of the Tank Assembly.	Any damage that does not affect serviceability of Tank Assembly.	Major damage that affects the serviceability.
Couplings	Minor or corrosion that would not impair serviceability of the couplings.	Minor rust or corrosion that can be removed without affecting serviceability of the couplings.	Rust, damage or corrosion that affects serviceability of couplings.
Valve Assemblies	Minor rust or corrosion that would not impair serviceability or the valve assemblies.	Minor rust or corrosion that can be removed without affecting the serviceability of valve assemblies.	Rust, damage or corrosion that affects serviceability of valve assemblies.
Hoses	Free of rips and tears.	N/A	Small pinholes, major rip or tears.

PRELIMINARY SERVICING OF EQUIPMENT

No preliminary servicing or adjustment is required.

END OF TASK**END OF WORK PACKAGE**

**FIELD MAINTENANCE
PREVENTIVE MAINTENANCE CHECKS AND SERVICES (PMCS)
INTRODUCTION**

INTRODUCTION**GENERAL**

Systematic, periodic, Preventive Maintenance Checks and Services (PMCS) are essential to ensure that the Tank Assembly is ready for operation at all times. The purpose of a preventive maintenance program is to discover and correct defects and deficiencies before they can cause serious damage or complete failure of the equipment. Any effective preventive maintenance program must begin with the indoctrination of Operators to report all unusual conditions noted during daily checks or actual operation to Field Maintenance. All defects and deficiencies discovered during maintenance inspections must be recorded, together with corrective action taken, on DA Form 2404 (Equipment Inspection and Maintenance Worksheet), or DA Form 5988-E (Equipment Maintenance and Inspection Worksheet). Pay attention to WARNING and CAUTION statements. A WARNING means someone could be injured or killed. A CAUTION means equipment could get damaged.

A schedule for Field Maintenance inspection and service should be established immediately after initial operation of the Tank Assembly. When operating under unusual conditions, such as a very dusty or sandy environment, it may be necessary to reduce the interval to monthly or even less if conditions are extreme.

WARNING

Severe injury or death can occur from fire and explosion caused by fuel and fuel fumes.
NEVER allow open flames or objects to get near the Tank Assembly after storing fuel.

If you find something wrong when performing PMCS, fix it, if you can, using troubleshooting procedures and/or maintenance procedures.

The right-hand column of the PMCS table lists conditions that make the equipment not fully mission capable. Write up items not fixed on DA Form 2404 or DA Form 5988-E for Field Maintenance. For further information on how to use these forms, see DA PAM 750-8.

LEAKAGE DEFINITIONS**CAUTION**

Equipment operation is allowed with minor leakage (Class I or II).

When operating with Class I or II leaks, continue to check drip pans and ensure the leak is not a Class III leak.

If there is a Class III leak, shut down operation immediately, and report it to your supervisor.

It is important to understand how fluid leakage affects the status of the tank. Following are definitions of the leakage classes the operator and mechanic need to become familiar with in order to be able to determine the condition of the leak. Remember, when in doubt, always consult your supervisor.

Leakage Classifications for PMCS:

CLASS I - Seepage of fluid (as indicated by wetness or discoloration) not great enough to form drops.

CLASS II - Leakage of fluid great enough to form drops but not enough to cause drops to drip from item being inspected.

LEAKAGE DEFINITIONS – CONTINUED

CLASS III - Leakage of fluid great enough to form drops that fall from the item being inspected.

INSPECTION

Look for signs of a problem or trouble. You can feel, smell, hear or see many problems. Be alert when using the equipment.

Inspect to ensure items are in good condition. Are they correctly assembled, stowed, secured, excessively worn, leaking, corroded or properly lubricated? Correct any problems found.

The following are common items to check throughout the equipment:

1. Bolts, clamps, nuts and Screws: Continually check for looseness. Look for chipped paint, bare metal, rust or corrosion around bolt and Screw heads and nuts; tighten when loose.
2. Hoses and fluid lines: Look for wear, damage and leaks. Ensure that clamps and fittings are tight. Wet spots indicate leakage. A stain near a fitting or connector can also indicate leakage. If a leak is discovered, repair as required.

CORROSION PREVENTION AND CONTROL (CPC)

Corrosion Prevention and Control (CPC) of Army materiel is a continuing concern. It is important that any corrosion problems with this item be reported so corrections and improvements can be made to prevent problems in future items.

Corrosion is typically associated with rusting of metals or galvanic corrosion, which produces a white powder. Corrosion also includes deterioration of other materials, such as rubber and plastic. Unusual cracking, softening, swelling or breaking of the materials may indicate corrosion problems. If a corrosion problem is identified, it can be reported using SF 368 Product Quality Deficiency Report. Use of key words, such as "corrosion," "rust," "deterioration," or "cracking," will ensure that the information is identified as a CPC problem. The form should be submitted to the address specified in DA PAM 750-8.

ARMY OIL ANALYSIS PROGRAM (AOAP)

This Tank Assembly is not enrolled in the Army Oil Analysis Program.

END OF TASK

END OF WORK PACKAGE

**FIELD MAINTENANCE
PREVENTIVE MAINTENANCE CHECKS AND SERVICES (PMCS) AND
LUBRICATION PROCEDURES**

INITIAL SETUP:

Tools and Special Tools

Tool kit, general mechanic's (WP 0073, Item 1)

References

WP 0002
WP 0004

Personnel Required

Quartermaster and Chemical Equipment
Repairer 63J

PMCS AND LUBRICATION PROCEDURES

NOTE

Refer to WP 0002 and WP 0004 for location of components.

Table 1. Preventive Maintenance Checks and Services (PMCS).

ITEM NO.	INTERVAL	ITEM TO BE CHECKED OR SERVICED	PROCEDURE	EQUIPMENT NOT READY/ AVAILABLE IF:
1	Quarterly	Tank Envelope	Inspect for cuts, punctures and leaks. Loose or missing bolts where fittings connect to Tank Envelope.	Tank Envelope is cut, punctured or leaks. Loose or missing bolts.
2	Quarterly	Shutoff valve from fuel source host system	<ol style="list-style-type: none"> 1. Check for proper operation and leakage. 2. Check for bent, broken, or binding parts. 	Filler/Discharge Ball Valve will not open/close and/or is leaking. Parts are missing or damaged.
3	Quarterly	Vent Port Assembly	<ol style="list-style-type: none"> 1. Inspect for evidence of leakage. 2. Check the Vent Cap for cleanliness. 3. Check Vent Cap and cam-lever arms are not damaged or missing. 	Any evidence of leakage. Vent Cap missing or cam-lever arms are damaged or missing.

PMCS AND LUBRICATION PROCEDURES – CONTINUED

Table 1. Preventive Maintenance Checks and Services (PMCS) – Continued.

ITEM NO.	INTERVAL	ITEM TO BE CHECKED OR SERVICED	PROCEDURE	EQUIPMENT NOT READY/ AVAILABLE IF:
4	Quarterly	Filler/Discharge Elbow	<ol style="list-style-type: none"> 1. Check for evidence of damage. 2. Check if cam-lever arms are damaged or missing. 3. Check if the elbow body is cracked or sealing surface is badly dented. 4. Check for loose, damaged or missing Screws and Gaskets. 	<p>Evidence of damage.</p> <p>Cam-lever arms are damaged or missing.</p> <p>Filler/Discharge Elbow or sealing surface is badly dented or cracked.</p> <p>Hardware is loose, damaged or missing Screws or Gaskets.</p>
5	Quarterly	Filler/Discharge Hose	<ol style="list-style-type: none"> 1. Check for evidence of damage. 2. Check if cam-lever arms are damaged or missing. 3. Check if couplings, Dust Plug, or Dust Cap is cracked or sealing surface is badly dented. 4. Check for loose, damaged or missing hardware. 	<p>Evidence of damage.</p> <p>Cam-lever arms are damaged or missing.</p> <p>Couplings, Dust Plug, or Dust Cap is cracked or sealing surface is badly dented.</p> <p>Hardware is damaged or missing.</p>
6	Quarterly	Tank Drain	Inspect for damaged or missing hardware.	Damaged or missing hardware.
7	Quarterly	Emergency Repair Kit	Check for missing components.	
8	Quarterly	Berm Liner Assembly	<ol style="list-style-type: none"> 1. Check Berm Liner Drain Hose Assembly, Berm Liner Bowl Fitting, and Berm Liner Drain Ball Valve for damaged or missing parts. 2. Inspect for missing Gaskets or damaged cam-lever arms. 	<p>Berm Liner Drain Hose Assembly, Berm Liner Bowl Fitting, or Berm Liner Drain Ball Valve damaged or missing parts.</p> <p>Gaskets missing or damaged cam-lever arms.</p>

Lubrication Procedures

No lubrication required for this equipment.

END OF WORK PACKAGE

**FIELD MAINTENANCE
FILLER/DISCHARGE HOSE ASSEMBLY
SERVICE AND REPAIR**

INITIAL SETUP:**Tools and Special Tools**

Tool kit, general mechanic's (WP 0073, Item 1)

Personnel Required

Quartermaster and Chemical Equipment
Repairer 63J

Materials/Parts

Detergent, general purpose (WP 0075, Item 2)
Gasket (2) (WP 0076, Item 2)

DISASSEMBLY

1. Pull outward on two cam-lever arms (Figure 1, Item 3).
2. Remove Dust Cap (Figure 1, Item 4) from Male Coupling (Figure 1, item 7).
3. Remove Gasket (Figure 1, Item 2) from Dust Cap (Figure 1, Item 4). Discard Gasket.
4. Remove Chain (Figure 1, Item 6) and two Key Holders (Figure 1, Item 5) from Dust Cap (Figure 1, Item 4) and Male Coupling (Figure 1, item 7).
5. Pull outward on two cam-lever arms (Figure 1, Item 8).
6. Remove Dust Plug (Figure 1, Item 12) from Female Coupling (Figure 1, Item 9).
7. Remove Chain (Figure 1, Item 10) and two Key Holders (Figure 1, Item 11) from Dust Plug (Figure 1, Item 12) and Female Coupling (Figure 1, Item 9).
8. Remove Gasket (Figure 1, Item 13) in Female Coupling (Figure 1, Item 9). Discard Gasket.

END OF TASK

SERVICE

1. Flush out the Filler/Discharge Hose Assembly (Figure 1, Item 1), with soapy water.
2. Rinse out the Filler/Discharge Hose Assembly (Figure 1, Item 1), thoroughly and air-dry.
3. Inspect the Filler/Discharge Hose Assembly (Figure 1, Item 1) for cracks, tears, or wear, and ensure that the hose bands are securely fastened to the couplings.
4. Inspect all mechanical parts for cracks, dents, breaks and wear. Replace any unserviceable components.

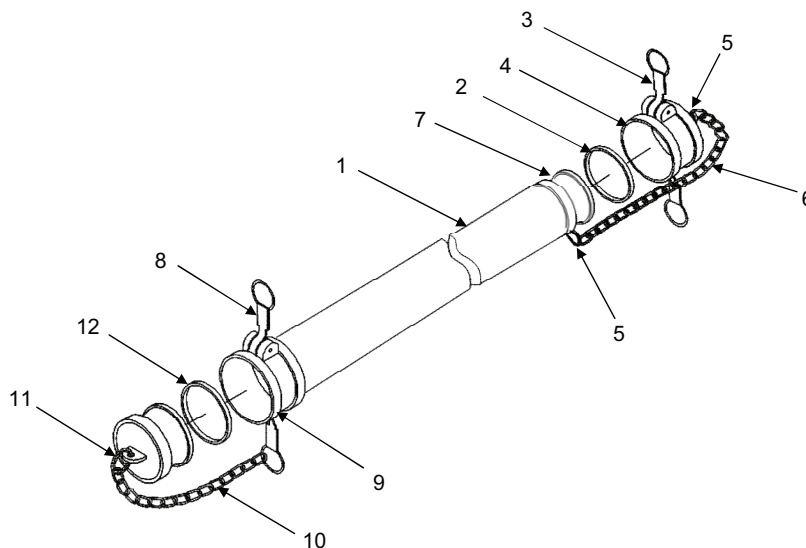

Figure 1. Filler/Discharge Hose Assembly.

END OF TASK

ASSEMBLY

1. Install Chain (Figure 1, Item 10) and two Key Holders (Figure 1, Item 11) on Dust Plug (Figure 1, Item 12) and Female Coupling (Figure 1, Item 9).
2. Install new Gasket (Figure 1, Item 13) in Female Coupling (Figure 1, Item 9).
3. Push cam-lever arms (Figure 1, Item 8) on Female Coupling (Figure 1, Item 9) outward, away from body of Female Coupling (Figure 1, Item 9).
4. Install Dust Plug (Figure 1, Item 12) in Female Coupling (Figure 1, Item 9).
5. Push cam-lever arms (Figure 1, Item 8) on Female Coupling (Figure 1, Item 9) inward, toward body of Female Coupling (Figure 1, Item 9) until locked.
6. Install Chain (Figure 1, Item 6) and two Key Holders (Figure 1, Item 5) on Dust Cap (Figure 1, Item 4) and Male Coupling (Figure 1, Item 7).
7. Install new Gasket (Figure 1, Item 2) in Dust Cap (Figure 1, Item 4).
8. Push cam-lever arms (Figure 1, Item 3) on Dust Cap (Figure 1, Item 4) outward, away from body of Dust Cap (Figure 1, Item 4).

ASSEMBLY – CONTINUED

9. Install Dust Cap (Figure 1, Item 3) on Male Coupling (Figure 1, Item 7).
10. Push cam-lever arms (Figure 1, Item 3) on Dust Cap (Figure 1, Item 4) inward, toward body of Dust Cap (Figure 1, Item 4) until locked.

END OF TASK**END OF WORK PACKAGE**

**FIELD MAINTENANCE
TANK OR BERM LINER DRAIN BALL VALVE ASSEMBLY
SERVICE AND REPAIR**

INITIAL SETUP:**Tools and Special Tools**

Tool kit, general mechanic's (WP 0073, Item 1)

Personnel Required

Quartermaster and Chemical Equipment Repairer 63J

Materials/Parts

Dry cleaning solvent (WP 0075, Item 3)
Gasket (2) (WP 0076, Item 2)
Gloves, chemical and oil protective (WP 0075, Item 4)
Goggles, industrial (WP 0075, Item 5)
Rag, wiping (WP 0075, Item 6)
Sealing compound (WP 0075, Item 7)
Tape, anti-seizing (WP 0075, Item 9)

Equipment Condition

Tank Envelope drained (WP 0005)

REMOVAL

Remove the drain ball valve.

END OF TASK**DISASSEMBLY**

1. Pull cam-lever arms (Figure 1, Item 1) on Dust Cap (Figure 1, Item 2) out, away from body of Dust Cap (Figure 1, Item 2).

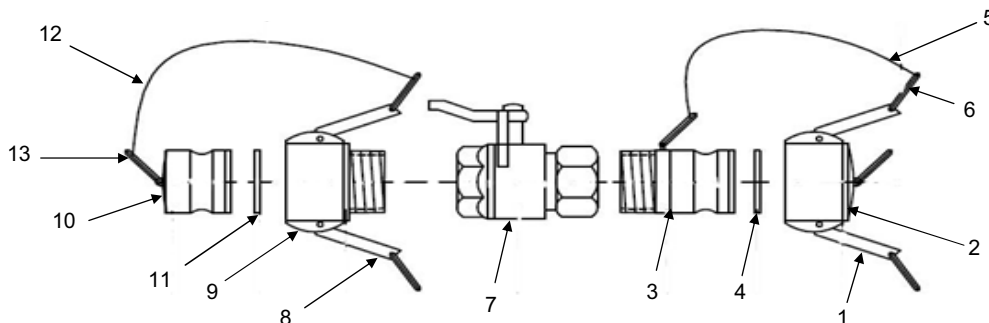

Figure 1. Tank or Berm Liner Drain Valve.

2. Remove Dust Cap (Figure 1, Item 2) from Male Coupling (Figure 1, Item 3). Remove Gasket (Figure 1, Item 4) from Dust Cap (Figure 1, Item 2). Discard Gasket.
3. Disconnect Chain (Figure 1, Item 5) and two Key Holders (Figure 1, Item 6) from Dust Cap (Figure 1, Item 2) and Male Coupling (Figure 1, Item 3).
4. Unscrew Male Coupling (Figure 1, Item 3) from Tank or Berm Liner Drain Valve (Figure 1, Item 7).
5. Pull cam-lever arms (Figure 1, Item 8) on Female Coupling (Figure 1, Item 9) out, away from body of Female Coupling (Figure 1, Item 9).

DISASSEMBLY – CONTINUED

6. Remove Dust Plug (Figure 1, Item 10) from Female Coupling (Figure 1, Item 9). Remove Gasket (Figure 1, Item 11) from Female Coupling (Figure 1, Item 9). Discard Gasket.
7. Disconnect Chain (Figure 1, Item 12) and two Key Holders (Figure 1, Item 13) from Dust Plug (Figure 1, Item 10) and Female Coupling (Figure 1, Item 9).
8. Unscrew Female Coupling (Figure 1, Item 9) from Tank or Berm Liner Drain Valve (Figure 1, Item 7).

END OF TASK**SERVICE****WARNING**

Dry cleaning solvent, A-A-59601, used to clean parts, is potentially dangerous to personnel. It produces toxic and flammable fumes. Use only in well ventilated areas. Avoid repeated and prolonged skin contact. Wear protective rubber gloves and chemical splash goggles. Do not use solvent near an open flame or near excessive heat. The flash point of the solvent is 100°F to 130°F (38°C to 54°C). Failure to comply with this warning may result in serious injury or death to personnel.

CAUTION

Dry cleaning solvent, A-A-59601, used to clean parts, must not come into contact with any part of the Tank Envelope fabric. Damage to fabric will occur.

1. Clean all parts with dry cleaning solvent (WP 0075, Item 3) and dry thoroughly with wiping rags (WP 0075, Item 6).
2. Inspect all mechanical parts for cracks, dents, breaks, and wear.
3. Replace the component if unserviceable.

END OF TASK**ASSEMBLY**

1. Coat threads of Female Coupling (Figure 1, Item 9) with a thread sealing compound (WP 0075, Item 7) or anti-seizing tape (WP 0075, Item 9), and install Female Coupling (Figure 1, Item 9) in Tank or Berm Liner Drain Valve (Figure 1, Item 7).
2. Connect Chain (Figure 1, Item 12) and two Key Holders (Figure 1, Item 13) to Dust Plug (Figure 1, Item 10) and Female Coupling (Figure 1, Item 9).
3. Install new Gasket (Figure 1, Item 11) on Female Coupling (Figure 1, Item 9).
4. Push cam-lever arms (Figure 1, Item 8) on Female Coupling (Figure 1, Item 9) outward, away from body of Female Coupling (Figure 1, Item 9).
5. Install Dust Plug (Figure 1, Item 10) in Female Coupling (Figure 1, Item 9).
6. Push cam-lever arms (Figure 1, Item 8) on Female Coupling (Figure 1, Item 9) inward, toward body of Female Coupling (Figure 1, Item 9) until locked.
7. Coat threads of Male Coupling (Figure 1, Item 3) with a thread sealing compound (WP 0075, Item 7) or anti-seizing tape (WP 0075, Item 9), and install Male Coupling (Figure 1, Item 3) in Tank or Berm Liner Drain Valve (Figure 1, Item 7).
8. Connect Chain (Figure 1, Item 5) and two Key Holders (Figure 1, Item 6) to Male Coupling (Figure 1, Item 3) and Dust Cap (Figure 1, Item 2).

ASSEMBLY – CONTINUED

9. Push cam-lever arms (Figure 1, Item 1) on Dust Cap (Figure 1, Item 2) outward, away from body of Dust Cap (Figure 1, Item 2).
10. Install Dust Cap (Figure 1, Item 2) on Male Coupling (Figure 1, Item 3).
11. Push cam-lever arms (Figure 1, Item 1) on Dust Cap (Figure 1, Item 2) inward, toward body of Dust Cap (Figure 1, Item 2) until locked.

END OF TASK**INSTALLATION**

Install Tank or Berm Liner Drain Valve.

END OF TASK**END OF WORK PACKAGE**

**FIELD MAINTENANCE
TANK DRAIN HOSE ASSEMBLY, BOWL x CAM
SERVICE AND REPAIR**

INITIAL SETUP:**Tools and Special Tools**

Adapter, socket wrench, 3/8 in. female square end 1/2 in. male square end (WP 0073, Item 3)
 Tool kit, general mechanic's (WP 0073, Item 1)
 Wrench, torque, 0-175 ft•lb (WP 0073, Item 2)

Personnel Required

Quartermaster and Chemical Equipment
 Repairer 63J

Materials/Parts

Detergent, general purpose (WP 0075, Item 2)
 Dry cleaning solvent (WP 0075, Item 3)
 Gasket-Buna-N (WP 0076, Item 8)
 Gloves, chemical and oil protective (WP 0075,
 Item 4)
 Goggles, industrial (WP 0075, Item 5)
 Rag, wiping (WP 0075, Item 6)

Equipment Condition

Tank Envelope drained (WP 0005)

DISASSEMBLY

1. Remove Tank Drain Hose Assembly, Bowl x Cam (Figure 1, Item 3).
2. Remove eight Screws (Figure 1, Item 1) and Washers (Figure 1, Item 2) from Tank Drain Hose Assembly, Bowl x Cam (Figure 1, Item 3) and Tank Envelope fitting (Figure 1, Item 5).
3. Remove Tank Drain Hose Assembly, Bowl x Cam (Figure 1, Item 3) from Tank Envelope fitting (Figure 1, Item 5) discard if damaged or store for reuse.
4. Remove Gasket (Figure 1, Item 4). Discard Gasket.

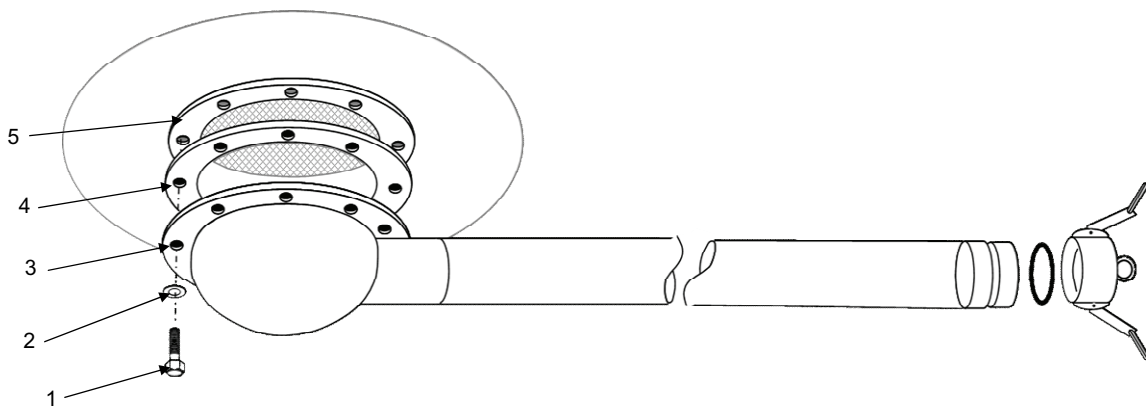

Figure 1. Tank Drain Hose Assembly, Bowl x Cam.

END OF TASK

SERVICE

1. Flush Tank Drain Hose Assembly, Bowl x Cam (Figure 1, Item 3) with soapy water.
2. Rinse out Tank Drain Hose Assembly, Bowl x Cam (Figure 1, Item 3) thoroughly and air dry.

WARNING

Dry cleaning solvent, A-A-59601, used to clean parts, is potentially dangerous to personnel. It produces toxic and flammable fumes. Use only in well ventilated areas. Avoid repeated and prolonged skin contact. Wear protective rubber gloves and chemical splash goggles. Do not use solvent near an open flame or near excessive heat. The flash point of the solvent is 100°F to 130°F (38°C to 54°C). Failure to comply with this warning may result in serious injury or death to personnel.

CAUTION

Dry cleaning solvent, A-A-59601, used to clean parts, must not come into contact with any part of Tank Envelope fabric. Damage to fabric will occur.

3. Clean mating surface of Tank Drain Hose Assembly, Bowl x Cam (Figure 1, Item 3) and Tank Envelope fitting (Figure 1, Item 5) with dry cleaning solvent (WP 0075, Item 3) and dry thoroughly with wiping rags (WP 0075, Item 6).
4. Inspect Tank Drain Hose Assembly, Bowl x Cam (Figure 1, Item 3) for cracks, tears or wear.

END OF TASK**ASSEMBLY**

1. Install Tank Drain Hose Assembly, Bowl x Cam (Figure 1, Item 3).
 - a. Position Gasket (Figure 1, Item 4) and Tank Drain Hose Assembly, Bowl x Cam (Figure 1, Item 3) to Tank Envelope fitting (Figure 1, Item 5).
 - b. Install eight Screws (Figure 1, Item 1) and Washers (Figure 1, Item 2) to Tank Drain Hose Assembly, Bowl x Cam (Figure 1, Item 3) and Tank Envelope fitting (Figure 1, Item 5).
 - c. Torque Screws (Figure 1, Item 1) to 11ft•lb (15 N•m).
 - d. Connect Tank Drain Valve to Tank Envelope, add fuel to Tank Envelope, and check for leaks.

END OF TASK**END OF WORK PACKAGE**

**FIELD MAINTENANCE
TANK DRAIN HOSE ASSEMBLY, CAM x CAM
SERVICE AND REPAIR**

INITIAL SETUP:**Tools and Special Tools**

Tool kit, general mechanic's (WP 0076, Item 1)

Personnel Required

Quartermaster and Chemical Equipment
Repairer 63J

Materials/Parts

Detergent, general purpose (WP 0078, Item 2)

Gasket (2) (WP 0079, Item 5)

NOTE

Repair of the Tank Drain Hose Assembly, Cam X Cam is limited to replacement of unserviceable components.

DISASSEMBLY

1. Pull outward on two cam-lever arms (Figure 1, Item 3).
2. Remove Dust Cap (Figure 1, Item 4) from Male Coupling (Figure 1, item 7).
3. Remove Gasket (Figure 1, Item 2) from Dust Cap (Figure 1, Item 4). Discard Gasket.
4. Remove Chain (Figure 1, Item 6) and two Key Holders (Figure 1, Item 5) from Dust Cap (Figure 1, Item 4) and Male Coupling (Figure 1, item 7).
5. Pull outward on two cam-lever arms (Figure 1, Item 8).
6. Remove Dust Plug (Figure 1, Item 12) from Female Coupling (Figure 1, Item 9).
7. Remove Chain (Figure 1, Item 10) and two Key Holders (Figure 1, Item 11) from Dust Plug (Figure 1, Item 12) and Female Coupling (Figure 1, Item 9).
8. Remove Gasket (Figure 1, Item 13) in Female Coupling (Figure 1, Item 9). Discard Gasket.

END OF TASK

SERVICE

1. Flush out the Berm Liner Drain Hose Assembly, Cam X Cam (Figure 1, Item 1) with, soapy water.
2. Rinse out the Berm Liner Drain Hose Assembly, Cam X Cam (Figure 1, Item 1) thoroughly and air-dry.
3. Inspect the Berm Liner Drain Hose Assembly, Cam X Cam (Figure 1, Item 1) for cracks, tears, or wear, and ensure that the hose bands are securely fastened to the couplings.
4. Inspect all mechanical parts for cracks, dents, breaks and wear. Replace any unserviceable components.

END OF TASK

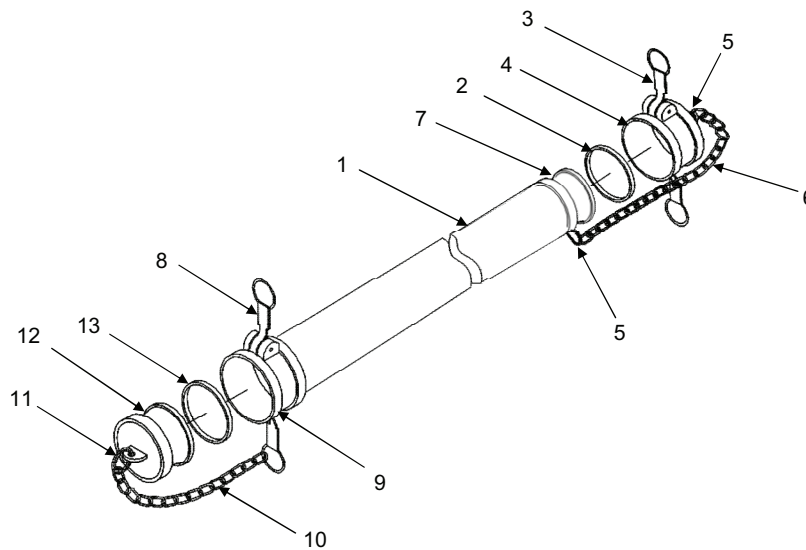

Figure 1. Tank Drain Hose Assembly, Cam X Cam.

ASSEMBLY

1. Install Chain (Figure 1, Item 10) and two Key Holders (Figure 1, Item 11) on Dust Plug (Figure 1, Item 12) and Female Coupling (Figure 1, Item 9).
2. Install new Gasket (Figure 1, Item 13) in Female Coupling (Figure 1, Item 9).
3. Push cam-lever arms (Figure 1, Item 8) on Female Coupling (Figure 1, Item 9) outward, away from body of Female Coupling (Figure 1, Item 9).
4. Install Dust Plug (Figure 1, Item 12) in Female Coupling (Figure 1, Item 9).
5. Push cam-lever arms (Figure 1, Item 8) on Female Coupling (Figure 1, Item 9) inward, toward body of Female Coupling (Figure 1, Item 9) until locked.
6. Install Chain (Figure 1, Item 6) and two Key Holders (Figure 1, Item 5) on Dust Cap (Figure 1, Item 4) and Male Coupling (Figure 1, Item 7).
7. Install new Gasket (Figure 1, Item 2) in Dust Cap (Figure 1, Item 4).
8. Push cam-lever arms (Figure 1, Item 3) on Dust Cap (Figure 1, Item 4) outward, away from body of Dust Cap (Figure 1, Item 4).

INSTALLATION – CONTINUED

9. Install Dust Cap (Figure 1, Item 3) on Male Coupling (Figure 1, Item 7).
10. Push cam-lever arms (Figure 1, Item 3) on Dust Cap (Figure 1, Item 4) inward, toward body of Dust Cap (Figure 1, Item 4) until locked.

END OF TASK**END OF WORK PACKAGE**

**FIELD MAINTENANCE
VENT PORT ASSEMBLY
SERVICE AND REPAIR**

INITIAL SETUP:**Tools and Special Tools**

Tool kit, general mechanic's (WP 0073, Item 1)
Wrench, torque, 0-175 ft•lb (WP 0073, Item 2)

Personnel Required

Quartermaster and Chemical Equipment
Repairer 63J

Materials/Parts

Dry cleaning solvent (WP 0075, Item 3)
Gasket (2) (WP 0076, Item 3)
Gloves, chemical and oil protective (WP 0075,
Item 4)
Goggles, industrial (WP 0075, Item 5)
O-Ring (WP 0076, Item 4)
Rag, wiping (WP 0075, Item 6)
Silicone compound (WP 0075, Item 8)

Equipment Condition

Tank Envelope drained (WP 0005)

REMOVAL

1. Remove eight Screws (Figure 1, Item 8) and Washers (Figure 1, Item 9) from Flanged Adapter (Figure 1, Item 11).
2. Lift Flanged Adapter (Figure 1, Item 11) from Tank Envelope fitting (Figure 1, Item 13).
3. Remove and discard O-ring (Figure 1, Item 12) from packing groove (Figure 1, Item 14) located in Tank Envelope fitting (Figure 1, Item 13).

END OF TASK**DISASSEMBLY**

1. Remove Coupling Half (Figure 1, Item 4) from Flanged Adapter (Figure 1, Item 11) by pulling outward on cam-lever arms (Figure 1, Item 18), and lifting Coupling Half (Figure 1, Item 4) from Flanged Adapter (Figure 1, Item 11).
2. Remove and discard Gasket (Figure 1, Item 17) from Coupling Half (Figure 1, Item 4).
3. Rotate Vent Pipe (Figure 1, Item 3) counterclockwise until Vent Pipe threads disengage from Coupling Half (Figure 1, Item 4), and remove Coupling Half (Figure 1, Item 4) from Vent Pipe (Figure 1, Item 3).
4. Rotate Vent Cap (Figure 1, Item 1) counterclockwise until Vent Cap threads disengage from Vent Pipe (Figure 1, Item 3). Remove Vent Cap (Figure 1, Item 1) from Vent Pipe (Figure 1, Item 3).
5. Rotate Flame Arrestor (Figure 1, Item 2) counterclockwise until Flame Arrestor threads disengage from Vent Cap (Figure 1, Item 1). Remove Flame Arrestor (Figure 1, Item 2) from Vent Cap (Figure 1, Item 1).
6. Disconnect Key Holder (Figure 1, Item 10) from Flanged Adapter (Figure 1, Item 11).
7. Remove and discard Gasket (Figure 1, Item 7) from inside Dust Cap (Figure 1, Item 6).

END OF TASK

SERVICE

WARNING

Dry cleaning solvent, A-A-59601, used to clean parts, is potentially dangerous to personnel. It produces toxic and flammable fumes. Use only in well ventilated areas. Avoid repeated and prolonged skin contact. Wear protective rubber gloves and chemical splash goggles. Do not use solvent near an open flame or near excessive heat. The flash point of the solvent is 100°F to 130°F (38°C to 54°C). Failure to comply with this warning may result in serious injury or death to personnel.

CAUTION

Dry cleaning solvent, A-A-59601, used to clean parts, must not come into contact with any part of Tank Envelope fabric. Damage to fabric will occur.

1. Clean all parts with dry cleaning solvent (WP 0075, Item 3), and dry thoroughly with wiping rags (WP 0075, Item 6).
2. Clean preformed packing grooves with dry cleaning solvent (WP 0075, Item 3), and dry thoroughly with wiping rags (WP 0075, Item 6).
3. Inspect all mechanical parts for cracks, dents, breaks, and wear. Replace component if unserviceable.
4. Check that vent hole in Flame Arrestor is clear of all debris.

END OF TASK

Figure 1. Vent Port Assembly.

ASSEMBLY

1. Install Flame Arrestor (Figure 1, Item 2) into Vent Cap (Figure 1, Item 1). Rotate Flame Arrestor (Figure 1, Item 2) clockwise until threads are firmly seated in Vent Cap (Figure 1, Item 1).
2. Install Flame Arrestor (Figure 1, Item 2) into Vent Pipe (Figure 1, Item 3) until Vent Pipe (Figure 1, Item 3) contacts Vent Cap (Figure 1, Item 1).
3. Rotate Vent Cap (Figure 1, Item 1) clockwise until Vent Pipe (Figure 1, Item 3) and Vent Cap (Figure 1, Item 1) are firmly seated together.
4. Install Vent Pipe (Figure 1, Item 3) into Coupling Half (Figure 1, Item 4). Rotate Vent Pipe (Figure 1, Item 3) clockwise until it firmly seats in Coupling Half (Figure 1, Item 4).
5. Install new Gasket (Figure 1, Item 17) into Coupling Half (Figure 1, Item 4).
6. Install Coupling Half (Figure 1, Item 4) on Flanged Adapter (Figure 1, Item 11) pushing in cam-lever arms (Figure 1, Item 18) until locked in place.
7. Install new Gasket (Figure 1, Item 7) inside Dust Cap (Figure 1, Item 6).
8. Connect Key Holder (Figure 1, Item 10) to Flanged Adapter (Figure 1, Item 11).

END OF TASK**INSTALLATION**

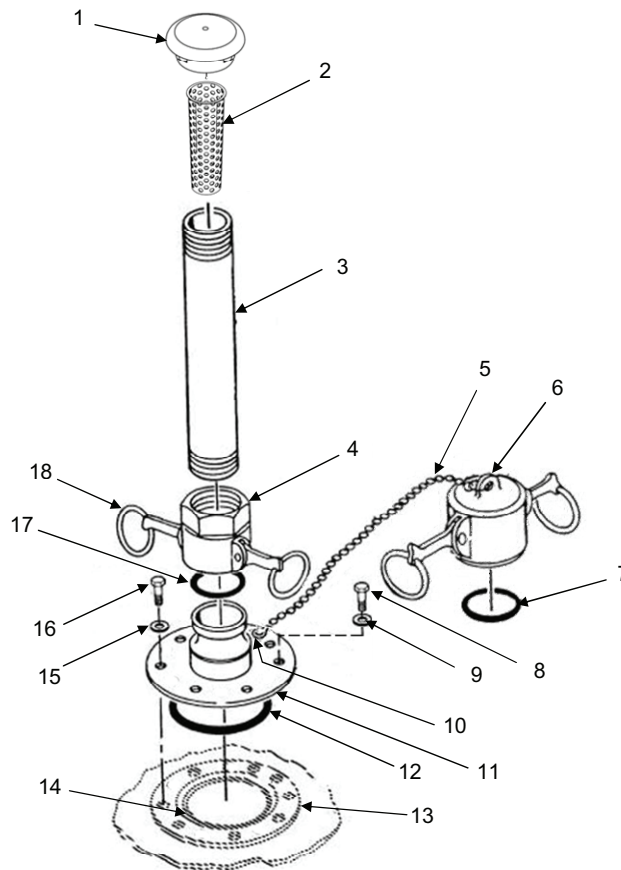
1. Lubricate new O-ring (Figure 1, Item 12) with silicone compound (WP 0075, Item 8).
2. Install O-ring (Figure 1, Item 12) into packing groove (Figure 1, Item 14) located in tank fitting (Figure 1, Item 13).
3. Position Flanged Adapter (Figure 1, Item 11) over Tank Envelope fitting (Figure 1, Item 13).
4. Install eight Washers (Figure 1, Item 9) and Screws (Figure 1, Item 8) through Flanged Adapter (Figure 1, Item 11) and Tank Envelope fitting (Figure 1, Item 13) holes.
5. Torque Screws (Figure 1, Item 8) to 11 ft•lb (15 N•m).

END OF TASK**END OF WORK PACKAGE**

**FIELD MAINTENANCE
FILLER/DISCHARGE ASSEMBLY
SERVICE AND REPAIR**

INITIAL SETUP:**Tools and Special Tools**

Tool kit, general mechanic's (WP 0073, Item 1)
Wrench, torque, 0-175 ft•lb (WP 0073, Item 2)

Personnel Required

Quartermaster and Chemical Equipment
Repairer 63J

Materials/Parts

Detergent, general purpose (WP 0075, Item 2)
Dry cleaning solvent (WP 0075, Item 3)
Gasket (8) (WP 0076, Item 1)
Gasket (3) (WP 0076, Item 2)
Gasket (WP 0076, Item 6)
Gloves, chemical and oil protective (WP 0075,
Item 4)
Goggles, industrial (WP 0075, Item 5)
O-Ring (WP 0076, Item 6)
Rag, wiping (WP 0075, Item 6)
Silicone compound (WP 0075, Item 8)
Washer, lock (8) (WP 0076, Item 7)

Equipment Condition

Tank Envelope drained (WP 0005)

DISASSEMBLY**CAUTION**

Be sure to take off Compression Plate before removing Flanged Adapter. Flanged Adapter is bolted to Compression Plate and Suction Stub. If Flanged Adapter is removed first, the hex head nuts bolted to the Suction Stub will fall into Tank Envelope.

NOTE

Discharge fitting requires a Discharge Elbow (female x male). Filler fitting requires a Filler Elbow (female x female).

1. Remove Filler/Discharge Elbow (Figure 1, Item 1) by pulling outward on cam-lever arms (Figure 1, Item 2), and lifting Filler/Discharge Elbow (Figure 1, Item 1) from Flanged Adapter (Figure 1, Item 4).
2. Remove Filler/Discharge Elbow Gasket(s) (Figure 1, Item 3).
 - a. Remove and discard Gasket (Figure 1, Item 3) from inside Discharge Elbow (Figure 1, Item 1).
 - b. Remove and discard Gaskets (Figure 1, Item 3) from inside Filler Elbow (Figure 1, Item 1).
3. Remove twenty Screws (Figure 1, Item 14) and Washers (Figure 1, Item 13) from Compression Plate (Figure 1, Item 5).
4. Lift Compression Plate (Figure 1, Item 5) from Tank Envelope fitting (Figure 1, Item 8).
5. Remove and discard O-ring (Figure 1, Item 7) from packing groove located in Tank Envelope fitting (Figure 1, Item 8).
6. Remove eight Nuts (Figure 1, Item 10), Lock Washers (Figure 1, Items 11 and 12), Screws (Figure 1, Item 16), and Gaskets (Figure 1, Item 20) from Suction Stub (Figure 1, Item 9) Flanged Adapter (Figure 1, Item 4), and Gasket (Figure 1, Item 6).
7. Discard Lock Washers (Figure 1, Item 11 and 12) and Gaskets (Figure 1, Items 6 and 20).

DISASSEMBLY – CONTINUED

8. Remove and discard Gasket (Figure 1, Item 3) from inside Dust Cap (Figure 1, Item 15).

END OF TASK

Figure 1. Filler/Discharge Assembly.

SERVICE**WARNING**

Dry cleaning solvent, A-A-59601, used to clean parts, is potentially dangerous to personnel. It produces toxic and flammable fumes. Use only in well ventilated areas. Avoid repeated and prolonged skin contact. Wear protective rubber gloves and chemical splash goggles. Do not use solvent near an open flame or near excessive heat. The flash point of the solvent is 100°F to 130°F (38°C to 54°C). Failure to comply with this warning may result in serious injury or death to personnel.

CAUTION

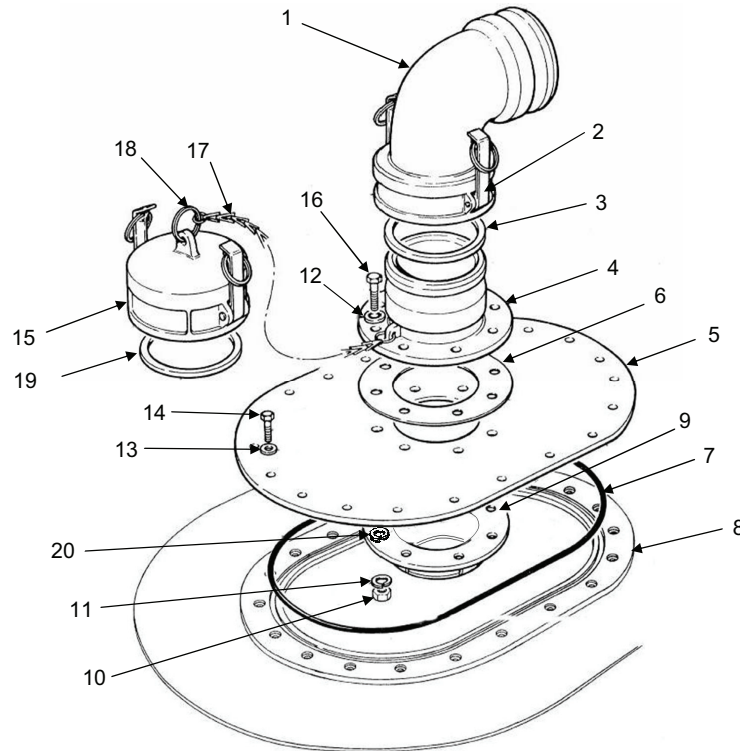
Dry cleaning solvent, A-A-59601, used to clean parts, must not come into contact with any part of Tank Envelope fabric. Damage to fabric will occur.

1. Clean all parts with dry cleaning solvent (WP 0075, Item 3) and dry thoroughly with wiping rags (WP 0075, Item 6).
2. Clean packing grooves thoroughly with general purpose detergent (WP 0075, Item 2) and water.

SERVICE – CONTINUED

3. Clean all Gasket-sealing surfaces thoroughly with general purpose detergent (WP 0075, Item 2) and water.
4. Inspect all mechanical parts for cracks, dents, breaks, and wear. Replace component if unserviceable.

END OF TASK**ASSEMBLY**

1. Install new Gasket (Figure 1, Item 3) into Dust Cap (Figure 1, Item 15).
2. Install Filler/Discharge Elbow Gasket(s) (Figure 1, Item 3).
 - a. Install new Gasket (Figure 1, Item 3) from inside Discharge Elbow (Figure 1, Item 1).
 - b. Install new Gaskets (Figure 1, Item 3) from inside Filler Elbow (Figure 1, Item 1).
3. Place Suction Stub (Figure 1, Item 9) on a hard, flat surface with eight bolt holes positioned up.
4. Position new Gaskets (Figure 1, Item 12) over each bolt hole in Suction Stub (Figure 1, Item 9).
5. Position Compression Plate (Figure 1, Item 5), on top of new Gaskets (Figure 1, Item 12), and align holes.
6. Position new Flanged Adapter Gasket (Figure 1, Item 6) on closure plate (Figure 1, Item 5), and align holes.
7. Position Flanged Adapter (Figure 1, Item 3) on Gasket (Figure 1, Item 6), and align holes.
8. Install Screws (Figure 1, Item 16) and new Gaskets (Figure 1, Item 12) through holes in Flanged Adapter (Figure 1, Item 4), thread Screws (Figure 1, Item 16) through until ends protrude through Suction Stub (Figure 1, Item 9).
9. Assemble new Gaskets (Figure 1, Item 12), new lock Washers (Figure 1, Item 11), and nuts (Figure 1, Item 10) to Screws (Figure 1, Item 16). Torque fastening hardware to 18 ft•lb (24.40 N•m).
10. Position closure plate (Figure 1, Item 5) on Tank Envelope fitting (Figure 1, Item 8).

NOTE

Lift Tank Envelope to Compression Plate to begin threading Screws through Tank Envelope fitting.

11. Install Screws (Figure 1, Item 14) through Compression Plate (Figure 1, Item 7) and into Tank Envelope fitting (Figure 1, Item 8).
12. Torque fastening Screws (Figure 1, Item 14) to 11 ft•lb (15 N•m).
13. Position Filler/Discharge Elbow (Figure 1, Item 1) on Flanged Adapter (Figure 1, Item 4), and push cam-lever arms (Figure 1, Item 2) inward, locking Filler/Discharge Elbow (Figure 1, Item 1) to Flanged Adapter (Figure 1, Item 4).

END OF TASK**END OF WORK PACKAGE**

**FIELD MAINTENANCE
TANK DRAIN FITTING ASSEMBLY
SERVICE AND REPAIR**

INITIAL SETUP:**Tools and Special Tools**

Tool kit, general mechanic's (WP 0073, Item 1)
Wrench, torque, 0-175 ft•lb (WP 0073, Item 2)

Personnel Required

Quartermaster and Chemical Equipment
Repairer 63J

Materials/Parts

Detergent, general purpose (WP 0075, Item 2)
Dry cleaning solvent (WP 0075, Item 3)
Gasket-Buna-N (WP 0076, Item 8)
Gloves, chemical and oil protective (WP 0075,
Item 4)
Goggles, industrial (WP 0075, Item 5)
Rag, wiping (WP 0075, Item 6)

Equipment Condition

Tank Envelope drained (WP 0005)

DISASSEMBLY

1. Remove eight Screws (Figure 1, Item 1) and Washers (Figure 1, Item 2) from Blind Flange Cover (Figure 1, Item 3) and Tank Envelope drain (Figure 1, Item 5).
2. Remove Blind Flange Cover (Figure 1, Item 3) from Tank Envelope drain (Figure 1, Item 5). Discard if damaged or store for reuse.
3. Remove and discard Gasket (Figure 1, Item 4).

END OF TASK

Figure 1. Tank Drain.

SERVICE**WARNING**

Dry cleaning solvent, A-A-59601, used to clean parts, is potentially dangerous to personnel. It produces toxic and flammable fumes. Use only in well ventilated areas. Avoid repeated and prolonged skin contact. Wear protective rubber gloves and chemical splash goggles. Do not use solvent near an open flame or near excessive heat. The flash point of the solvent is 100°F to 130°F (38°C to 54°C). Failure to comply with this warning may result in serious injury or death to personnel.

CAUTION

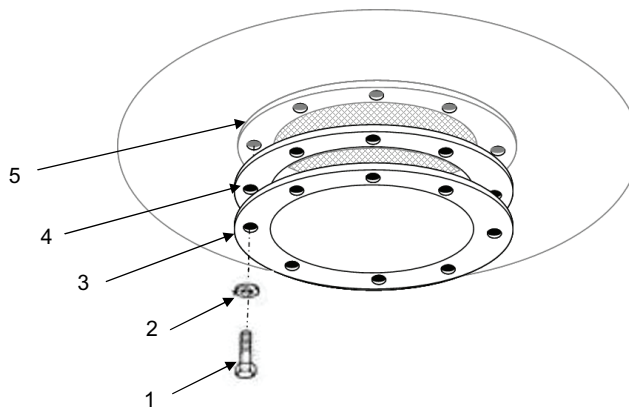
Dry cleaning solvent, A-A-59601, used to clean parts, must not come into contact with any part of Tank Envelope fabric. Damage to fabric will occur.

1. Clean mating surface of Tank Envelope drain (Figure 1, Item 5) with dry cleaning solvent (WP 0075, Item 3) and dry thoroughly with wiping rags (WP 0075, Item 6).
2. Inspect all mechanical parts for cracks, dents, breaks, and wear. Replace component if unserviceable.

END OF TASK**ASSEMBLY**

1. Position Gasket (Figure 1, Item 4) and Blind Flange Cover (Figure 1, Item 3) to Tank Envelope drain (Figure 1, Item 5).
2. Install eight Screws (Figure 1, Item 1) and Washers (Figure 1, Item 2) to Blind Flange Cover (Figure 1, Item 3) and Tank Envelope drain (Figure 1, Item 5).
3. Torque Screws (Figure 1, Item 1) to 11ft•lb (15 N•m).
4. Add fuel to Tank Envelope and check for leaks.

END OF TASK**END OF WORK PACKAGE**

**FIELD MAINTENANCE
TANK ENVELOPE
SERVICE**

INITIAL SETUP:**Tools and Special Tools**

Tool kit, general mechanic's (WP 0073, Item 1)

Personnel Required

Quartermaster and Chemical Equipment
Repairer 63J

Materials/Parts

Detergent, general purpose (WP 0075, Item 2)
Dry cleaning solvent (WP 0075, Item 3)
Gloves, chemical and oil protective (WP 0075,
Item 4)
Goggles, industrial (WP 0075, Item 5)
Rag, wiping (WP 0075, Item 6)

References

WP 0042
WP 0043
WP 0044
WP 0045

Equipment Condition

Tank Envelope drained (WP 0005)

REMOVAL

1. Remove Vent Port Assembly (Figure 1, Item 1) (WP 0044).
2. Remove Tank Drain Hose Assembly, Cam x Cam (WP 0043).
3. Remove Tank Drain Hose Assembly, Bowl x Cam (Figure 1, Item 3) (WP 0042).
4. Remove Filler/Discharge Assemblies (Figure 1, Item 3) (WP 0045).

END OF TASK

Figure 1. Tank Assembly.

SERVICE**WARNING**

Dry cleaning solvent, A-A-59601, used to clean parts, is potentially dangerous to personnel. It produces toxic and flammable fumes. Use only in well ventilated areas. Avoid repeated and prolonged skin contact. Wear protective rubber gloves and chemical splash goggles. Do not use solvent near an open flame or near excessive heat. The flash point of the solvent is 100°F to 130°F (38°C to 54°C). Failure to comply with this warning may result in serious injury or death to personnel.

CAUTION

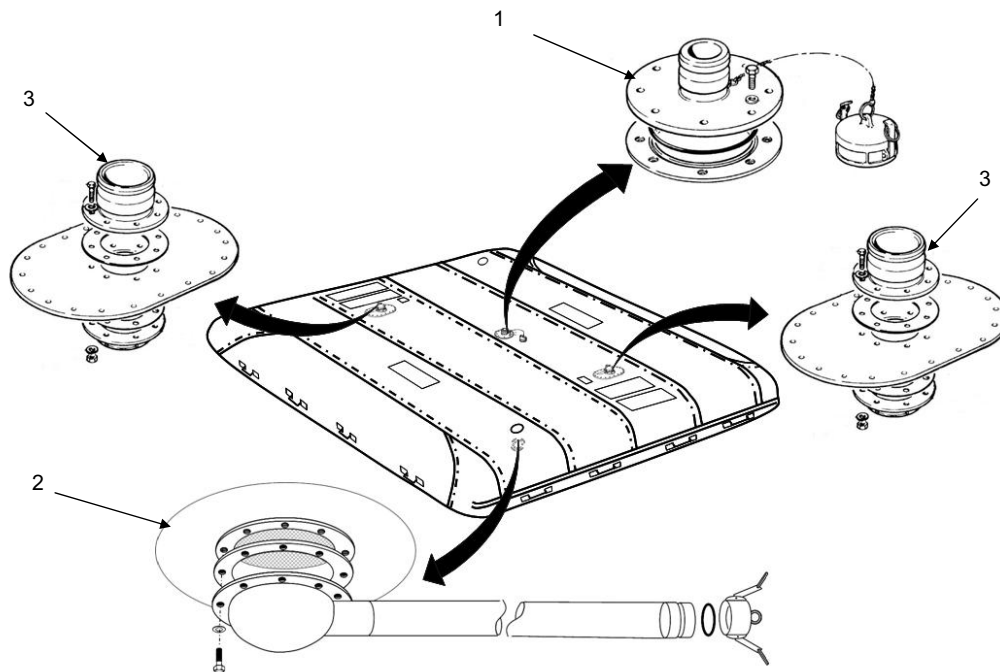
Dry cleaning solvent, A-A-59601, used to clean parts, must not come into contact with any part of Tank Envelope fabric. Damage to fabric will occur.

1. Clean all mechanical parts with dry cleaning solvent (WP 0075, Item 3) and dry thoroughly with wiping rags (WP 0075, Item 6).
2. Clean Tank Envelope exterior with general purpose detergent (WP 0075, Item 2) and water.
3. Inspect all mechanical parts for cracks, dents, breaks, and wear. Replace component if unserviceable.

END OF TASK**INSTALLATION****NOTE**

Prior to installation of Tank Assembly components, unroll drain end first.

1. Unroll Tank Envelope and unfold sides using tank handles to position tank.
2. Install Filler/Discharge Assemblies (WP 00445).
3. Install Tank Drain Hose Assembly, Bowl x Cam (WP 0042).
4. Install Tank Drain Hose Assembly, Cam x Cam (WP 0043).
5. Install Vent Port Assembly (WP 0044).

END OF TASK**END OF WORK PACKAGE**

**FIELD MAINTENANCE
BERM LINER DRAIN FITTING ASSEMBLY
SERVICE AND REPAIR**

INITIAL SETUP:**Tools and Special Tools**

Tool kit, general mechanic's (WP 0073, Item 1)
Wrench, torque, 0-175 ft•lb (WP 0073, Item 2)

Personnel Required

Quartermaster and Chemical Equipment
Repairer 63J

Materials/Parts

Detergent, general purpose (WP 0075, Item 2)
Dry cleaning solvent (WP 0075, Item 3)
Gasket-Buna-N (WP 0076, Item 8)
Gloves, chemical and oil protective (WP 0075,
Item 4)
Goggles, industrial (WP 0075, Item 5)
Rag, wiping (WP 0075, Item 6)

Equipment Condition

Tank Envelope drained (WP 0005)

DISASSEMBLY

1. Remove eight Screws (Figure 1, Item 1) and Washers (Figure 1, Item 2) from Blind Flange Cover (Figure 1, Item 3) and Berm Liner drain (Figure 1, Item 5).
2. Remove Blind Flange Cover (Figure 1, Item 3) from Berm Liner drain (Figure 1, Item 5). Discard if damaged or store for reuse.
3. Remove and discard Gasket (Figure 1, Item 4).

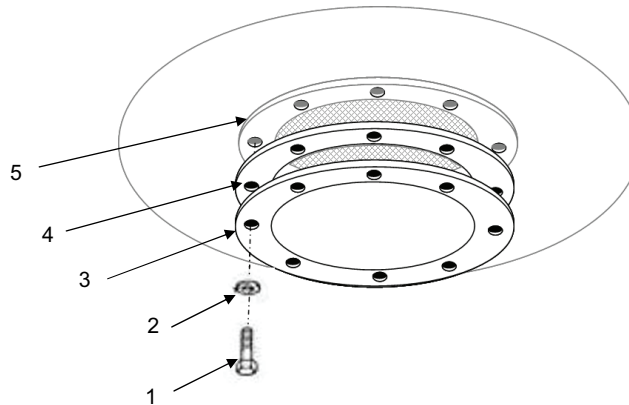

Figure 1. Berm Liner Drain Fitting Assembly.

SERVICE**WARNING**

Dry cleaning solvent, A-A-59601, used to clean parts, is potentially dangerous to personnel. It produces toxic and flammable fumes. Use only in well ventilated areas. Avoid repeated and prolonged skin contact. Wear protective rubber gloves and chemical splash goggles. Do not use solvent near an open flame or near excessive heat. The flash point of the solvent is 100°F to 130°F (38°C to 54°C). Failure to comply with this warning may result in serious injury or death to personnel.

CAUTION

Dry cleaning solvent, A-A-59601, used to clean parts, must not come into contact with any part of Berm Liner fabric. Damage to fabric will occur.

3. Clean mating surface of Berm Liner drain (Figure 1, Item 5) with dry cleaning solvent (WP 0075, Item 3) and dry thoroughly with wiping rags (WP 0075, Item 6).
4. Inspect all mechanical parts for cracks, dents, breaks, and wear. Replace component if unserviceable.
5. Dispose of wiping rags (WP 0075, Item 6) per local procedures.

END OF TASK**ASSEMBLY**

1. Position new Gasket (Figure 1, Item 4) and Blind Flange Cover (Figure 1, Item 3) to Berm Liner drain (Figure 1, Item 5).
2. Install eight Screws (Figure 1, Item 1) and Washers (Figure 1, Item 2) to Blind Flange Cover (Figure 1, Item 3) and Berm Liner drain (Figure 1, Item 5).
3. Torque Screws (Figure 1, Item 1) to 11ft•lb (15 N•m).
4. Add fuel to Berm Liner and check for leaks.

END OF TASK**END OF WORK PACKAGE**

FIELD MAINTENANCE
BERM LINER DRAIN HOSE ASSEMBLY, BOWL x CAM
SERVICE AND REPAIR

INITIAL SETUP:**Tools and Special Tools**

Adapter, socket wrench, 3/8 in. female square end 1/2 in. male square end (WP 0073, Item 3)
 Tool kit, general mechanic's (WP 0073, Item 1)
 Wrench, torque, 0-175 ft•lb (WP 0073, Item 2)

Personnel Required

Quartermaster and Chemical Equipment Repairer 63J

Materials/Parts

Detergent, general purpose (WP 0075, Item 2)
 Dry cleaning solvent (WP 0075, Item 3)
 Gloves, chemical and oil protective (WP 0075, Item 4)
 Goggles, industrial (WP 0075, Item 5)
 Rag, wiping (WP 0075, Item 6)

Equipment Condition

Tank Envelope drained (WP 0005)

DISASSEMBLE

1. Remove eight Screws (Figure 1, Item 1) and Washers (Figure 1, Item 2) from BERM Liner Drain Hose Assembly, Bowl x Cam (Figure 1, Item 3) and Tank Envelope drain (Figure 1, Item 5).
2. Remove BERM Liner Drain Hose Assembly, Bowl x Cam (Figure 1, Item 3) from Tank Envelope drain (Figure 1, Item 5) discard if damaged or store for reuse.
3. Remove Gasket (Figure 1, Item 4). Discard Gasket.

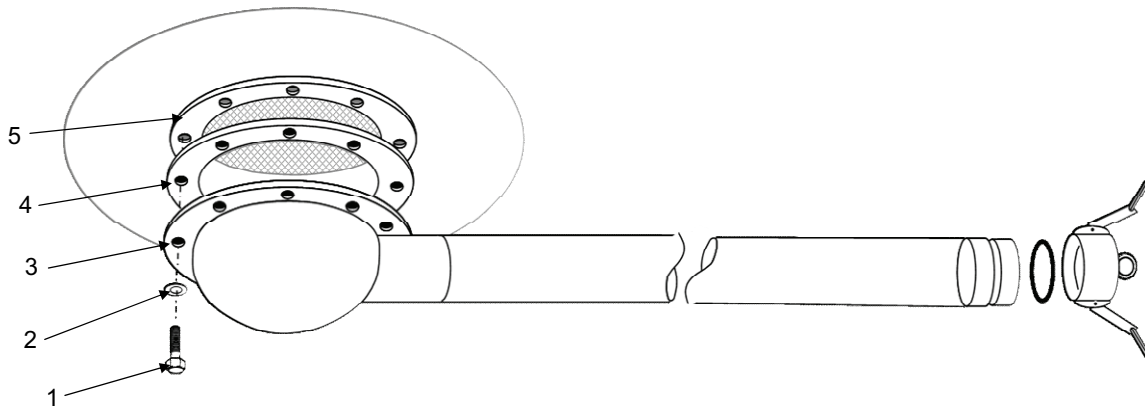

Figure 1. BERM Liner Drain Hose Assembly, Bowl x Cam.

SERVICE

1. Flush Berm Liner Drain Hose Assembly, Bowl x Cam (Figure 1, Item 3) with soapy water.
2. Rinse out Berm Liner Drain Hose Assembly, Bowl x Cam (Figure 1, Item 3) thoroughly and air dry.

WARNING

Dry cleaning solvent, A-A-59601, used to clean parts, is potentially dangerous to personnel. It produces toxic and flammable fumes. Use only in well ventilated areas. Avoid repeated and prolonged skin contact. Wear protective rubber gloves and chemical splash goggles. Do not use solvent near an open flame or near excessive heat. The flash point of the solvent is 100°F to 130°F (38°C to 54°C). Failure to comply with this warning may result in serious injury or death to personnel.

CAUTION

Dry cleaning solvent, A-A-59601, used to clean parts, must not come into contact with any part of Tank Envelope fabric. Damage to fabric will occur.

3. Clean mating surface of Berm Liner Drain Hose Assembly, Bowl x Cam (Figure 1, Item 3) of Tank Envelope drain (Figure 1, Item 5) with dry cleaning solvent (WP 0075, Item 3) and dry thoroughly with wiping rags (WP 0075, Item 6).
4. Inspect Berm Liner Drain Hose Assembly, Bowl x Cam (Figure 1, Item 3) for cracks, tears or wear.

END OF TASK**ASSEMBLE**

1. Install Berm Liner Drain Hose Assembly, Bowl x Cam (Figure 1, Item 3).
2. Position Gaskets (Figure 1, Items 4) and Berm Liner Drain Hose Assembly, Bowl x Cam (Figure 1, Item 3) to Tank Envelope drain (Figure 1, Item 5).
3. Install eight Screws (Figure 1, Item 1) and Washers (Figure 1, Item 2) to Berm Liner Drain Hose Assembly, Bowl x Cam (Figure 1, Item 3) and Tank Envelope drain (Figure 1, Item 5).
4. Torque Screws (Figure 1, Item 1) to 11ft•lb (15 N•m).
5. Connect Berm Liner Drain Hose Assembly and Berm Liner Drain Valve to Tank Envelope, add fuel to Tank Envelope, and check for leaks.

END OF TASK**END OF WORK PACKAGE**

**FIELD MAINTENANCE
BERM LINER DRAIN HOSE ASSEMBLY, CAM x CAM
SERVICE AND REPAIR**

INITIAL SETUP:**Tools and Special Tools**

Tool kit, general mechanic's (WP 0076, Item 1)

Personnel Required

Quartermaster and Chemical Equipment
Repairer 63J

Materials/Parts

Detergent, general purpose (WP 0078, Item 2)
Gasket (2) (WP 0079, Item 6)

NOTE

Repair of the Berm Liner Drain Hose Assembly, Cam x Cam is limited to replacement of unserviceable components.

DISASSEMBLY

1. Pull outward on two cam-lever arms (Figure 1, Item 3).
2. Remove Dust Cap (Figure 1, Item 4) from Male Coupling (Figure 1, item 7).
3. Remove Gasket (Figure 1, Item 2) from Dust Cap (Figure 1, Item 4). Discard Gasket.
4. Remove Chain (Figure 1, Item 6) and two Key Holders (Figure 1, Item 5) from Dust Cap (Figure 1, Item 4) and Male Coupling (Figure 1, item 7).
5. Pull outward on two cam-lever arms (Figure 1, Item 8).
6. Remove Dust Plug (Figure 1, Item 12) from Female Coupling (Figure 1, Item 9).
7. Remove Chain (Figure 1, Item 10) and two Key Holders (Figure 1, Item 11) from Dust Plug (Figure 1, Item 12) and Female Coupling (Figure 1, Item 9).
8. Remove Gasket (Figure 1, Item 13) in Female Coupling (Figure 1, Item 9). Discard Gasket.

END OF TASK

SERVICE

1. Flush out the Berm Liner Drain Hose Assembly, Cam x Cam (Figure 1, Item 1) with, soapy water.
2. Rinse out the Berm Liner Drain Hose Assembly, Cam x Cam (Figure 1, Item 1) thoroughly and air-dry.
3. Inspect the Berm Liner Drain Hose Assembly, Cam x Cam (Figure 1, Item 1) for cracks, tears, or wear, and ensure that the hose bands are securely fastened to the couplings.
4. Inspect all mechanical parts for cracks, dents, breaks and wear. Replace any unserviceable components.

END OF TASK

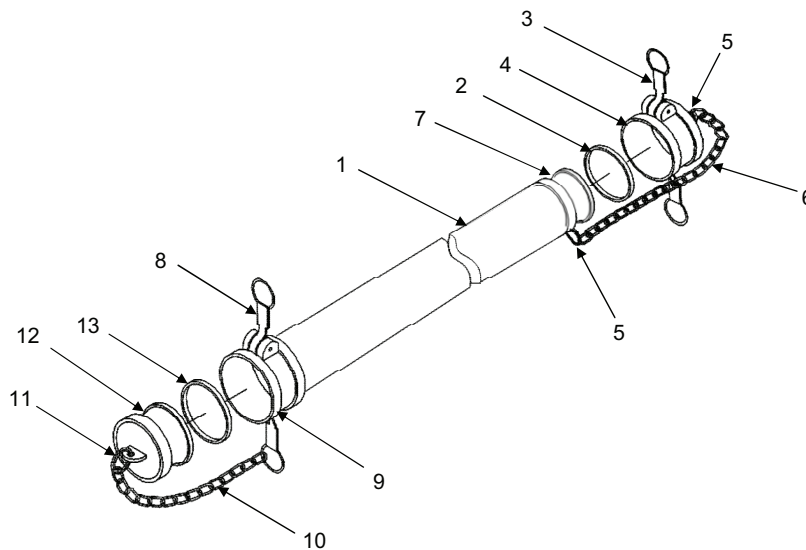

Figure 1. Berm Liner Drain Hose Assembly, Cam x Cam.

ASSEMBLY

1. Install Chain (Figure 1, Item 10) and two Key Holders (Figure 1, Item 11) on Dust Plug (Figure 1, Item 12) and Female Coupling (Figure 1, Item 9).
2. Install new Gasket (Figure 1, Item 13) in Female Coupling (Figure 1, Item 9).
3. Push cam-lever arms (Figure 1, Item 8) on Female Coupling (Figure 1, Item 9) outward, away from body of Female Coupling (Figure 1, Item 9).
4. Install Dust Plug (Figure 1, Item 12) in Female Coupling (Figure 1, Item 9).
5. Push cam-lever arms (Figure 1, Item 8) on Female Coupling (Figure 1, Item 9) inward, toward body of Female Coupling (Figure 1, Item 9) until locked.
6. Install Chain (Figure 1, Item 6) and two Key Holders (Figure 1, Item 5) on Dust Cap (Figure 1, Item 4) and Male Coupling (Figure 1, Item 7).
7. Install new Gasket (Figure 1, Item 2) in Dust Cap (Figure 1, Item 4).
8. Push cam-lever arms (Figure 1, Item 3) on Dust Cap (Figure 1, Item 4) outward, away from body of Dust Cap (Figure 1, Item 4).

ASSEMBLY – CONTINUED

9. Install Dust Cap (Figure 1, Item 3) on Male Coupling (Figure 1, Item 7).
10. Push cam-lever arms (Figure 1, Item 3) on Dust Cap (Figure 1, Item 4) inward, toward body of Dust Cap (Figure 1, Item 4) until locked.

END OF TASK**END OF WORK PACKAGE**

**FIELD MAINTENANCE
TANK, FABRIC, COLLAPSIBLE, FUEL STORAGE, 20,000 GALLON
PREPARATION FOR STORAGE AND SHIPMENT**

PREPARATION FOR STORAGE AND SHIPMENT

WARNING

Sludge that accumulates at bottom of Tank Envelope gives off toxic and explosive vapors. Inhaling these vapors can cause lead poisoning. When cleaning Tank Envelope, provide ample ventilation to dissipate harmful fumes.

Always wear protective goggles, a breathing apparatus, and other protective gear when cleaning Tank Envelope interior. Fuel vapors are toxic and can damage eyes, skin, and lungs.

Fuel vapors are extremely flammable. Exercise care to prevent sparks when working near Tank Envelope. Death or severe personal injury can result if safety precautions are not strictly observed.

CAUTION

Always handle Tank Envelope carefully. Pad components stored with Tank Assembly to avoid chafing during storage or transportation. Rough handling or careless storage can damage tank.

NOTE

Prior to storage, Tank Envelope should be disassembled, purged of all residual fuel and fumes, cleaned, and preserved with all its components for future use.

1. Drain fuel from Tank Envelope (WP 0005).
2. Remove Filler/Discharge Elbows from Filler/Discharge Assemblies (WP 0045).
3. Remove Vent Port Assembly from Flanged Adapter, and install Dust Cap (WP 0044).
4. Remove Filler/Discharge Assembly from Tank Envelope (WP 0045).
5. Flush Tank Envelope with general purpose detergent (WP 0078, Item 2) solution.
 - a. Fill Tank Envelope with roughly 150 to 200 gallons of general purpose detergent (WP 0078, Item 2) solution. Follow the instructions on the general purpose detergent to determine the quantity required to prepare 150 to 200 gallons of solution.
 - b. Circulate solution around the tank by lifting the side of the tank and folding one side of the tank over the other. Repeat for each side of the tank and each end.

PREPARATION FOR STORAGE OR SHIPMENT – CONTINUED**NOTE**

Contact unit/local safety office for disposal of cleaning residue.

6. Drain general purpose detergent (WP 0078, Item 2) solution from Tank Envelope.
7. Squeeze excess detergent solution from Tank Envelope by rolling ends of Tank Envelope towards Tank Drain Fitting.
8. Flush Tank Envelope with clean water.
9. Dry out Tank Envelope by purging it with air pressure. Use a maximum line pressure of 50 lb/sq in. (3.40 atm).
 - a. Insert air hose through Flanged Adapter, placing wiping rags around the air hose at fitting to prevent air from escaping.
 - b. Apply compressed air into Tank Envelope until it expands to 3 ft (0.914 m) in height.
 - c. Remove Dust Cap from Flanged Adapter to allow air to vent from Tank Envelope for 30 minutes.
 - d. Deactivate compressed air source and remove air hose and wiping rags (WP 0075, Item 6).
10. Install Filler/Discharge Assemblies on Tank Envelope (WP 0045).
11. Install Dust Caps on Flanged Adapters of Filler/Discharge Assemblies.
12. Brush debris from Tank Envelope.
13. Fold Tank Envelope from sides towards middle.
14. Roll Tank Envelope from end opposite Tank Envelope drain fitting.
15. Plug exposed hose assembly openings with suitable, clean materials.

END OF TASK**CRATING INSTRUCTIONS**

1. Make sure Tank Envelope has been properly folded (WP 0005).

CAUTION

Use care when packing Tank Envelope. Tank Envelope will be easily damaged by tools, packing box nails, or other sharp objects.

2. Pack Tank Envelope in a close-fitting box or container. When Tank Envelope is disassembled and refolded, it is to be replaced in original box or container.
3. Each Tank Envelope is provided with suitable packing around Tank Envelope to prevent Tank Envelope fabric from being damaged by contact with inside of box or container. When Tank Envelope is replaced in original box or container, packing material is replaced around tank in same manner as received.

END OF TASK**END OF WORK PACKAGE**

CHAPTER 7

PARTS INFORMATION
FOR
TANK, FABRIC, COLLAPSIBLE, FUEL STORAGE,
20,000 GALLON

**FIELD MAINTENANCE
TANK, FABRIC, COLLAPSIBLE, FUEL STORAGE, 20,000 GALLON**

INTRODUCTION

SCOPE

This RPSTL lists and authorizes spares and repair parts; special tools; special test, measurement, and diagnostic equipment (TMDE); and other special support equipment required for performance of field maintenance of the Collapsible Fabric Tank, Fuel Storage. It authorizes the requisitioning, issue, and disposition of spares, repair parts, and special tools as indicated by the source, maintenance, and recoverability (SMR) codes.

GENERAL

In addition to the Introduction Work Package, this RPSTL is divided into the following work packages:

1. Repair Parts List Work Packages. Work packages containing lists of spares and repair parts authorized by this RPSTL for use in the performance of maintenance. These work packages also include parts which must be removed for replacement of the authorized parts. Parts lists are composed of functional groups in ascending alphanumeric sequence, with the parts in each group listed in ascending figure and item number sequence. Sending units, brackets, filters, and bolts are listed with the component they mount on. Bulk materials are listed by item name in FIG. BULK at the end of the work packages.
2. Special Tools List Work Packages. Special Tools List Work Packages. Work packages containing lists of special tools, special TMDE, and special support equipment authorized by this RPSTL (as indicated by Basis of Issue (BOI) information in the DESCRIPTION AND USABLE ON CODE (UOC) column). Tools that are components of common tool sets and/or Class VII are not listed.
3. Cross-Reference Indexes Work Packages. There are two cross-reference indexes work packages in this RPSTL: the National Stock Number (NSN) Index work package, *and* the Part Number (P/N) Index work package. The National Stock Number Index work package refers you to the figure and item number. The Part Number Index work package refers you to the figure and item number.

EXPLANATION OF COLUMNS IN THE REPAIR PARTS LIST AND SPECIAL TOOLS LIST WORK PACKAGES

ITEM NO. (Column (1)). Indicates the number used to identify items called out in the illustration.

SMR CODE (Column (2)). The SMR code containing supply/requisitioning information, maintenance level category authorization criteria, and disposition instruction, as shown in the following breakout. This entry may be subdivided into 4 subentries, one for each service.

Table 1. SMR Code Explanation.

<u>Source Code</u>		<u>Maintenance Code</u>		<u>Recoverability Code</u>
<u>XX</u>		<u>XX</u>		<u>X</u>
1 st two positions: How to get an item.	3 rd position: Who can install, replace or use the item.	4 th position: Who can do complete repair* on the item.	5 th position: Who determines disposition action on unserviceable items.	

* Complete Repair: Maintenance capacity, capability, and authority to perform all corrective maintenance tasks of the "Repair" function in a use/user environment in order to restore serviceability to a failed item.

Source Code. The source code tells you how to get an item needed for maintenance, repair, or overhaul of an end item/equipment. Explanation of source codes follows:

Source Code**Application/Explanation**

PA
PB
PC
PD
PE
PF
PG
PH
PR
PZ

NOTE

Items coded PC are subject to deterioration.

Stock items; use the applicable NSN to request/requisition items with these source codes. They are authorized to the level indicated by the code entered in the third position of the SMR code.

KD
KF
KB

Items with these codes are not to be requested/requisitioned individually. They are part of a kit which is authorized to the maintenance level indicated in the third position of the SMR code. The complete kit must be requisitioned and applied.

MF - Made at Field
MH - Made at below depot/sustainment level
ML - Made at SRA
MD - Made at Depot
MG -Navy Only

Items with these codes are not to be requested/requisitioned individually. They must be made from bulk material which is identified by the part number in the DESCRIPTION AND USABLE ON CODE (UOC) column and listed in the bulk material group of the repair parts list in the RPSTL. If the item is authorized to you by the third position code of the SMR code, but the source code indicates it is made at a higher level, order the item from the higher level of maintenance.

AF-Assembled by field
AH-Assembled by below depot sustainment level
AL-Assembled by SRA
AD-Assembled by depot
AG-Navy only

Items with these codes are not to be requested/requisitioned individually. The parts that make up the assembled item must be requisitioned or fabricated and assembled at the level of maintenance indicated by the source code. If the third position code of the SMR code authorizes you to replace the item, but the source code indicates the item is assembled at a higher level, order the item from the higher level of maintenance.

XA

Do not requisition an XA-coded item. Order its next higher assembly. (Refer to the NOTE below.)

XB

If an XB item is not available from salvage, order it using CAGEC and part number.

XC

Installation drawings, diagrams, instruction sheets, field service drawings; identified by manufacturer's part number.

XD

Item is not stocked. Order an XD-coded item through local purchase or normal supply channels using the CAGEC and part number given, if no NSN is available.

NOTE

Cannibalization or controlled exchange, when authorized, may be used as a source of supply for items with the above source codes, except for those source coded "XA" or those aircraft support items restricted by requirements of AR 750-1.

Maintenance Code. Maintenance codes tell you the level(s) of maintenance authorized to use and repair support items. The maintenance codes are entered in the third and fourth positions of the SMR code as follows:

Third Position. The maintenance code entered in the third position tells you the lowest maintenance level authorized to remove, replace, and use an item. The maintenance code entered in the third position will indicate authorization to the following levels of maintenance.

Maintenance Code

Application/Explanation

F -	Field maintenance can remove, replace, and use the item.
H -	Below Depot Sustainment maintenance can remove, replace, and use the item.
L -	Specialized repair activity can remove, replace, and use the item.
G -	Afloat and ashore intermediate maintenance can remove, replace, and use the item (Navy only)
K -	Contractor facility can remove, replace, and use the item
Z -	Item is not authorized to be removed, replace, or used at any maintenance level
D -	Depot can remove, replace, and use the item.

*NOTE – Army may use C in the third position. However, for joint service publications, Army will use O.

Fourth Position. The maintenance code entered in the fourth position tells you whether or not the item is to be repaired and identifies the lowest maintenance level with the capability to do complete repair (perform all authorized repair functions).

NOTE

Some limited repair may be done on the item at a lower level of maintenance, if authorized by the Maintenance Allocation Chart (MAC) and SMR codes.

Maintenance Code

Application/Explanation

F -	Field is the lowest level that can do complete repair of the item.
H -	Below Depot Sustainment is the lowest level that can do complete repair of the item.
L -	Specialized repair activity (enter specialized repair activity or TASMG designator) is the lowest level that can do complete repair of the item.
D -	Depot is the lowest level that can do complete repair of the item.
G -	Both afloat and ashore intermediate levels are capable of complete repair of item. (Navy only)
K -	Complete repair is done at contractor facility
Z -	Nonreparable. No repair is authorized.
B -	No repair is authorized. No parts or special tools are authorized for maintenance of "B" coded item. However, the item may be reconditioned by adjusting, lubricating, etc., at the user level.

Recoverability Code. Recoverability codes are assigned to items to indicate the disposition action on unserviceable items. The recoverability code is shown in the fifth position of the SMR code as follows:

Recoverability

<u>Code</u>	<u>Application/Explanation</u>
Z –	Non-repairable item. When unserviceable, condemn and dispose of the item at the level of maintenance shown in 3rd position of SMR code.
F –	Reparable item. When uneconomically repairable, condemn and dispose of the item at the ASB level.
H –	Reparable item. When uneconomically repairable, condemn and dispose of the item at the general support level.
D –	Reparable item. When beyond lower level repair capability, return to depot. Condemnation and disposal of item not authorized below depot level.
L –	Reparable item. Condemnation and disposal not authorized below Depot level.
A –	Item requires special handling or condemnation procedures because of specific reasons (such as precious metal content, high dollar value, critical material, or hazardous material). Refer to appropriate manuals/directives for specific instructions.
G –	Field level repairable item. Condemn and dispose at either afloat or ashore intermediate levels. (Navy only)
K–	Reparable item. Condemnation and disposal to be performed at Contractor facility.

NSN (Column (3)). The NSN for the item is listed in this column.

CAGEC (Column (4)). The Commercial and Government Entity Code (CAGEC) is a five-digit code which is used to identify the manufacturer, distributor, or Government agency/activity that supplies the item.

PART NUMBER (Column (5)). Indicates the primary number used by the manufacturer (individual, company, firm, corporation, or Government activity), which controls the design and characteristics of the item by means of its engineering drawings, specifications standards, and inspection requirements to identify an item or range of items.

NOTE

When you use an NSN to requisition an item, the item you receive may have a different part number from the number listed.

DESCRIPTION AND USABLE ON CODE (UOC) (Column (6)). This column includes the following information:

1. The Federal item name and, when required, a minimum description to identify the item.
2. Part numbers for bulk materials are referenced in this column in the line item entry for the item to be manufactured/fabricated.
3. Hardness Critical Item (HCI). A support item that provides the equipment with special protection from electromagnetic pulse (EMP) damage during a nuclear attack.
4. The statement END OF FIGURE appears just below the last item description in column (6) for a given figure in both the repair parts list and special tools list work packages.

QTY (Column (7)). The QTY (quantity per figure column) indicates the quantity of the item used in the breakout shown on the illustration/figure, which is prepared for a functional group, subfunctional group, or an assembly. A "V" appearing in this column instead of a quantity indicates that the quantity is variable and the quantity may change from application to application.

EXPLANATION OF CROSS-REFERENCE INDEXES WORK PACKAGES FORMAT AND COLUMNS

1. National Stock Number (NSN) Index Work Package. NSN's in this index are listed in National Item Identification Number (NIIN) sequence.

STOCK NUMBER Column. This column lists the NSN in NIIN sequence. The NIIN consists of the last nine digits of the NSN. When using this column to locate an item, ignore the first 4 digits of the NSN. However, the complete NSN should be used when ordering items by stock number. For example, if the NSN is 4730-00-938-7997, the NIIN is 00-938-7997.

FIG. Column. This column lists the number of the figure where the item is identified/located. The figures are in numerical order in the repair parts and special tools list work packages.

ITEM Column. The item number identifies the item associated with the figure listed in the adjacent FIG. column. This item is also identified by the NSN listed on the same line.

2. Part Number (P/N) Index Work Package. Part numbers in this index are listed by part number in ascending alphanumeric sequence (vertical arrangement of letter and number combinations which places the first letter or digit of each group in order A through Z, followed by the numbers 0 through 9 and each following letter or digit in like order).

PART NUMBER Column. Indicates the part number assigned to the item.

FIG. Column. This column lists the number of the figure where the item is identified/located in the repair parts list and special tool list work packages.

ITEM Column. The item number is that number assigned to the item as it appears in the figure referenced in the adjacent figure number column.

SPECIAL INFORMATION

Fabrication Instructions. Bulk materials required to manufacture items are listed in the bulk material functional group of this RPSTL. Part numbers for bulk material are also referenced in the Description Column of the line item entry for the item to be manufactured/fabricated. Detailed fabrication instructions for items source coded to be manufactured or fabricated are found in TM 10-5430-267-13&P.

Index Numbers. Items which have the word BULK in the figure column will have an index number shown in the item number column. This index number is a cross-reference between the National Stock Number/Part Number Index and the bulk material list in the repair parts list work packages.

Associated Publications. N/A

Illustrations List. The illustrations in this RPSTL contain field authorized items. Illustrations published in TM 10-5430-267-13&P, that contain unit authorized items also appear in the RPSTL. The tabular list in the repair parts list work package contains only those parts coded "F" in the third position of the SMR code, therefore, there may be a break in the item number sequence.

HOW TO LOCATE REPAIR PARTS**1. When NSNs or Part Number is Not Known.**

First. Using the table of contents, determine the assembly group or subassembly group to which the item belongs. This is necessary since figures are prepared for assembly groups and subassembly groups, and listings are divided into the same groups.

Second. Find the figure covering the assembly group or subassembly group to which the item belongs.

Third. Identify the item on the figure and note the number(s).

Fourth. Look in the repair parts list work packages of the figure and item numbers. The NSNs and part numbers are on the same line as the associated item numbers.

2. When NSN is known.

First. If you have the NSN, look in the STOCK NUMBER column of the NSN index work package. The NSN is arranged in NIIN sequence. Note the figure and item number next to the NSN.

Second. Turn to the figure and locate the item number. Verify that the item is the one you are looking for.

3. When Part Number is known.

First. If you have the part number and not the NSN, look in the PART NUMBER column of the part number index work package. Identify the figure and item number.

Second. Look up the item on the figure in the applicable repair parts list work packages.

END OF TASK**END OF WORK PACKAGE**

**FIELD MAINTENANCE
TANK, FABRIC, COLLAPSIBLE, FUEL STORAGE 20,000 GALLON
TANK ASSEMBLY**

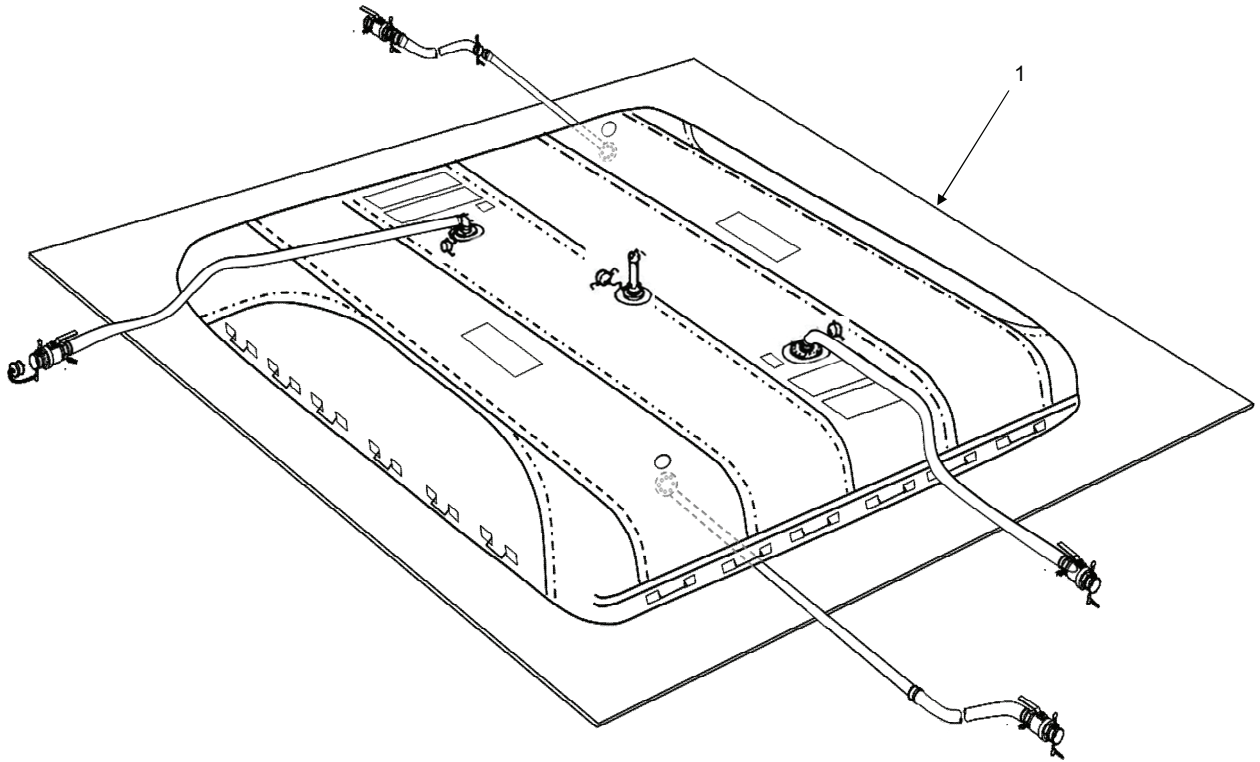

Figure 1. Tank Assembly.

(1) ITEM NO	(2) SMR CODE	(3) NSN	(4) CAGEC	(5) PART NUMBER	(6) DESCRIPTION AND USABLE ON CODE (UOC)	(7) QTY
-------------------	--------------------	------------	--------------	-----------------------	--	------------

GROUP 00 TANK ASSEMBLY

FIG. 1 TANK ASSEMBLY

1	PAFFF	5430-01-567-8840	1EMJ6	MPC-F-20K- AA	TANK, FABRIC, COLLAPSIBLE	1
---	-------	------------------	-------	------------------	---------------------------	---

END OF WORK PACKAGE

**FIELD MAINTENANCE
TANK, FABRIC, COLLAPSIBLE, FUEL STORAGE, 20,000 GALLON
FILLER/DISCHARGE HOSE ASSEMBLY**

1
2-7

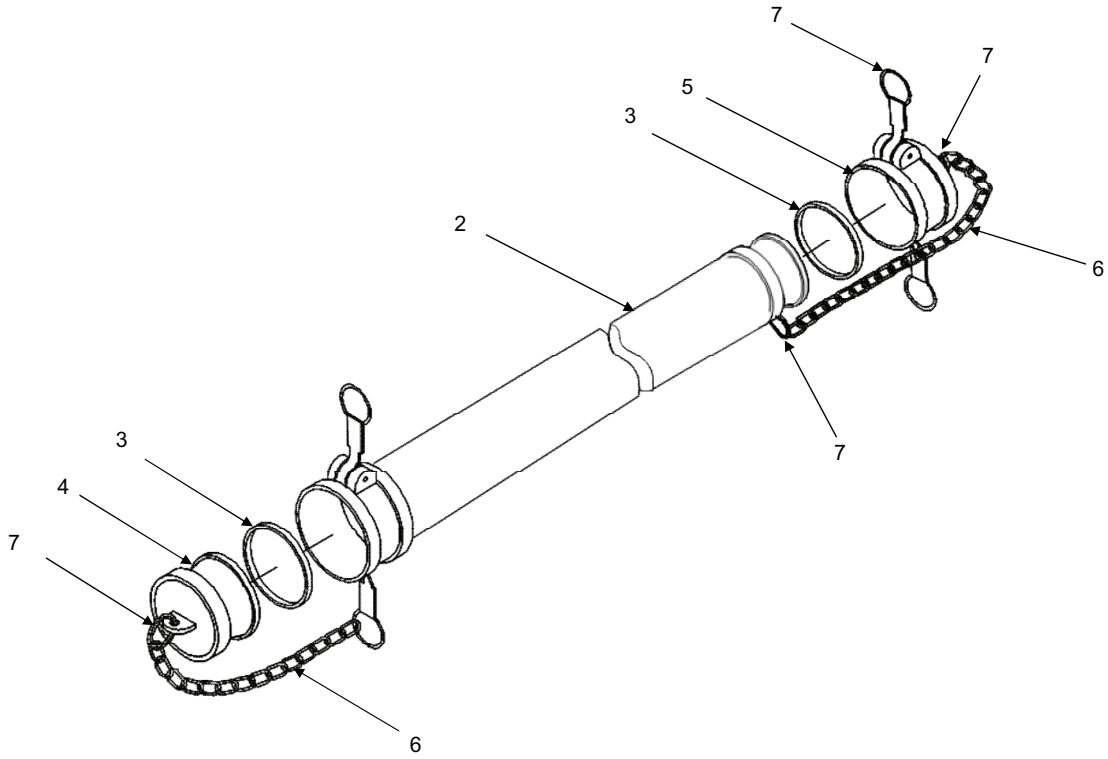

Figure 2. Filler/Discharge Hose Assembly.

(1) ITEM NO	(2) SMR CODE	(3) NSN	(4) CAGEC	(5) PART NUMBER	(6) DESCRIPTION AND USABLE ON CODE (UOC)	(7) QTY
GROUP 01						
FIG. 2 FILLER/DISCHARGE HOSE ASSEMBLY						
1	XDFFF		1EMJ6	MPC-FFDH-4- C	HOSE ASSEMBLY, 4 IN. X 12 FT, (10.16 CM x 304.8 CM) TAN	1
2	PAFZZ		63711	HA4-12-F	.HOSE, TAN, 4 IN. X 12 FT (10.16 CM x 365.76 CM)	1
3	PCFZZ		63711	G-CD-4-F	.GASKET	2
4	PAFZZ	4730-00-640-6188	58536	AA59326X19	.PLUG, QUICK DISCONNECT	1
5	PAFZZ	4730-00-640-6156	58536	AA59326IX-9	.CAP, QUICK DISCONNECT	1
6	MOFZZ	4010-01-526-4895	39428	3610T32	.CHAIN, WELDLESS	2
7	PAFZZ	5340-01-515-0537	39428	86805T38	.HOLDER, KEY	7

END OF FIGURE

**FIELD MAINTENANCE
TANK DRAIN BALL VALVE ASSEMBLY**

1
2-9

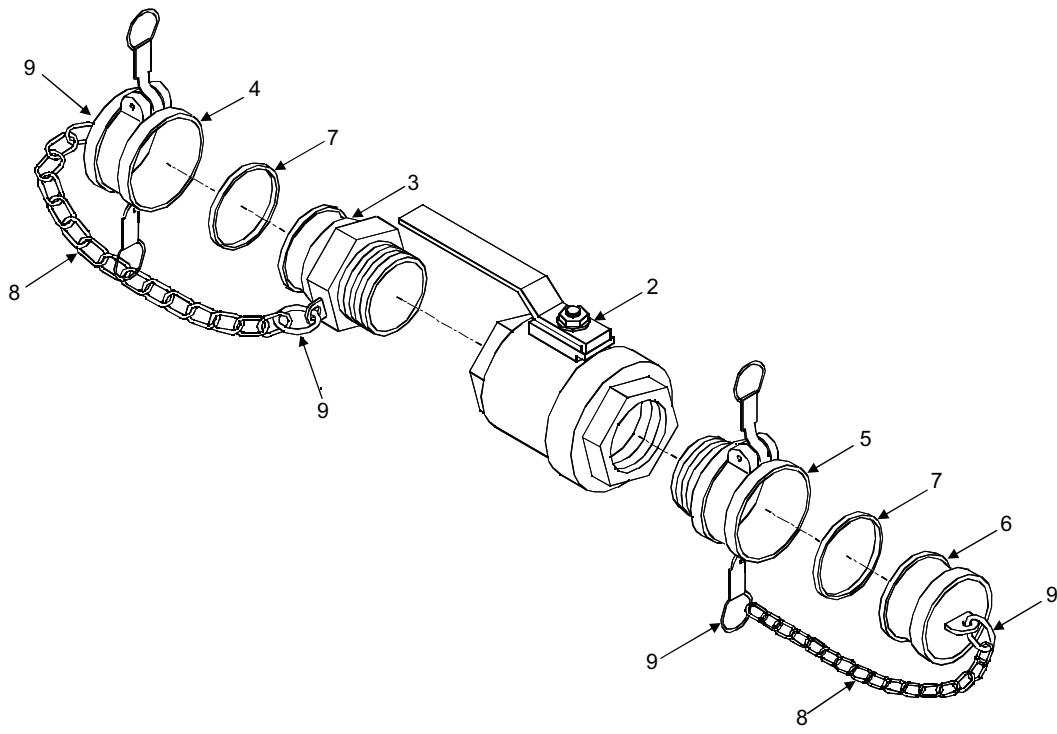

Figure 3. Tank Drain Ball Valve Assembly.

(1) ITEM NO	(2) SMR CODE	(3) NSN	(4) CAGEC	(5) PART NUMBER	(6) DESCRIPTION AND USABLE ON CODE (UOC)	(7) QTY
GROUP 02						
FIG. 3 TANK DRAIN BALL VALVE ASSEMBLY						
1	XDFFF		1EMJ6	MPC-FDV-2-B	BALL VALVE ASSEMBLY, 2 IN. (5.08 CM)	1
2	XDFZZ		63711	AHR-BRBV-2-F	.BALL VALVE, 2 IN. (5.08 CM)	1
3	PAFZZ	4730-00-938-7997	58536	AA59326/3A-6-A	.COUPLING HALF, QUICK DISCONNECT	1
4	PAFZZ	4730-00-649-9100	58536	AA59326IX16	.CAP, QUICK DISCONNECT	1
5	PAFZZ	4730-00-088-9285	58536	AA59326/7-6-A-1	.COUPLING HALF, QUICK DISCONNECT	2
6	PAFZZ	4730-00-915-5127	58536	AA59326X16	.PLUG, QUICK DISCONNECT	1
7	PCFZZ		63711	G-CD-2-F	.GASKET	2
8	MOFZZ	4010-01-526-4895	39428	3610T32	.CHAIN, WELDLESS	2
9	PAFZZ	5340-01-515-0537	39428	86805T38	.HOLDER, KEY	7

END OF FIGURE

**FIELD MAINTENANCE
TANK DRAIN HOSE ASSEMBLY, BOWL X CAM**

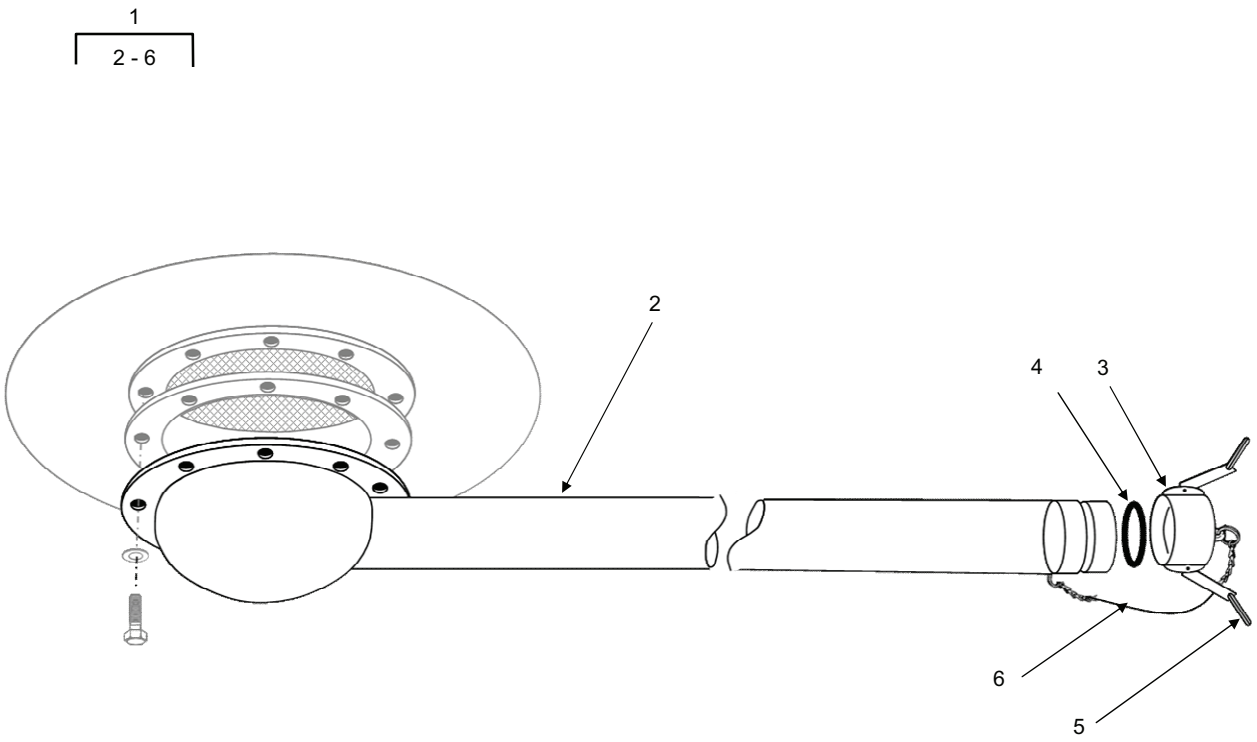

Figure 4. Tank Drain Hose Assembly, Bowl x Cam.

(1) ITEM NO	(2) SMR CODE	(3) NSN	(4) CAGEC	(5) PART NUMBER	(6) DESCRIPTION AND USABLE ON CODE (UOC)	(7) QTY
GROUP 03						
FIG. 4 TANK DRAIN HOSE ASSEMBLY, BOWL X CAM						
1	XDFFF		1EMJ6	MPC-FDH-2-D	HOSE ASSEMBLY, 2 IN. X 10 FT (5.08 CM x 3.05 M) WITH MALE AND MALE QD	1
2	XDFZZ		63711	PRF370-2X10-F	.HOSE ASSEMBLY X 10 FT (3.05 M) LONG WITH 2 IN. (5.08 CM) ALUMIN BOWL FITTING	1
3	PAFZZ	4730-00-649-9100	58536	AA59326IX16	.CAP, QUICK DISCONNECT	1
4	PCFZZ		63711	G-CD-2-F	.GASKET	1
5	PAFZZ	5340-01-515-0537	39428	86805T38	.HOLDER, KEY	4
6	MOFZZ	4010-01-526-4895	39428	3610T32	.CHAIN, WELDLESS	1

END OF WORK PACKAGE

**FIELD MAINTENANCE
TANK DRAIN HOSE ASSEMBLY, CAM X CAM**

1
2-7

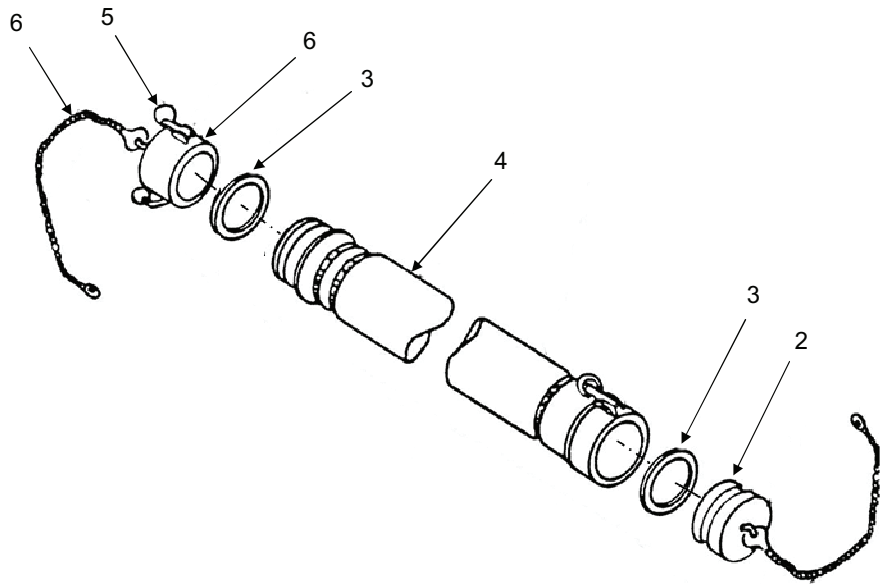

Figure 5. Tank Drain Hose Assembly, Cam x Cam.

(1) ITEM NO	(2) SMR CODE	(3) NSN	(4) CAGEC	(5) PART NUMBER	(6) DESCRIPTION AND USABLE ON CODE (UOC)	(7) QTY
-------------------	--------------------	------------	--------------	-----------------------	--	------------

GROUP 03

FIG. 5 TANK DRAIN HOSE
ASSEMBLY, CAM X CAM

1	XDFFF		1EMJ6	MPC-FDH-2-C	HOSE ASSEMBLY - FUEL 2 IN. X 10 FT (5.08 x 3.05 M)	1
2	PAFZZ	4730-00-915-5127	58536	AA59326X16	.PLUG, QUICK DISCONNECT	1
3	PCFZZ		63711	G-CD-2-F	.GASKET	2
4	XDFZZ		63711	HA2-10-F	.FUEL HOSE 10 FT (3.05 M) WITH 2 IN. (5.08 CM) ALUMIN FEMALE CAMLOCK FITTING	1
5	PAFZZ	5340-01-515-0537	39428	86805T38	.HOLDER, KEY	4
6	PAFZZ	4730-00-649-9100	58536	AA59326IX16	.CAP, QUICK DISCONNECT	1
7	MOFZZ	4010-01-526-4895	39428	3610T32	.CHAIN, WELDLESS	1

END OF WORK PACKAGE

FIELD MAINTENANCE
VENT PORT ASSEMBLY

1	2	9
2 - 17	3 - 8	10 - 17

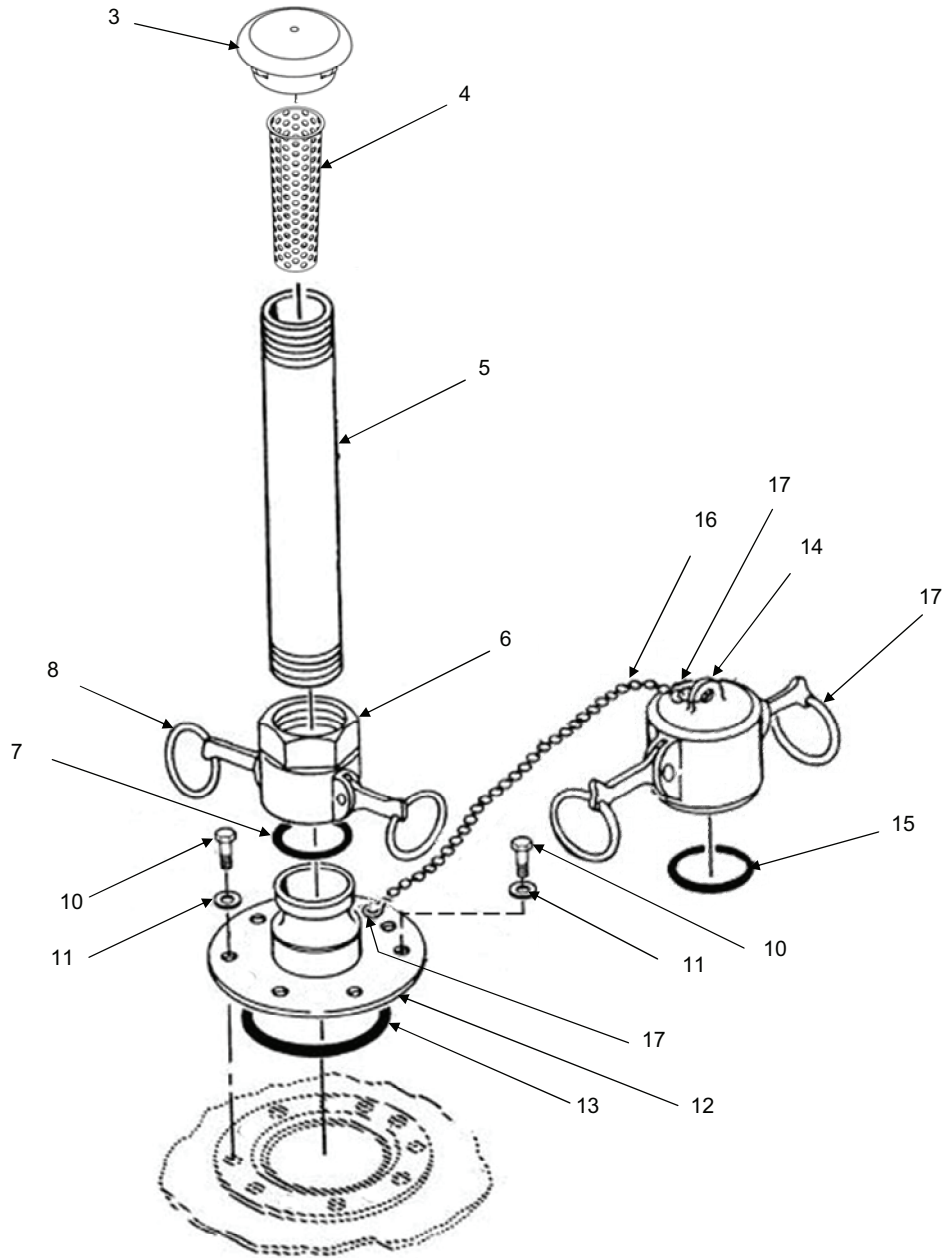

Figure 6. Vent Port Assembly.

(1) ITEM NO	(2) SMR CODE	(3) NSN	(4) CAGEC	(5) PART NUMBER	(6) DESCRIPTION AND USABLE ON CODE (UOC)	(7) QTY
GROUP 04						
FIG. 6 VENT PORT ASSEMBLY						
1	XDFFF		1EMJ6	MPC-FV-2-C	VENT PORT ASSEMBLY	1
2	PAFFF		1EMJ6	MPC-FV-2-E	..VENT STACK ASSEMBLY	1
3	XDFZZ		63711	MV-2	..PASSIVE VENT CAP	1
4	XDFZZ		63711	FA-2	..FLAME ARRESTOR	1
5	XDFZZ		63711	P-2-10	..PIPE, ALUMINUM, 2 IN. x 10 (5.08 x CM x 25.4 CM)	1
6	PAFZZ	4730-00-649-9103	58536	AA59326/5-6-A-1	..COUPLING HALF, QUICK DISCONNECT	1
7	PCFZZ		63711	G-CD-2-F	..GASKET	1
8	PAFZZ	5340-01-515-0537	39428	86805T38	..HOLDER, KEY	2
9	XDFFF		1EMJ6	MPC-FV-2-D	..VENT BOTTOM ASSEMBLY	1
10	PAFZZ	5305-00-068-0509	80204	B1821BH025 C125N	..SCREW, CAP, HEXAGON HEAD	8
11	PAFZZ	5310-01-232-7702	39428	98026A029	..WASHER, FLAT	8
12	PAFZZ	4730-01-416-1533	96906	MS27023-21	..COUPLING HALF, QUICK DISCONNECT	1
13	PCFZZ	5331-01-324-5262	81343	AS29513-250	..O-RING	1
14	PAFZZ	4730-00-649-9100	58536	AA59326IX16	..CAP, QUICK DISCONNECT	1
15	PCFZZ		63711	G-CD-2-F	..GASKET	1
16	MOFZZ	4010-01-526-4895	39428	3610T32	..CHAIN, WELDLESS	1
17	PAFZZ	5340-01-515-0537	39428	86805T38	..HOLDER, KEY	4

END OF FIGURE

**FIELD MAINTENANCE
FILLER/DISCHARGE ASSEMBLY**

1	5	9
2-4	6-8	10-25

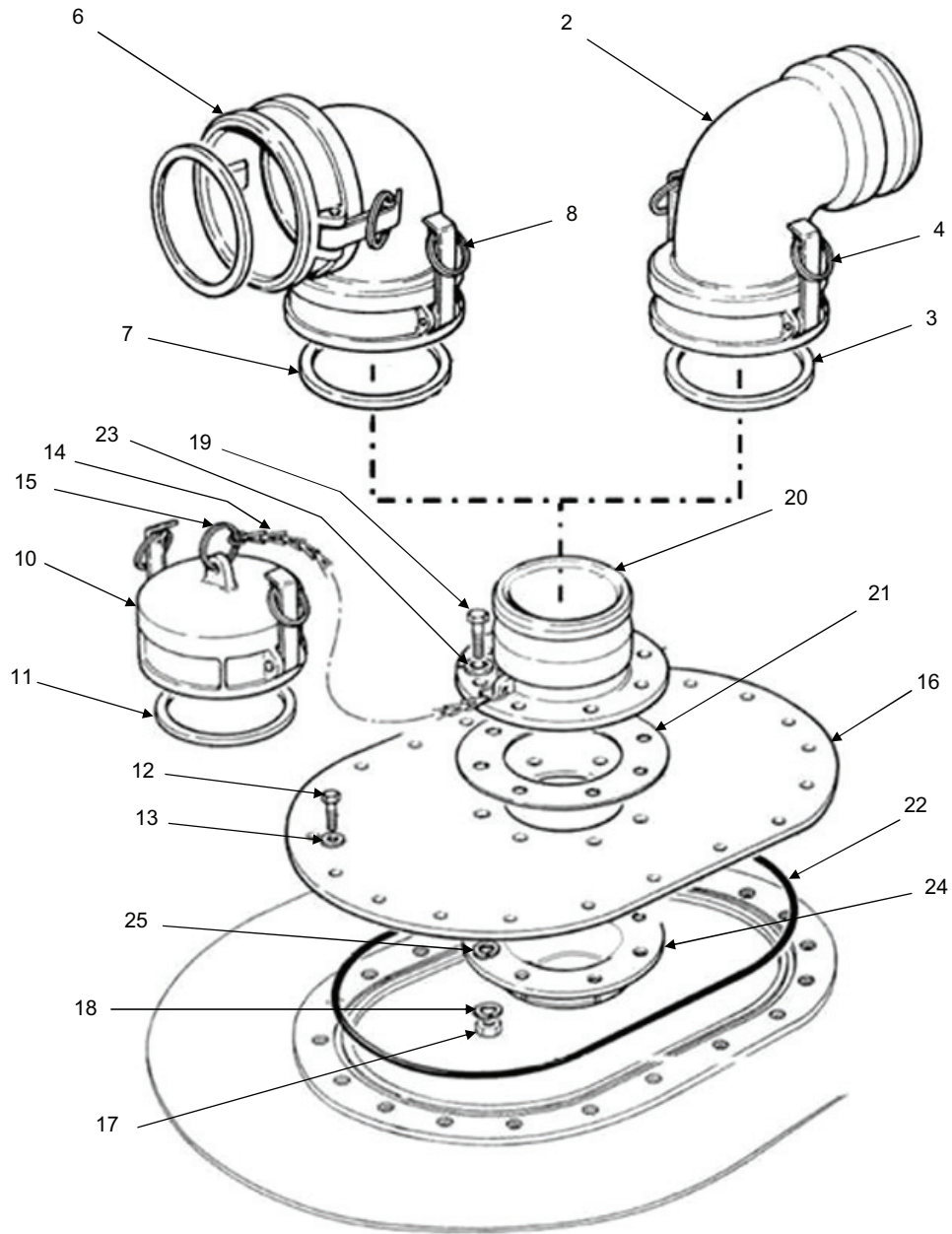

Figure 7. Filler/Discharge Assembly.

(1) ITEM NO	(2) SMR CODE	(3) NSN	(4) CAGEC	(5) PART NUMBER	(6) DESCRIPTION AND USABLE ON CODE (UOC)	(7) QTY
GROUP 05						
FIG. 7 FILLER/DISCHARGE ASSEMBLY						
1	XDFFF		1EMJ6	MPC-FE-4-MF	4 IN. (10.16 CM) X 90 DEG M/F FILLER ELBOW ASSY	1
2	XDFZZ		63711	EFM-90-4	.ELBOW, QUICK DISCONNECT, FEMALE x MALE, 4-IN. (10.16 CM)	1
3	PCFZZ		63711	G-CD-4-F	.GASKET	1
4	PAFZZ	5340-01-515-0537	39428	86805T38	.HOLDER, KEY	2
5	XDFFF		1EMJ6	MPC-FE-4-FF	4 IN. (10.16 CM) X 90 DEG F/F FILLER ELBOW ASSY	1
6	XDFZZ		63711	EFF-90-4	.ELBOW, QUICK DISCONNECT, FEMALE x FEMALE, 4-IN. (10.16 CM)	1
7	PCFZZ		63711	G-CD-4-F	.GASKET	1
8	PAFZZ	5340-01-515-0537	39428	86805T38	.HOLDER, KEY	4
9	XDFFF		1EMJ6	MPC-M-F- 1218-C	FILLER/DISCHARGE ASSEMBLY	1
10	PAFZZ	4730-00-640-6156	58536	AA59326IX-9	.CAP, QUICK DISCONNECT	1
11	PCFZZ		63711	G-CD-4-F	.GASKET	1
12	PAFZZ	5305-00-068-0509	80204	B1821BH025 C125N	.SCREW, CAP, HEXAGON HEAD	20
13	PAFZZ	5310-01-232-7702	39428	98026A029	.WASHER, FLAT	20
14	MOFZZ	4010-01-526-4895	39428	3610T32	.CHAIN, WELDLESS	1
15	PAFZZ	5340-01-515-0537	39428	86805T38	.HOLDER, KEY	4
16	XDFZZ		63711	CP-7	.PLATE, CLOSURE, COMPRESSION	1
17	PAFZZ	5310-01-519-2538	39428	93839A031	.NUT, PLAIN, HEXAGON	8
18	PAFZZ	5310-00-637-9541	05047	ASME- B18.21.1	.WASHER, LOCK	8
19	PAFZZ	5305-00-725-2317	80204	B1821BH038 C150N	.SCREW, CAP, HEXAGON HEAD	8
20	PAFZZ	4730-00-840-5347	58536	AA59326/4A- 4-A-1	.COUPLING HALF, QUICK DISCONNECT	1
21	PCFZZ		63711	G11-4-F	.GASKET	1
22	PCFZZ	5331-00-364-9862	81343	AS3578-383	.O-RING	1
23	PAFZZ	5310-01-534-7806	83259	90108A417	.WASHER, FLAT	8
24	XDFZZ		63711	SS-4-0-383	.SUCTION STUB, 4 IN. (10.16 CM)	1
25	PCFZZ	5330-00-874-3744	83259	7500-3-8	.GASKET	8
END OF FIGURE						

**FIELD MAINTENANCE
TANK DRAIN FITTING ASSEMBLY**

1
2-5

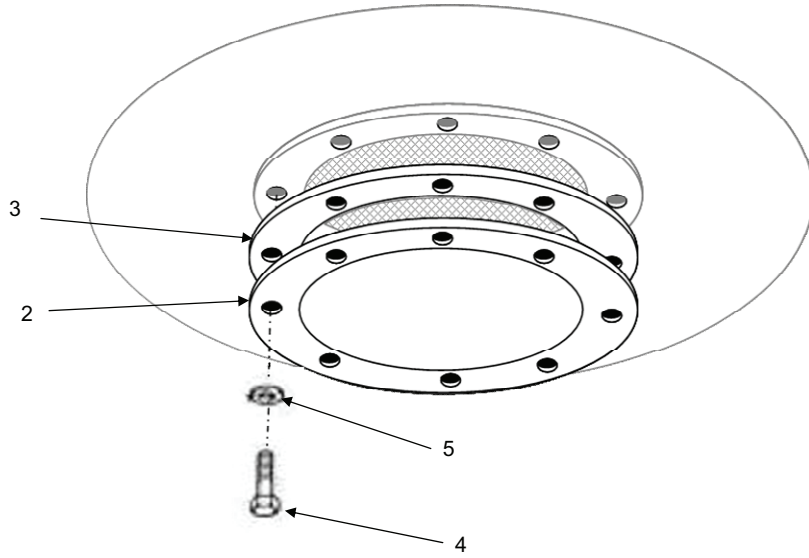

Figure 8. Tank Drain Fitting Assembly.

(1) ITEM NO	(2) SMR CODE	(3) NSN	(4) CAGEC	(5) PART NUMBER	(6) DESCRIPTION AND USABLE ON CODE (UOC)	(7) QTY
-------------------	--------------------	------------	--------------	-----------------------	--	------------

GROUP 06

FIG. 8 TANK DRAIN FITTING
ASSEMBLY

1	XDFFF		1EMJ6	MPC-FD-2-C	DRAIN ASSEMBLY, 2 IN. (5.08 CM)	1
2	XBFZZ		63711	BF-W8H-F	.BLIND FLANGE COVER, ALUMINUM	1
3	PAFZZ		63711	OG-DF-8F	.GASKET-BUNA-N, 1/8 IN. (0.3175 CM)	1
4	PAFZZ	5305-00-068-0509	80204	B1821BH025 C125N	.SCREW, CAP, HEXAGON HEAD	8
5	PAFZZ	5310-01-232-7702	39428	98026A029	.WASHER, FLAT	8

END OF FIGURE

FIELD MAINTENANCE
TANK ENVELOPE

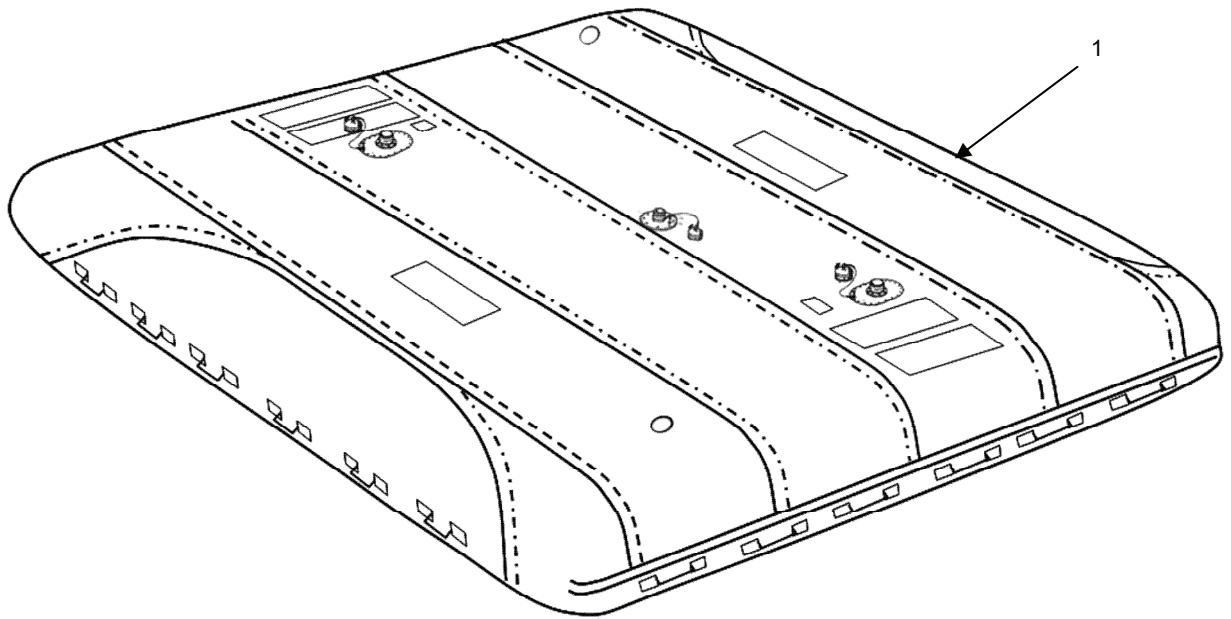

Figure 9. Tank Envelope.

(1) ITEM NO	(2) SMR CODE	(3) NSN	(4) CAGEC	(5) PART NUMBER	(6) DESCRIPTION AND USABLE ON CODE (UOC)	(7) QTY
-------------------	--------------------	------------	--------------	-----------------------	--	------------

GROUP 07

FIG. 9 TANK ENVELOPE

1	XBFZZ		1EMJ6	MPC-F-20K- TA	TANK, FABRIC, COLLAPS 20K GALLON, PETROLEUM	1
---	-------	--	-------	------------------	--	---

END OF FIGURE

**FIELD MAINTENANCE
BERM LINER ASSEMBLY**

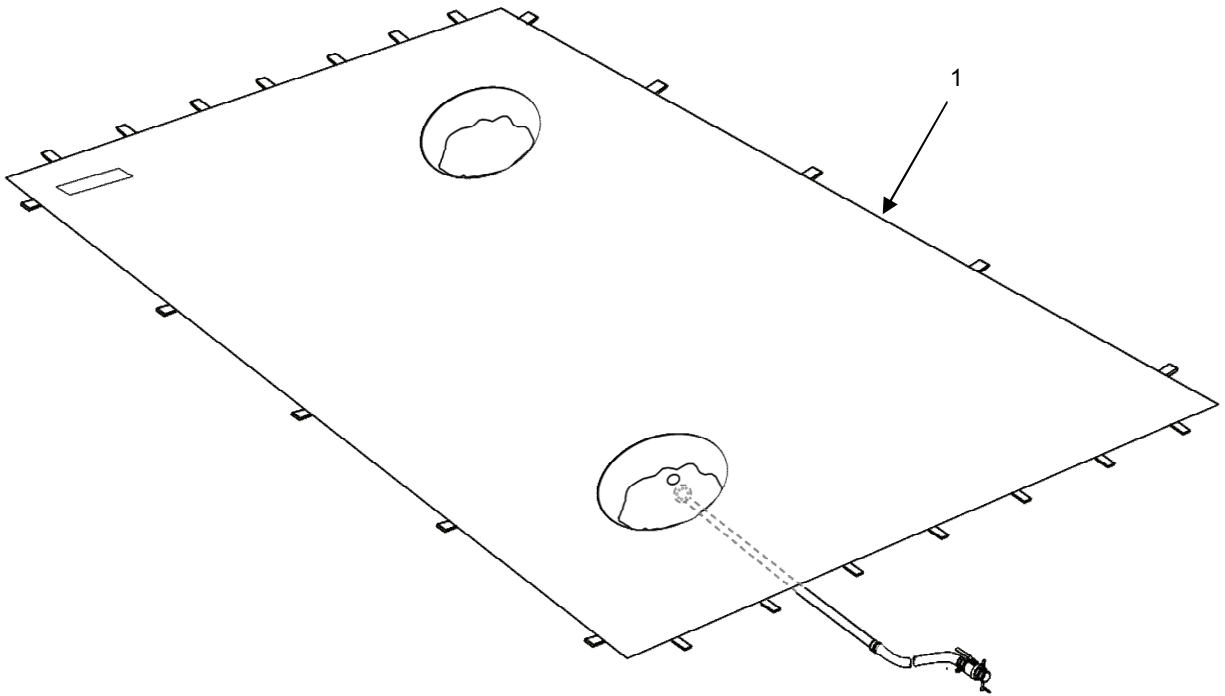

Figure 10. Berm Liner Assembly.

(1) ITEM NO	(2) SMR CODE	(3) NSN	(4) CAGEC	(5) PART NUMBER	(6) DESCRIPTION AND USABLE ON CODE (UOC)	(7) QTY
-------------------	--------------------	------------	--------------	-----------------------	--	------------

GROUP 08

FIG. 10 BERM LINER ASSEMBLY

1	PAFFF		1EMJ6	MPC-20K- BL-6565	BERM LINER ASSEMBLY	1
---	-------	--	-------	---------------------	---------------------	---

END OF FIGURE

**FIELD MAINTENANCE
BERM LINER DRAIN FITTING ASSEMBLY**

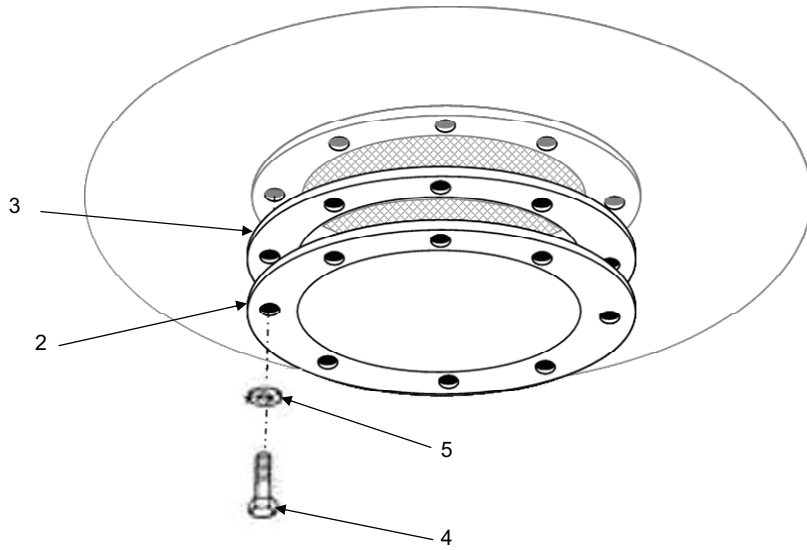
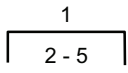

Figure 11. Berm Liner Drain Fitting Assembly.

(1) ITEM NO	(2) SMR CODE	(3) NSN	(4) CAGEC	(5) PART NUMBER	(6) DESCRIPTION AND USABLE ON CODE (UOC)	(7) QTY
GROUP 08						
FIG. 11 BERM LINER DRAIN FITTING ASSEMBLY						
1	XDFFF		1EMJ6	MPC-FD-2-D	TANK DRAIN FITTING ASSEMBLY	1
2	XBFZZ		63711	BF-W8H-F	.BLIND FLANGE COVER, ALUMINUM	1
3	PAFZZ		63711	OG-DF-8F	.GASKET-BUNA-N, 1/8 IN. (0.3175 CM)	1
4	PAFZZ	5305-00-068-0509	80204	B1821BH025 C125N	.SCREW, CAP, HEXAGON HEAD	8
5	PAFZZ	5310-01-232-7702	39428	98026A029	.WASHER, FLAT	8
END OF FIGURE						

**FIELD MAINTENANCE
BERM LINER DRAIN BALL VALVE ASSEMBLY**

1
2-9

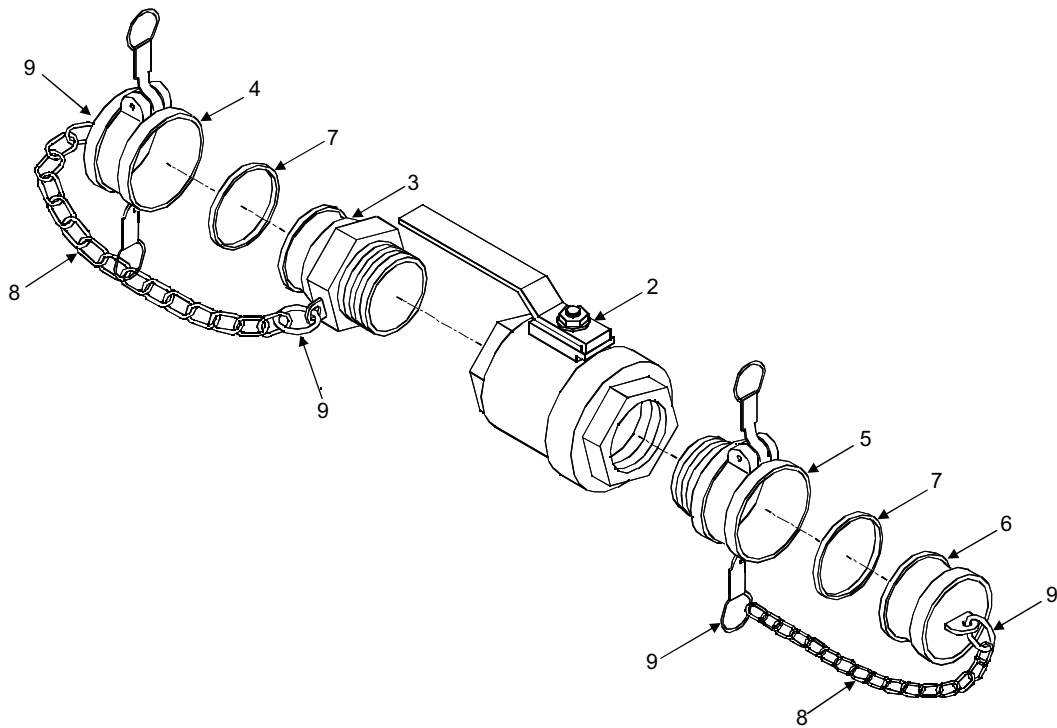

Figure 12. Berm Liner Drain Ball Valve Assembly.

(1) ITEM NO	(2) SMR CODE	(3) NSN	(4) CAGEC	(5) PART NUMBER	(6) DESCRIPTION AND USABLE ON CODE (UOC)	(7) QTY
GROUP 08						
FIG. 12 BERM LINER DRAIN BALL VALVE ASSEMBLY						
1	XDFFF		1EMJ6	MPC-FDV-2-B	BALL VALVE ASSEMBLY, 2 IN. (5.08 CM)	1
2	XDFZZ		63711	AHR-BRBV-2-F	.BALL VALVE, 2 IN. (5.08 CM)	1
3	PAFZZ	4730-00-938-7997	58536	AA59326/3A-6-A	.COUPLING HALF, QUICK DISCONNECT	1
4	PAFZZ	4730-00-649-9100	58536	AA59326IX16	.CAP, QUICK DISCONNECT	1
5	PAFZZ	4730-00-088-9285	58536	AA59326/7-6-A-1	.COUPLING HALF, QUICK DISCONNECT	2
6	PAFZZ	4730-00-915-5127	58536	AA59326X16	.PLUG, QUICK DISCONNECT	1
7	PCFZZ		63711	G-CD-2-F	.GASKET	2
8	MOFZZ	4010-01-526-4895	39428	3610T32	.CHAIN, WELDLESS	2
9	PAFZZ	5340-01-515-0537	39428	86805T38	.HOLDER, KEY	7

END OF FIGURE

**FIELD MAINTENANCE
BERM LINER DRAIN HOSE ASSEMBLY, BOWL X CAM**

1
2-6

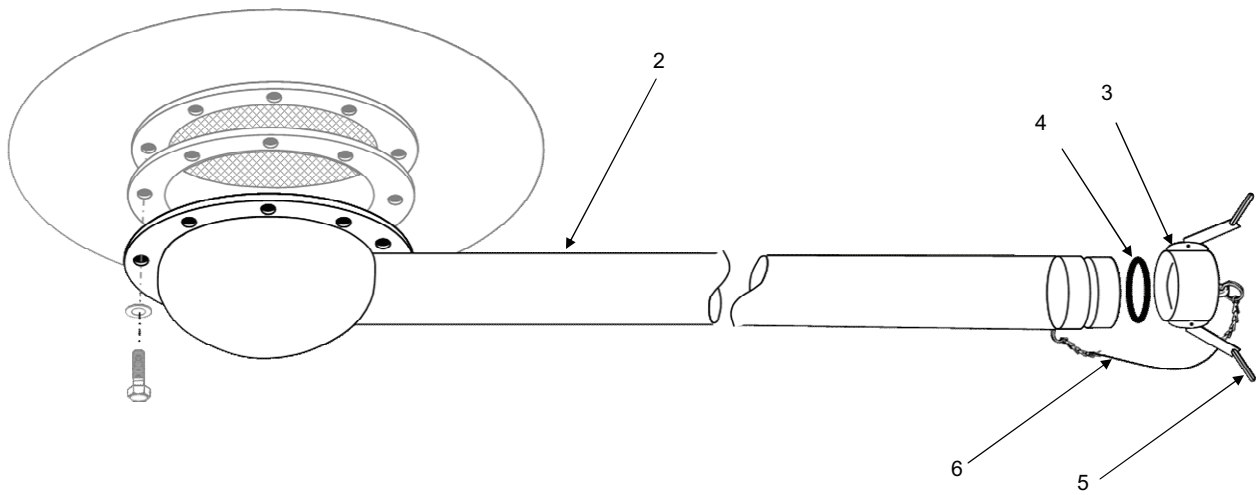

Figure 13. Berm Liner Drain Hose Assembly, Bowl x Cam.

(1) ITEM NO	(2) SMR CODE	(3) NSN	(4) CAGEC	(5) PART NUMBER	(6) DESCRIPTION AND USABLE ON CODE (UOC)	(7) QTY
-------------------	--------------------	------------	--------------	-----------------------	--	------------

GROUP 08

FIG. 13 BERM LINER DRAIN HOSE
ASSEMBLY, BOWL X CAM

1	PAFFF		1EMJ6	MPC-FDH-2-E	HOSE ASSEMBLY, DRAIN, 2 IN (5.08) X 20 FT (6.1 M), TAN	1
2	XBFZZ		63711	PRF370-2X20-F	.HOSE ASSEMBLY, 2 IN X 20 FT, TAN	1
3	PAFZZ	4730-00-649-9100	58536	AA59326IX16	.CAP, QUICK DISCONNECT	1
4	PCFZZ		63711	G-CD-2-F	.GASKET	1
5	PAFZZ	5340-01-515-0537	39428	86805T38	.HOLDER, KEY	4
6	MOFZZ	4010-01-526-4895	39428	3610T32	.CHAIN, WELDLESS	1

END OF FIGURE

**FIELD MAINTENANCE
BERM LINER DRAIN HOSE ASSEMBLY, CAM X CAM**

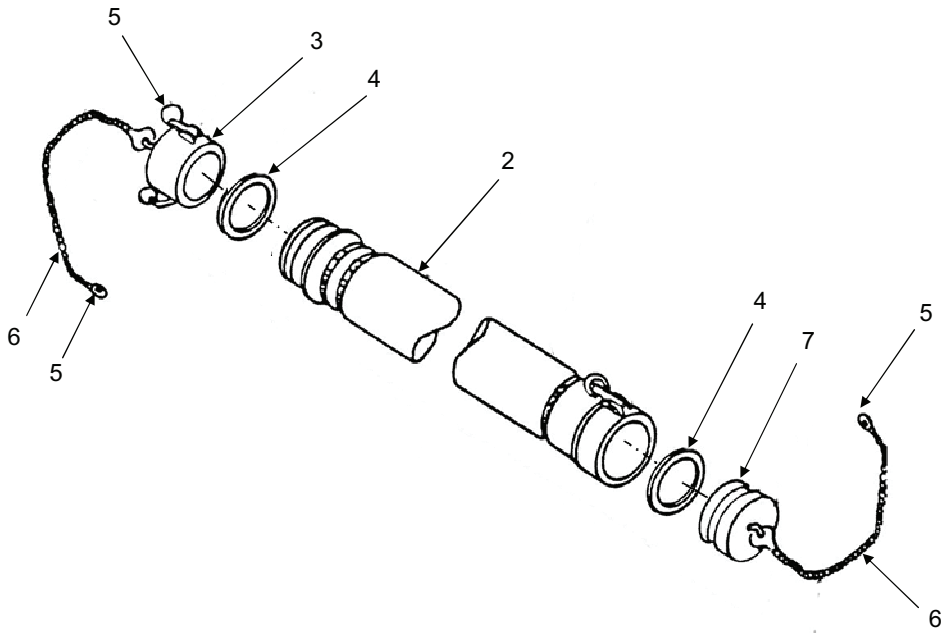
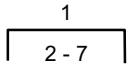

Figure 14. Berm Liner Drain Hose Assembly, Cam x Cam.

(1) ITEM NO	(2) SMR CODE	(3) NSN	(4) CAGEC	(5) PART NUMBER	(6) DESCRIPTION AND USABLE ON CODE (UOC)	(7) QTY
GROUP 08						
FIG. 14 BERM LINER DRAIN HOSE ASSEMBLY, CAM X CAM						
1	PAFFF		1EMJ6	MPC-FDH-2-F	HOSE ASSEMBLY, DRAIN, 2 IN (5.08) X 20 FT (6.1 M), TAN	1
2	XDFZZ		63711	HA2-20-F	.HOSE ASSEMBLY, 2 IN (5.08) X 20 FT, TAN	1
3	PAFZZ	4730-00-649-9100	58536	AA59326IX16	.CAP, QUICK DISCONNECT	1
4	PCFZZ		63711	G-CD-2-F	.GASKET	2
5	PAFZZ	5340-01-515-0537	39428	86805T38	.HOLDER, KEY	6
6	MOFZZ	4010-01-526-4895	39428	3610T32	.CHAIN, WELDLESS	2
7	PAFZZ	4730-00-915-5127	58536	AA59326X16	.PLUG, QUICK DISCONNECT	1

END OF FIGURE

**FIELD MAINTENANCE
BERM LINER**

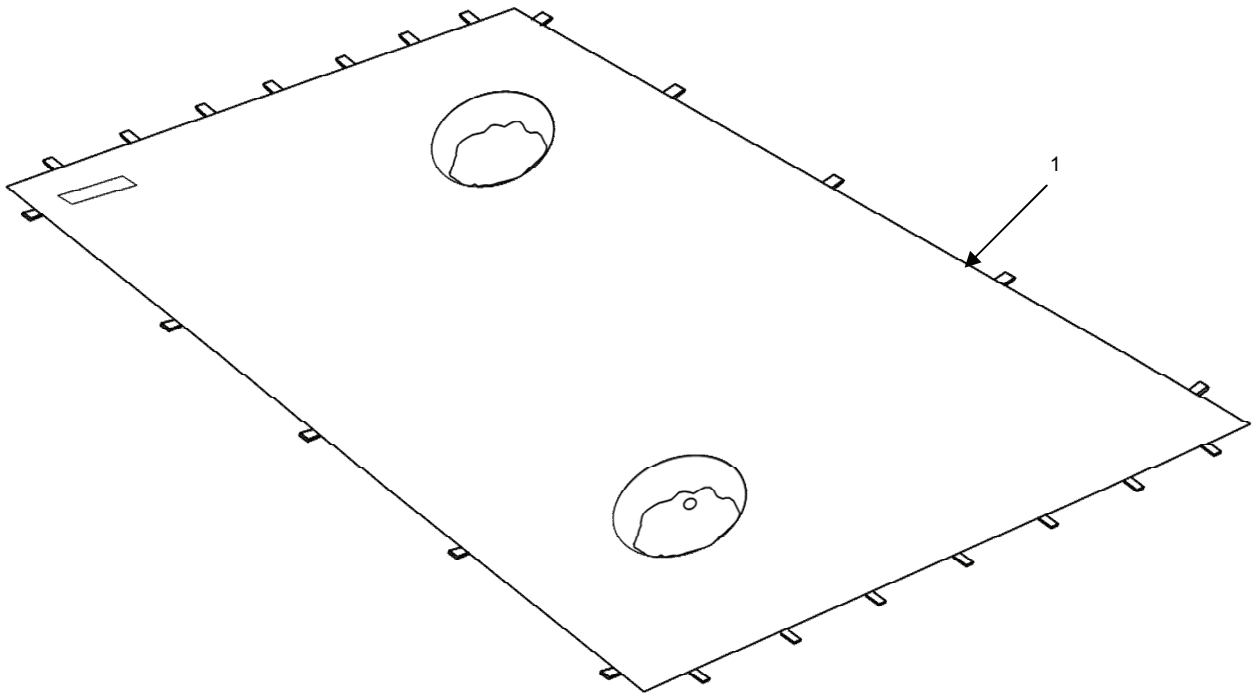

Figure 15. Berm Liner.

(1) ITEM NO	(2) SMR CODE	(3) NSN	(4) CAGEC	(5) PART NUMBER	(6) DESCRIPTION AND USABLE ON CODE (UOC)	(7) QTY
-------------------	--------------------	------------	--------------	-----------------------	--	------------

GROUP 08

FIG. 15 BERM LINER

1	PAFZZ		1EMJ6	MPC-R20K- BL-6565	BERM LINER	1
---	-------	--	-------	----------------------	------------	---

END OF FIGURE

**FIELD MAINTENANCE
REPAIR KIT, EMERGENCY**

1
2-10

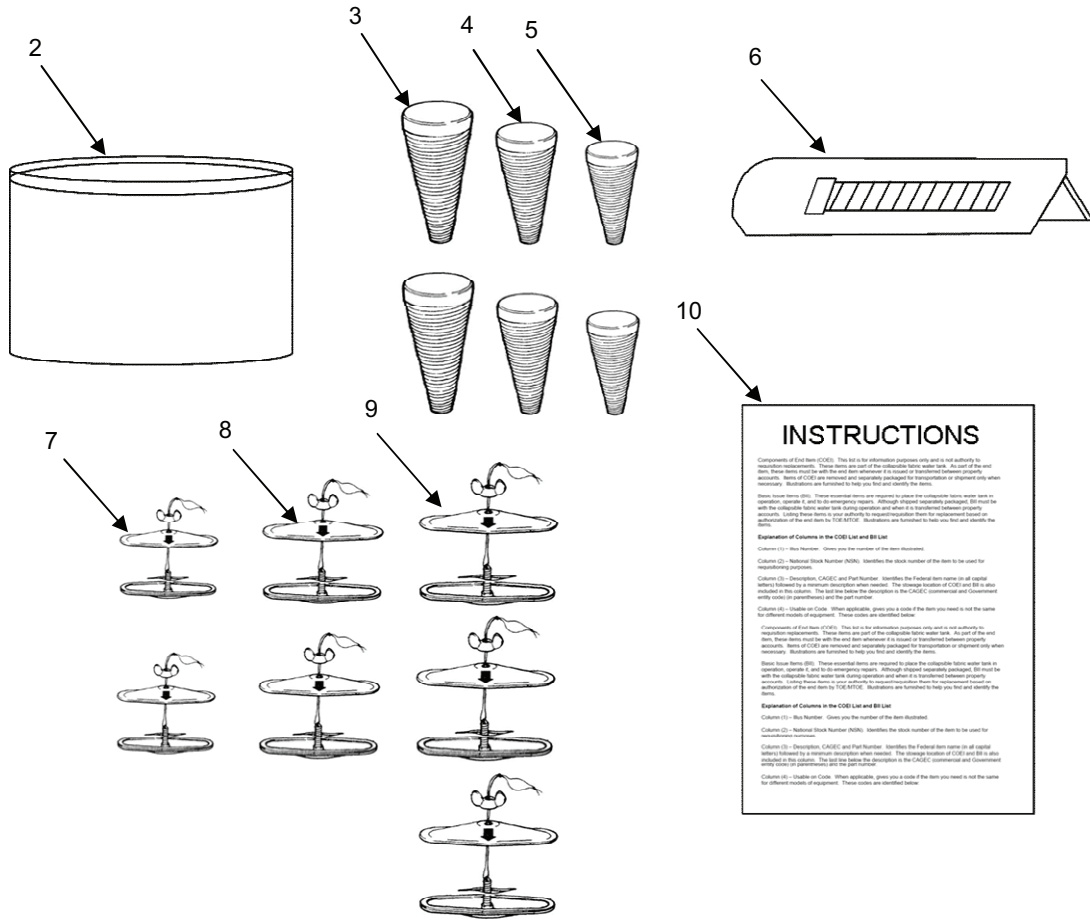

INSTRUCTIONS

Components of End Item (EIT). This list is for information purposes only and is not authority for procurement instructions. These items are part of the collapsible items water tank. As part of the end item, these items must be with the end item whenever it is loaded or transferred between primary locations. Items of CCE are removed and separately packaged for transportation or shipment only when necessary. Illustrations are furnished to help you find and identify the items.

Essential Items (EI). These essential items are required to place the collapsible items water tank in operation, operate it, and to do emergency repairs. Although shipped separately packaged, EI must be included. Listing these items is not authority for procurement instructions. Illustrations are furnished to help you find and identify the items.

Non-Essential Items (NEI). These non-essential items are required to do maintenance, repair, and to do emergency repairs. Although shipped separately packaged, NEI must be included. Listing these items is not authority for procurement instructions. Illustrations are furnished to help you find and identify the items.

Explanation of Columns in the CCE List and EI List

Column (1) - Item Number. Gives you the number of the item illustrated.

Column (2) - National Stock Number (NSN). Identifies the stock number of the item to be used for procurement purposes.

Column (3) - Description, CAUSE, and Part Number. Identifies the Federal item name in all capital letters followed by a descriptive description when needed. The storage location of CCE and EI is also included in this column. The last two letters of the description in the CAUSE, Commercial and Government items codes in parentheses and the part number.

Column (4) - Shaped or Code. When applicable, gives you a code if the item you need is not the same for different models of equipment. These codes are identified below.

Components of End Item (EIT). This list is for information purposes only and is not authority for procurement instructions. These items are part of the collapsible items water tank. As part of the end item, these items must be with the end item whenever it is loaded or transferred between primary locations. Items of CCE are removed and separately packaged for transportation or shipment only when necessary. Illustrations are furnished to help you find and identify the items.

Essential Items (EI). These essential items are required to place the collapsible items water tank in operation, operate it, and to do emergency repairs. Although shipped separately packaged, EI must be included. Listing these items is not authority for procurement instructions. Illustrations are furnished to help you find and identify the items.

Non-Essential Items (NEI). These non-essential items are required to do maintenance, repair, and to do emergency repairs. Although shipped separately packaged, NEI must be included. Listing these items is not authority for procurement instructions. Illustrations are furnished to help you find and identify the items.

Explanation of Columns in the CCE List and EI List

Column (1) - Item Number. Gives you the number of the item illustrated.

Column (2) - National Stock Number (NSN). Identifies the stock number of the item to be used for procurement purposes.

Column (3) - Description, CAUSE, and Part Number. Identifies the Federal item name in all capital letters followed by a descriptive description when needed. The storage location of CCE and EI is also included in this column. The last two letters of the description in the CAUSE, Commercial and Government items codes in parentheses and the part number.

Column (4) - Shaped or Code. When applicable, gives you a code if the item you need is not the same for different models of equipment. These codes are identified below.

Figure 16. Repair Kit, Emergency.

(1) ITEM NO	(2) SMR CODE	(3) NSN	(4) CAGEC	(5) PART NUMBER	(6) DESCRIPTION AND USABLE ON CODE (UOC)	(7) QTY
GROUP 09						
FIG. 16 REPAIR KIT, EMERGENCY						
1	KAFFF		1EMJ6	MPC-RK-FW-3	REPAIR KIT, COLLAPSIBLE EMERGENCY	1
2	PAFZZ		84583	2263-3-1B	.CONTAINER	1
3	PAFZZ		84583	2263-3-4	.PLUG, WOOD, 5/8 IN. (1.5875 CM)	1
4	PAFZZ		84583	2263-3-3	.PLUG, WOOD, 1 1/2 IN. (3.81 CM)	1
5	PAFZZ		84583	2263-3-2	.PLUG, WOOD, 2 IN. (5.08 CM)	1
6	PAFZZ		39428	3682A11	.KNIFE, UTILITY	1
7	PAFZZ	5342-00-720-8864	97403	13202E2870-1	.PATCH, MECHANICAL, FLEXIBLE SURFACE	1
8	PAFZZ	5342-00-720-8863	97403	13202E2870-2	.PATCH, MECHANICAL, FLEXIBLE SURFACE	1
9	PAFZZ	5342-00-720-8858	97403	13202E2870-3	.PATCH, MECHANICAL, FLEXIBLE SURFACE	2
10	XDFZZ		84583	2263-3-9	.INSTRUCTION SHEET, TYPE II/III	1

END OF WORK PACKAGE

**FIELD MAINTENANCE
NATIONAL STOCK NUMBER INDEX**

STOCK NUMBER	FIG.	ITEM	STOCK NUMBER	FIG.	ITEM
4010-01-526-4895	2	6	5310-01-519-2538	7	17
	3	8	5310-01-534-7806	7	23
	4	6	5330-00-874-3744	7	25
	5	7	5331-00-364-9862	7	22
	6	16	5331-01-324-5262	6	13
	7	14	5340-01-515-0537	2	7
	12	8		3	9
	13	6		4	5
	14	6		5	5
4730-00-088-9285	3	5		6	8
	12	5		6	17
4730-00-640-6156	2	5		7	4
	7	10		7	8
4730-00-640-6188	2	4		7	15
4730-00-649-9100	3	4		12	9
	4	3		13	5
	5	6		14	5
	6	14	5342-00-720-8858	16	9
	12	4	5342-00-720-8863	16	8
	13	3	5342-00-720-8864	16	7
	14	3	5430-01-567-8835	1	1
4730-00-649-9103	6	6	5430-01-567-8840	1	1
4730-00-840-5347	7	20			
4730-00-915-5127	3	6			
	5	2			
	12	6			
	14	7			
4730-00-938-7997	3	3			
	12	3			
4730-01-416-1533	6	12			
5305-00-068-0509	6	10			
	7	12			
	8	4			
	11	4			
5305-00-725-2317	7	19			
5310-00-637-9541	7	18			
5310-01-232-7702	6	11			
	7	13			
	8	5			
	11	5			

**FIELD MAINTENANCE
PART NUMBER INDEX**

PART NUMBER	FIG.	ITEM	PART NUMBER	FIG.	ITEM
13202E2870-1	16	7	AA59326/5-6-A-1	6	6
13202E2870-2	16	8	AA59326/7-6-A-1	3	5
13202E2870-3	16	9		12	5
2263-3-1B	16	2	AA59326IX16	3	4
2263-3-2	16	5		4	3
2263-3-3	16	4		5	6
2263-3-4	16	3		6	14
2263-3-9	16	10		12	4
3610T32	2	6		13	3
	3	8		14	3
	6	16	AA59326IX-9	2	5
	4	6		7	10
	5	7	AA59326X16	3	6
	7	14		12	6
	12	8		14	7
	13	6	AA59326X19	2	4
	14	6	AA59326X16	5	2
3682A11	16	6	AHR-BRBV-2-F	3	2
7500-3-8	7	25		12	2
86805T38	2	7	AS29513-250	6	13
	3	9	AS3578-383	7	22
	4	5	ASME-B18.21.1	7	18
	5	5	B1821BH025C125N	6	10
	6	8		7	12
	6	17		8	4
	7	4		11	4
	7	8	B1821BH038C150N	7	19
	7	15	BF-W8H-F	8	2
	12	9		11	2
	13	5	CP-7	7	16
	14	5	EFF-90-4	7	6
90108A417	7	23	EFM-90-4	7	2
93839A031	7	17	FA-2	6	4
98026A029	6	11	G11-4-F	7	21
	7	13	G-CD-2-F	3	7
	8	5		4	4
	11	5		6	7
AA59326/3A-6-A	3	3		12	7
	12	3		13	4
AA59326/4A-4-A-1	7	20		14	4

**FIELD MAINTENANCE
PART NUMBER INDEX**

PART NUMBER	FIG.	ITEM
G-CD-2-F	5	3
	6	15
G-CD-4-F	2	3
	7	3
	7	7
	7	11
HA2-10-F	5	4
HA2-20-F	14	2
HA4-12-F	2	2
MPC-20K-BL-6565	10	1
MPC-F-20K-AA	1	1
MPC-F-20K-TA	9	1
MPC-FD-2-C	8	1
MPC-FD-2-D	11	1
MPC-FDH-2-C	5	1
MPC-FDH-2-D	4	1
MPC-FDH-2-E	13	1
MPC-FDH-2-F	14	1
MPC-FDV-2-B	3	1
	12	1
MPC-FE-4-FF	7	5
MPC-FE-4-MF	7	1
MPC-FFDH-4-C	2	1
MPC-FV-2-C	6	1
MPC-FV-2-D	6	9
MPC-FV-2-E	6	2
MPC-M-W-1218-C	7	9
MPC-R20K-BL-6565	15	1
MPC-RK-FW-3	16	1
MS27023-21	6	12
MV-2	6	3
OG-DF-8F	8	3
	11	3
P-2-10	6	5
PRF370-2X10-F	4	2
	13	2
SS-4-0-383	7	24

CHAPTER 8

SUPPORTING INFORMATION
FOR
TANK, FABRIC, COLLAPSIBLE, FUEL STORAGE,
20,000 GALLON

**FIELD MAINTENANCE
TANK, FABRIC, COLLAPSIBLE, FUEL STORAGE, 20,000 GALLON
REFERENCES**

SCOPE

This work package lists all field manuals, forms, technical manuals and miscellaneous publications referenced in this manual.

ARMY REGULATIONS

AR 200-1 Environmental Protection and Enhancement
AR 700-138 Army Logistics Readiness and Sustainability

DA PAMPHLETS

DA PAM 750-8 The Army Maintenance Management System (TAMMS) Users Manual

FIELD MANUALS

FM 3-5 NBC Decontamination
FM 3-11.4 Multiservice Tactics, Techniques, and Procedures for Nuclear, Biological and
Chemical (NBC) Protection
FM 3-11.5 Multiservice Tactics, Techniques, and Procedures for Chemical, Biological,
Radiological and Nuclear Decontamination
FM 4-25.11 First Aid
FM 9-207 Operations and Maintenance of Ordnance Materiel in Cold Weather
FM 10-67-1 Concepts and Equipment of Petroleum Operations
FM 31-70 Basic Cold Weather Manual
FM 31-71 Northern Operations
FM 90-3 Desert Operations

FORMS

DA Form 2028 Recommended Changes to Publications and Blank Forms
DA Form 2404 Equipment Inspection and Maintenance Worksheet
DA Form 3643 Daily Issues of Petroleum Products
DA Form 5988-E Equipment Maintenance and Inspection Worksheet (Automated)
SF 361 Transportation Discrepancy Report
SF 368 Product Quality Deficiency Report

MISCELLANEOUS

ASME Y14.38-1999 The American Society of Mechanical Engineers Abbreviations and Acronyms
CTA 8-100 Common Table of Allowances, Army Medical Department Expendable/Durable
Items
CTA 50-970 Common Table of Allowances, Expendable/Durable Items (Except Medical,
Class V Repair Parts, and Heraldic Items)

SUPPLY CATALOGS

SC 4910-95-A81 Standard Automotive Tool Set (SATS)
SC 5180-95-N26 Tool Kit, General Mechanic's Automotive

TECHNICAL MANUALS

TM 750-244-6 Procedures for Destruction of Tank-Automotive Equipment to Prevent Enemy Use

END OF WORK PACKAGE

**FIELD MAINTENANCE
TANK, FABRIC, COLLAPSIBLE, FUEL STORAGE, 20,000 GALLON
MAINTENANCE ALLOCATION CHART (MAC) INTRODUCTION**

The Army Maintenance System MAC

This introduction provides a general explanation of all maintenance and repair functions authorized at the two maintenance levels under the Two-Level Maintenance System concept.

This MAC (immediately following the introduction) designates overall authority and responsibility for the performance of maintenance functions on the identified end item or component. The application of the maintenance functions to the end item or component shall be consistent with the capacities and capabilities of the designated maintenance levels, which are shown on the MAC in column (4) as:

Field - includes two subcolumns, Crew (C) and Maintainer (F).

Sustainment - includes two subcolumns, Below Depot (H) and Depot (D).

The maintenance to be performed at field and sustainment levels is described as follows:

1. Crew maintenance. The responsibility of a using organization to perform maintenance on its assigned equipment. It normally consists of inspecting, servicing, lubricating, adjusting, and replacing parts, minor assemblies, and subassemblies. The replace function for this level of maintenance is indicated by the letter "C" in the third position of the SMR code. A "C" appearing in the fourth position of the SMR code indicates complete repair is possible at the crew maintenance level.
2. Maintainer maintenance. Maintenance accomplished on a component, accessory, assembly, subassembly, plug-in unit, or other portion either on the system or after it is removed. The replace function for this level of maintenance is indicated by the letter "F" appearing in the third position of the SMR code. An "F" appearing in the fourth position of the SMR code indicates complete repair is possible at the field maintenance level. Items are returned to the user after maintenance is performed at this level.
3. Below depot sustainment. Maintenance accomplished on a component, accessory, assembly, subassembly, plug-in unit, or other portion either on the system or after it is removed. The replace function for this level of maintenance is indicated by the letter "H" appearing in the third position of the SMR code. An "H" appearing in the fourth position of the SMR code indicates complete repair is possible at the below depot sustainment maintenance level. Items are returned to the supply system after maintenance is performed at this level.
4. Depot sustainment. Maintenance accomplished on a component, accessory, assembly, subassembly, plug-in unit, or other portion either on the system or after it is removed. The replace function for this level of maintenance is indicated by the letter "D" or "K" appearing in the third position of the SMR code. Depot sustainment maintenance can be performed by either depot personnel or contractor personnel. A "D" or "K" appearing in the fourth position of the SMR code indicates complete repair is possible at the depot sustainment maintenance level. Items are returned to the supply systems after maintenance is performed at this level.

The tools and test equipment requirements table (immediately following the MAC) lists the tools and test equipment (both special tools and common tool sets) required for each maintenance function as referenced from the MAC.

The remarks table (immediately following the tools and test equipment requirements) contains supplemental instructions and explanatory notes for a particular maintenance function.

MAINTENANCE FUNCTIONS

Maintenance functions are limited to and defined as follows:

1. **Inspect.** To determine the serviceability of an item by comparing its physical, mechanical, and/or electrical characteristics with established standards through examination (e.g., by sight, sound, or feel). This includes scheduled inspection and gauging and evaluation of cannon tubes.
2. **Test.** To verify serviceability by measuring the mechanical, pneumatic, hydraulic, or electrical characteristics of an item and comparing those characteristics with prescribed standards on a scheduled basis, i.e., load testing of lift devices and hydrostatic testing of pressure hoses.
3. **Service.** Operations required periodically to keep an item in proper operating condition; e.g., to clean (includes decontaminate, when required), to preserve, to drain, to paint, or to replenish fuel, lubricants, chemical fluids, or gases. This includes scheduled exercising and purging of recoil mechanisms. The following are examples of service functions:
 - a. **Unpack.** To remove from packing box for service or when required for the performance of maintenance operations.
 - b. **Repack.** To return item to packing box after service and other maintenance operations.
 - c. **Clean.** To rid the item of contamination.
 - d. **Touch up.** To spot paint scratched or blistered surfaces.
 - e. **Mark.** To restore obliterated identification.
4. **Adjust.** To maintain or regulate, within prescribed limits, by bringing into proper position, or by setting the operating characteristics to specified parameters.
5. **Align.** To adjust specified variable elements of an item to bring about optimum or desired performance.
6. **Calibrate.** To determine and cause corrections to be made or to be adjusted on instruments of test, measuring, and diagnostic equipment used in precision measurement. Consists of comparisons of two instruments, one of which is a certified standard of known accuracy, to detect and adjust any discrepancy in the accuracy of the instrument being compared.
7. **Remove/Install.** To remove and install the same item when required to perform service or other maintenance functions. Install may be the act of emplacing, seating, or fixing into position a spare, repair part, or module (component or assembly) in a manner to allow the proper functioning of an equipment or system.
8. **Paint (ammunition only).** To prepare and spray color coats of paint so that the ammunition can be identified and protected. The color indicating primary use is applied, preferably, to the entire exterior surface as the background color of the item. Other markings are to be repainted as original so as to retain proper ammunition identification.
9. **Replace.** To remove an unserviceable item and install a serviceable counterpart in its place. "Replace" is authorized by the MAC and assigned maintenance level is shown as the third position code of the Source, Maintenance and Recoverability (SMR) code.
10. **Repair.** The application of the maintenance services, including fault location/troubleshooting, removal/installation, disassembly/assembly procedures, and maintenance actions to identify troubles and restore serviceability to an item by correcting specific damage, fault, malfunction, or failure in a part, subassembly, module (component or assembly), end item, or system.

MAINTENANCE FUNCTIONS – CONTINUED
NOTE

The following definitions are applicable to the “repair” maintenance function:

Services. Inspect, test, service, adjust, align, calibrate, and/or replace.

Fault location/troubleshooting. The process of investigating and detecting the cause of equipment malfunctioning; the act of isolating a fault within a system or Unit Under Test (UUT).

Disassembly/assembly. The step-by-step breakdown (taking apart) of a spare/functional group coded item to the level of its least component, that is assigned an SMR code for the level of maintenance under consideration (i.e., identified as maintenance significant).

Actions. Welding, grinding, riveting, straightening, facing, machining, and/or resurfacing.

11. Overhaul. That maintenance effort (service/action) prescribed to restore an item to a completely serviceable/operational condition as required by maintenance standards in appropriate technical publications. Overhaul is normally the highest degree of maintenance performed by the Army. Overhaul does not normally return an item to like new condition.
12. Rebuild. Consists of those services/actions necessary for the restoration of unserviceable equipment to a like new condition in accordance with original manufacturing standards. Rebuild is the highest degree of material maintenance applied to Army equipment. The rebuild operation includes the act of returning to zero those age measurements (e.g., hours/miles) considered in classifying Army equipment/components.

Explanation of Columns in the MAC

Column (1) Group Number. Column (1) lists Functional Group Code (FGC) numbers, the purpose of which is to identify maintenance significant components, assemblies, subassemblies, and modules with the Next Higher Assembly (NHA).

Column (2) Component/Assembly. Column (2) contains the item names of components, assemblies, subassemblies, and modules for which maintenance is authorized.

Column (3) Maintenance Function. Column (3) lists the functions to be performed on the item listed in column (2). (For a detailed explanation of these functions refer to “Maintenance Functions” outlined above).

Column (4) Maintenance Level. Column (4) specifies each level of maintenance authorized to perform each function listed in column (3), by indicating work time required (expressed as manhours in whole hours or decimals) in the appropriate subcolumn. This work time figure represents the active time required to perform that maintenance function at the indicated level of maintenance. If the number or complexity of the tasks within the listed maintenance function varies at different maintenance levels, appropriate work time figures are to be shown for each level. The work time figure represents the average time required to restore an item (assembly, subassembly, component, module, end item, or system) to a serviceable condition under typical field operating conditions. This time includes preparation time (including any necessary disassembly/assembly time), troubleshooting/fault location time, and quality assurance time in addition to the time required to perform the specific tasks identified for the maintenance functions authorized in the MAC.

MAINTENANCE FUNCTIONS – CONTINUED

The symbol designations for the various maintenance levels are as follows:

Field:

- C Crew maintenance
- F Maintainer maintenance

Sustainment:

- L Specialized Repair Activity (SRA)
- H Below depot maintenance
- D Depot maintenance

NOTE

The “L” maintenance level is not included in column (4) of the MAC. Functions to this level of maintenance are identified by work time figure in the “H” column of column (4), and an associated reference code is used in the REMARKS column (6). This code is keyed to the remarks and the SRA complete repair application is explained there.

Column (5) Tools and Equipment Reference Code. Column (5) specifies, by code, those common tool sets (not individual tools), common Test, Measurement and Diagnostic Equipment (TMDE), and special tools, special TMDE and special support equipment required to perform the designated function. Codes are keyed to the entries in the tools and test equipment table.

Column (6) Remarks Code. When applicable, this column contains a letter code, in alphabetical order, which is keyed to the remarks table entries.

Explanation of Columns in the Tools and Test Equipment Requirements

Column (1) – Tool or Test Equipment Reference Code. The tool or test equipment reference code correlates with a code used in Column (5) of the MAC.

Column (2) – Maintenance Level. The lowest level of maintenance authorized to use the tool or test equipment.

Column (3) – Nomenclature. Name or identification of the tool or test equipment.

Column (4) – National Stock Number (NSN). The NSN of the tool or test equipment.

Column (5) – Tool Number. The manufacturer’s part number.

Explanation of the Columns in the Remarks

Column (1) – Remarks Code. The code recorded in column (6) of the MAC.

Column (2) – Remarks. This column lists information pertinent to the maintenance function being performed as indicated in the MAC.

END OF WORK PACKAGE

**OPERATOR AND FIELD MAINTENANCE
TANK, FABRIC, COLLAPSIBLE, FUEL STORAGE, 20,000 GALLON
MAINTENANCE ALLOCATION CHART (MAC)**

MAINTENANCE ALLOCATION CHART

Table 1. Maintenance Allocation Chart (MAC).

(1) GROUP NUMBER	(2) COMPONENT/ ASSEMBLY	(3) MAINTENANCE FUNCTION	(4) MAINTENANCE LEVEL				(5) TOOLS AND EQUIPMENT REF CODE	(6) REMARKS CODE
			FIELD		SUSTAINMENT			
			CREW	MAINTAINER	BELOW DEPOT	DEPOT		
			C	F	H	D		
00	TANK ASSEMBLY							
01	FILLER/DISCHARGE HOSE ASSEMBLY	Inspect Service Repair	0.1 	0.1 0.2 0.2		1	A	
02	TANK DRAIN BALL VALVE ASSEMBLY	Inspect Service Repair	0.1 0.1	0.1 0.2 0.2		1	A B	
03	TANK DRAIN HOSE ASSEMBLY	Inspect Service Repair	0.1 0.1	0.1 0.2 0.2		1	A	
0301	TANK DRAIN HOSE ASSEMBLY, BOWL X CAM	Inspect Service Repair	0.1 0.1	0.1 0.2 0.2		1,2,3	A	
0302	TANK DRAIN HOSE ASSEMBLY, CAM X CAM	Inspect Service Repair	0.1 0.1	0.1 0.2 0.2		1	A	
04	VENT PORT ASSEMBLY	Inspect Service Repair	0.1 0.4	0.1 0.8 0.8		1,2	A B	
0401	CAP AND FLAME ARRESTOR ASSEMBLY, PASSIVE VENT	Inspect Service Repair	0.1 0.2	0.1 0.2 0.4		1	A	
0402	PIPE ASSEMBLY, VENT	Inspect Service Repair	0.1 0.2	0.1 0.2 0.2		1	A B	

Table 1. Maintenance Allocation Chart (MAC) – Continued.

(1) GROUP NUMBER	(2) COMPONENT/ ASSEMBLY	(3) MAINTENANCE FUNCTION	(4) MAINTENANCE LEVEL				(5) TOOLS AND EQUIPMENT REF CODE	(6) REMARKS CODE
			FIELD		SUSTAINMENT			
			CREW	MAINTAINER	BELOW DEPOT	DEPOT		
			C	F	H	D		
05	FILLER/DISCHARGE ASSEMBLY	Inspect	0.1	0.1			A	
		Service		0.8				
		Repair	0.4	0.8			1,2 B	
06	TANK DRAIN FITTING ASSEMBLY	Inspect	0.1	1.0			A	
		Service		0.5				
		Repair	0.4	0.5			1,2	
07	TANK ENVELOPE	Inspect	0.5					
		Service		1.0				
		Repair	0.5				1 C	
08	BERM LINER ASSEMBLY	Inspect	0.5				A	
		Service		1.0				
		Repair		3.0			1,2,3	
0801	BERM LINER DRAIN FITTING ASSEMBLY	Inspect	0.1	1.0			A	
		Service		0.5				
		Repair		3.0			1,2	
0802	BERM LINER DRAIN BALL VALVE ASSEMBLY	Inspect	0.1	0.1			A	
		Service		0.2				
		Repair	0.1	0.2			1 B	
0803	BERM LINER DRAIN HOSE ASSEMBLY, BOWL X CAM	Inspect	0.1	0.1			A	
		Service		0.2				
		Repair	0.1	0.1			1,2,3 C	
0804	BERM LINER DRAIN HOSE ASSEMBLY, CAM X CAM	Inspect	0.1	0.1			A	
		Service		0.2				
		Repair	0.1	0.1			1 C	
0805	BERM LINER	Replace		0.5				
09	REPAIR KIT, EMERGENCY	Inspect	0.1					
		Replace	0.5					

MAINTENANCE ALLOCATION CHART – CONTINUED

Table 2. Tools and Test Equipment Requirements for Tank Assembly.

TOOL OR TEST EQUIPMENT	MAINTENANCE LEVEL	NOMENCLATURE	NATIONAL STOCK NUMBER	TOOL NUMBER
1	F	Tool kit, general mechanic's	5180-00-177-7033	SC 5180-95-N26
2	F	Wrench, torque 0-175 ft•lb	5120-01-396-5751	1753LDF
3	F	Adapter, socket wrench, 3/8 in. female square end ½ in. male square end	5120-00-240-8703	B107.10M

Table 3. Remarks for Tank Assembly.

REMARK CODE	REMARKS
A	Operator inspection occurs with assembly intact. Field level inspection occurs after the assembly has been disassembled and cleaned.
B	Operator repair is limited to replacement of gaskets on quick-disconnect couplings.
C	Operator repair is limited to use of the clamps and plugs included with the emergency repair items.

END OF WORK PACKAGE

**FIELD MAINTENANCE
TANK, FABRIC, COLLAPSIBLE, FUEL STORAGE, 20,000 GALLON
COMPONENTS OF END ITEM (COEI) AND BASIC ISSUE ITEM (BII) LISTS**

INTRODUCTION**SCOPE**

This work package lists the COEI and BII for the Tank Assembly to aid in inventorying items for safe and efficient operation of the equipment.

GENERAL

The COEI and BII information is divided into the following lists:

Components of End Item (COEI). This list is for informational purposes only, and is not authority to requisition replacements. These items are part of the collapsible fabric fuel tank. As part of the end item, these items must be with the end item whenever it is issued or transferred between property accounts. Items of COEI are removed and separately packaged for transportation or shipment only when necessary. Illustrations are furnished to help you find and identify the items.

Basic Issue Items (BII). These essential items are required to place a Tank Assembly in operation, to operate it, and to do emergency repairs. Although shipped separately packaged, BII must be with the collapsible fabric fuel tank during operation and when it is transferred between property accounts. Listing these items is your authority to request/requisition them for replacement based on authorization of the end item by TOE/MTOE. Illustrations are furnished to help find and identify the items.

EXPLANATION OF COLUMNS IN THE COEI AND BII LIST

Column (1) Illus Number. Gives you the number of the item illustrated.

Column (2) National Stock Number (NSN). Identifies the stock number of the item to be used for requisitioning purposes.

Column (3) Description, Part Number/(CAGEC). Identifies the Federal item name (in all capital letters) followed by a minimum description when needed. The stowage location of COEI and BII is also included in this column. The last line below the description is the part number and the Commercial and Government Entity Code (CAGEC) (in parentheses).

Column (4) Usable On Code. When applicable, gives you a code if the item you need is not the same for different models of equipment.

Column (5) U/I. Unit of Issue (U/I) indicates the physical measurement or count of the item as issued per the National Stock Number shown in column (2).

Column (6) Qty Rqr. Indicates the quantity required.

COMPONENTS OF END ITEM (COEI) AND BASIC ISSUE ITEMS (BII) LISTS – CONTINUED

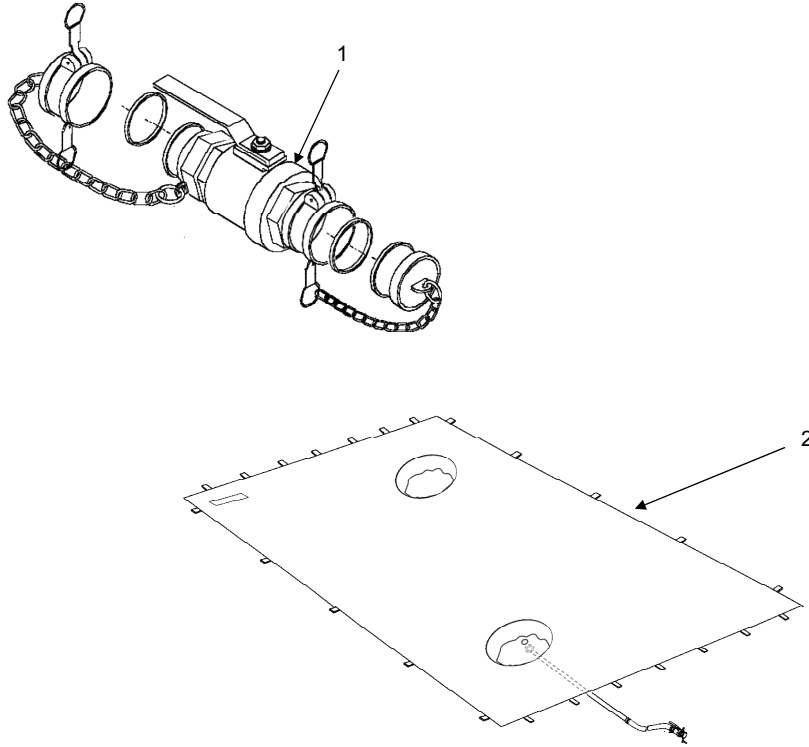

Table 1. Components of End Item (COEI).

(1) ILLUS NUMBER	(2) NATIONAL STOCK NUMBER (NSN)	(3) DESCRIPTION, PART NUMBER/(CAGEC)	(4) USABLE ON CODE	(5) U/I	(6) QTY RQR
1		Ball Valve Assembly, Tank and Berm Liner, 2 in. (5.08 cm) MPC-FDV-2-B (1EMJ6)		EA	2
2		Berm Liner, 20K Tank, MPC-20K-BL-6565 (1EMJ6)		EA	1

COMPONENTS OF END ITEM (COEI) AND BASIC ISSUE ITEMS (BII) LISTS – CONTINUED

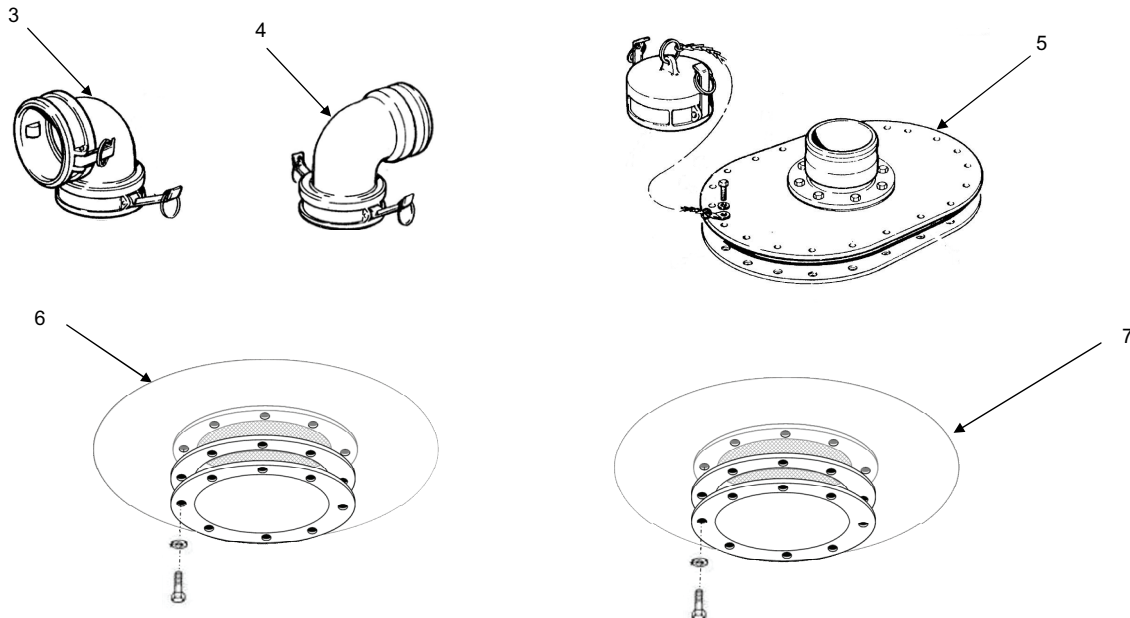

Table 1. Components of End Item (COEI) – Continued.

(1) ILLUS NUMBER	(2) NATIONAL STOCK NUMBER (NSN)	(3) DESCRIPTION, PART NUMBER/(CAGEC)	(4) USABLE ON CODE	(5) U/I	(6) QTY RQR
3		Elbow, Quick Disconnect, Female/Female, 4 in. (10.16 cm) EFF-90-4 (63711)		EA	1
4		Elbow, Quick Disconnect, Female/Male, 4 in. (10.16 cm) EMF-90-4 (63711)		EA	1
5		Filler/Discharge Assembly, MPC-M-F-1218-C (1EMJ6)		EA	2
6		Fitting Assembly, Berm Liner Drain MPC-FD-2-C (1EMJ6)		EA	2
7		Fitting Assembly, Tank Drain MPC-FD-2-C (1EMJ6)		EA	2

COMPONENTS OF END ITEM (COEI) AND BASIC ISSUE ITEMS (BII) LISTS – CONTINUED

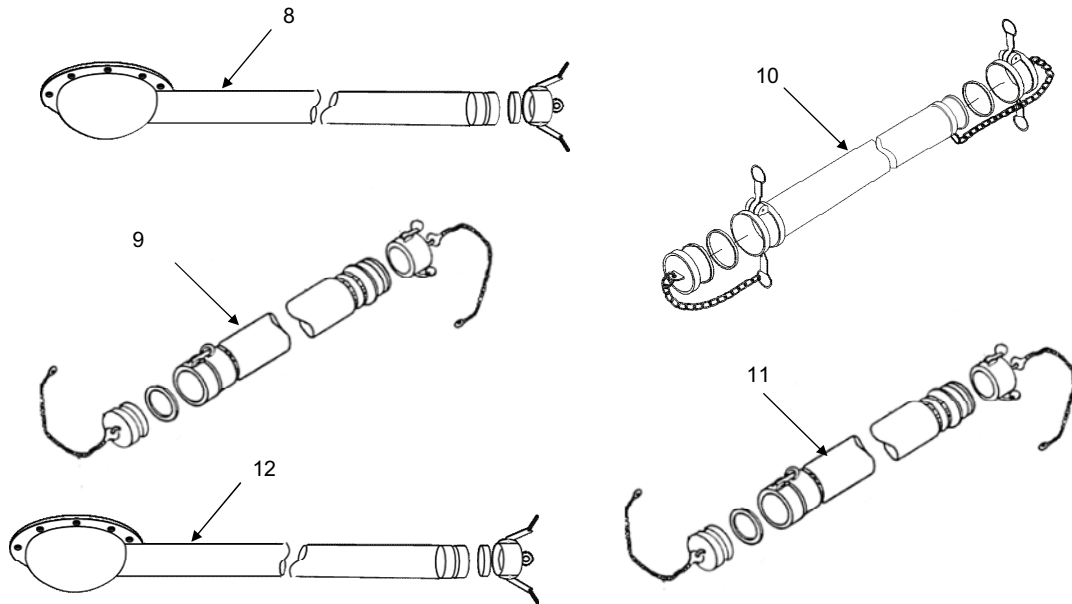

Table 1. Components of End Item (COEI) – Continued.

(1) ILLUS NUMBER	(2) NATIONAL STOCK NUMBER (NSN)	(3) DESCRIPTION, PART NUMBER/(CAGEC)	(4) USABLE ON CODE	(5) U/I	(6) QTY RQR
8		Hose Assembly, Berm Liner Drain 2-in. (5.08 cm) x 20-ft (3.05 m) MPC-FDH-2-E (1EMJ6)		EA	2
9		Hose Assembly, Berm Liner Drain 2-in. (5.08-cm) x 20-ft (3.05-m) MPC-FDH-2-F (1EMJ6)		EA	1
10		Hose Assembly, Filler/Discharge MPC-FFDH-4-C (1EMJ6)		EA	2
11		Hose Assembly, Tank Drain 2-in. (5.08 cm) x 10-ft (3.05 m) MPC-FDH-2-C (1EMJ6)		EA	1
12		Hose Assembly, Tank Drain 2-in. (5.08 cm) x 10-ft (3.05 m) PRF370-2X10-F (63711)		EA	1

COMPONENTS OF END ITEM (COEI) AND BASIC ISSUE ITEMS (BII) LISTS – CONTINUED

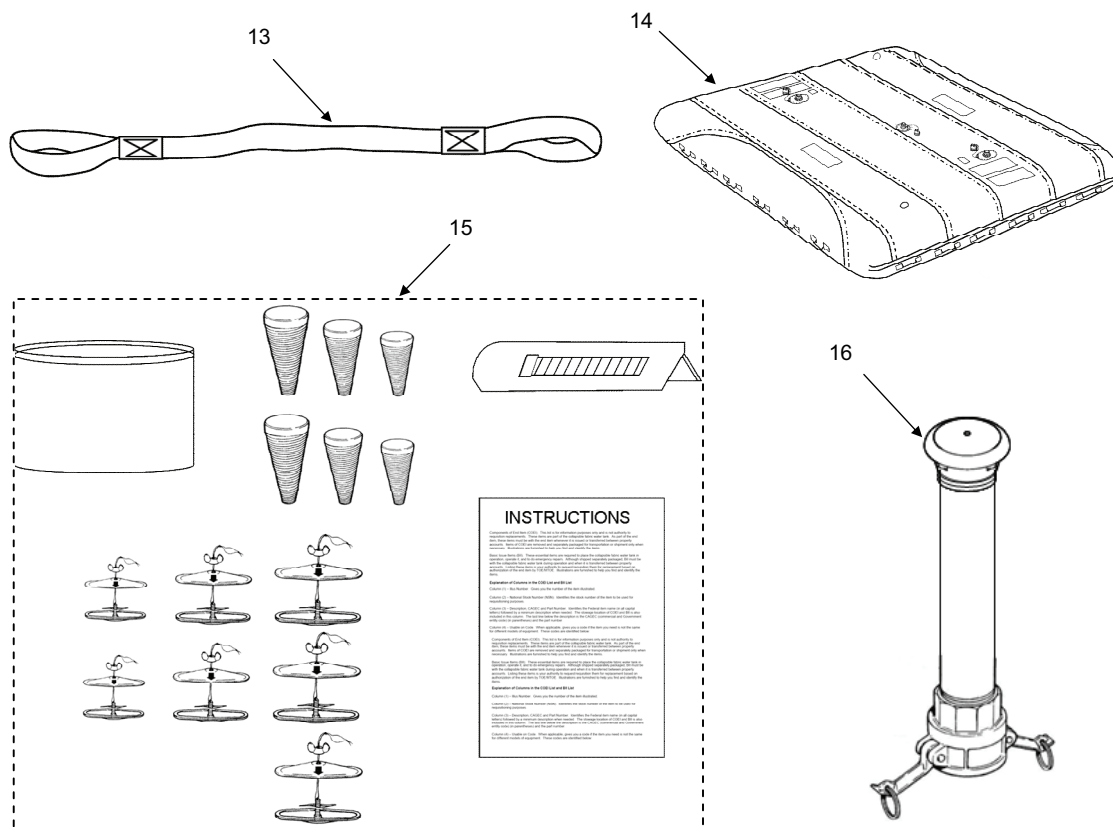

Table 1. Components of End Item (COEI) – Continued.

(1) ILLUS NUMBER	(2) NATIONAL STOCK NUMBER (NSN)	(3) DESCRIPTION, PART NUMBER/(CAGEC)	(4) USABLE ON CODE	(5) U/I	(6) QTY RQR
13		Lifting Sling, 2-in. (5.08 cm) x 15-ft (4.57 m) LMI-P-708-1 (1EMJ6)		EA	2
14	5430-01-473-2321	Tank, Fabric, Collapsible, 20K Gal MPC-F-20K-AA (97403)		EA	1
15		Emergency, Repair Items, Type III Repair Kit MPC-RK-FW-3 (1EMJ6)		EA	1
16		Vent Port Assembly MPC-FV-2-E (1EMJ6)		EA	1

COMPONENTS OF END ITEM (COEI) AND BASIC ISSUE ITEMS (BII) LISTS – CONTINUED

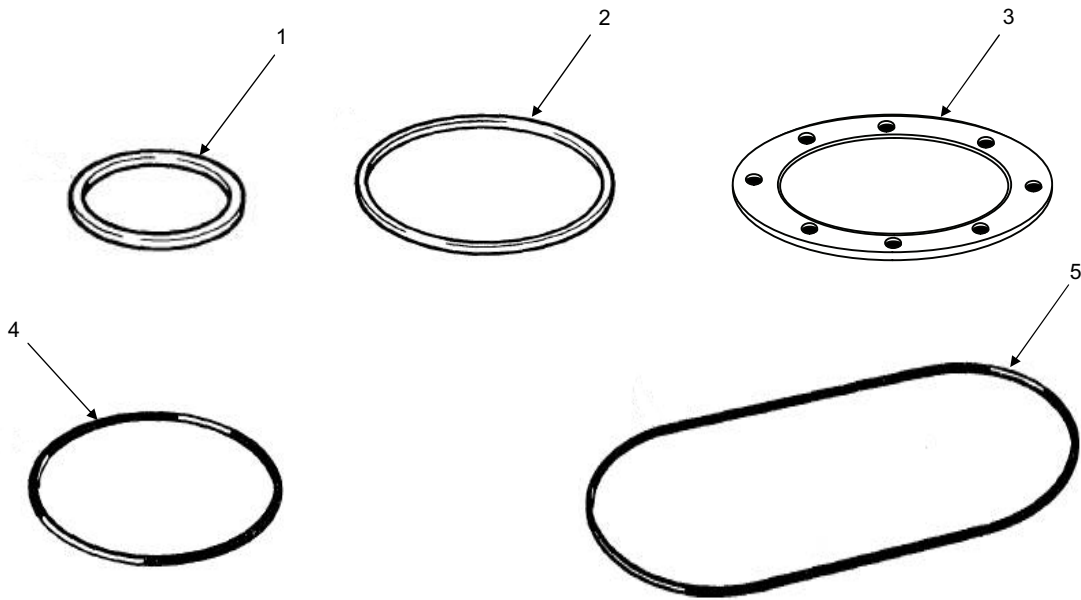

Table 2. On Board Spares.

(1) ILLUS NUMBER	(2) NATIONAL STOCK NUMBER (NSN)	(3) DESCRIPTION, PART NUMBER/(CAGEC)	(4) USABLE ON CODE	(5) U/I	(6) QTY RQR
1		Gasket G-CD-2-F (63711)			1
2		Gasket G-CD-4-F (63711)			1
3		Gasket G11-4-F (05476)			2
4	5331-00-324-5262	O-Ring AS29513-250 (81343)			3
5	5330-00-364-9862	O-Ring AS3578-383 (81343)			2

COMPONENTS OF END ITEM (COEI) AND BASIC ISSUE ITEMS (BII) LISTS – CONTINUED

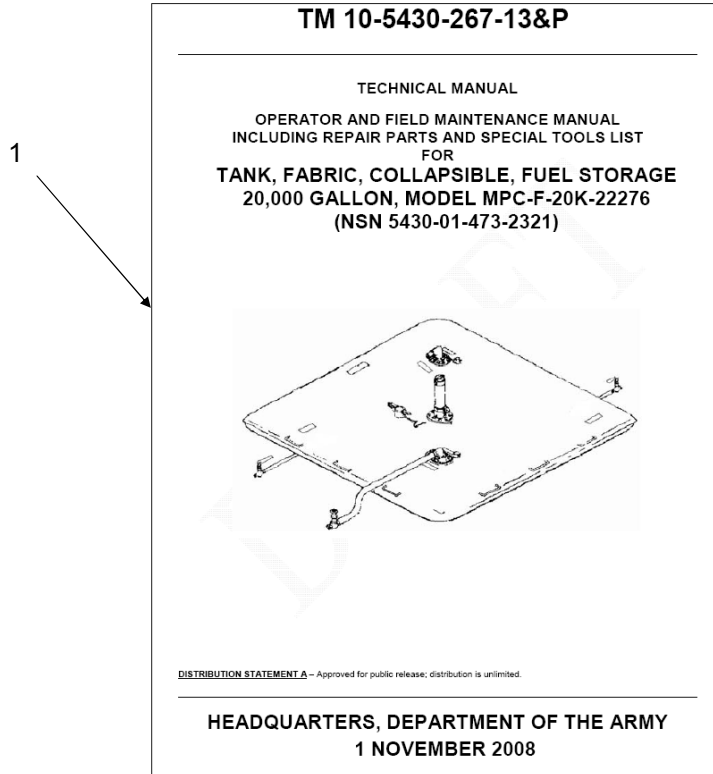

Table 3. Basic Issue Items (BII).

(1) ILLUS NUMBER	(2) NATIONAL STOCK NUMBER (NSN)	(3) DESCRIPTION, PART NUMBER/(CAGEC)	(4) USABLE ON CODE	(5) U/I	(6) QTY RQR
1		Technical Manual, Operator and Field Maintenance Including Repair Parts and Special Tools List TM 10-5430-267-13&P		EA	1

END OF WORK PACKAGE

**FIELD AND SUSTAINMENT MAINTENANCE
TANK, FABRIC, COLLAPSIBLE, FUEL STORAGE, 20,000 GALLON
EXPENDABLE AND DURABLE ITEMS LIST (EDIL)**

INTRODUCTION

Scope

This work package lists expendable and durable items that you will need to operate and maintain the Tank Assembly. This list is for information only and is not authority to requisition the listed items. These items are authorized to you by CTA 50-970, Expendable/Durable Items (Except Medical, Class V Repair Parts, and Heraldic Items), CTA 50-909, Field and Garrison Furnishings and Equipment or CTA 8-100, Army Medical Department Expendable/Durable Items.

Explanation of Columns in the Expendable/Durable Items List

Column (1) Item No. This number is assigned to the entry in the list and is referenced in the narrative instructions to identify the item (e.g., Use silicone compound (WP 0071, item 10)).

Column (2) Level. This column identifies the lowest level of maintenance that requires the listed item (C = Crew, F = Maintainer).

Column (3) National Stock Number (NSN). This is the NSN assigned to the item which you can use to requisition it.

Column (4) Item Name, Description, Part Number/(CAGEC). This column provides the other information you need to identify the item. The last line below the description is the part number and the Commercial and Government Entity Code (CAGEC) (in parentheses).

Column (5) U/I. Unit of Issue (U/I) code shows the physical measurement or count of an item, such as gallon, dozen, gross, etc.

Table 1. Expendable and Durable Items List (EDIL).

(1) ITEM NO.	(2) LEVEL	(3) NATIONAL STOCK NUMBER (NSN)	(4) ITEM NAME, DESCRIPTION, PART NUMBER/ (CAGEC)	(5) U/I
1	C	6850-01-474-2302	Cleaning Compound, Solvent (MIL-PRF-680 (81349))	GL
2	F	7930-00-531-9716	Detergent, General Purpose MIL-D-16791 (81349)	CN
3	C	6850-00-281-1985	Dry Cleaning Solvent A-A-59601 (58536)	BX
4	C	8415-01-147-6263	Gloves, Chemical and Oil Protective MIL-G-87066 (81349)	PR
5	C	4240-00-203-3804	Goggles, Industrial 3494187 (45152)	PR

Explanation of Columns in the Expendable/Durable Items List – CONTINUED
Table 1. Expendable and Durable Items List (EDIL) – Continued.

(1) ITEM NO.	(2) LEVEL	(3) NATIONAL STOCK NUMBER (NSN)	(4) ITEM NAME, DESCRIPTION, PART NUMBER/ (CAGEC)	(5) U/I
6	C	7920-00-205-1711	Rag, Wiping (80244)	BE
7	C	8030-00-543-4384	Sealing Compound AMS-S-7916 (81343)	PT
8	C	6850-00-880-7616	Silicone Compound SAE-A58660 (81343)	OZ
9	F	8030-00-889-3534	Tape, Anti-Seizing AA58092-2-1 (58536)	RO
10	C	7510-00-266-6709	Tape, Pressure Sensitive, Adhesive ASTM D-6123 (81346)	RO

END OF WORK PACKAGE

**OPERATOR AND FIELD MAINTENANCE
TANK, FABRIC, COLLAPSIBLE, FUEL STORAGE, 20,000 GALLON
MANDATORY REPLACEMENT PARTS LIST**

INTRODUCTION

This work package includes a list of all mandatory replacement parts referenced in the task initial setups and procedures. These are items that must be replaced during maintenance whether they have failed or not. This includes items based on usage intervals such as miles, time, rounds fired, etc.

Table 1. Mandatory Replacement Parts List (MRPL).

ITEM NO.	PART NUMBER/ (CAGEC)	NATIONAL STOCK NUMBER (NSN)	NOMENCLATURE	QTY
1	7500-3-8 (83259)	5330-00-874-3744	Gasket	8
2	AS29513-250 (81343)	5331-01-324-5262	O-Ring	1
3	AS3578-383 (81343)	5331-00-364-9862	O-Ring	1
4	ASME.B18.21.1 (05047)	5310-00-637-9541	Washer, Lock	8
5	G11-4-F (63711)		Gasket	1
6	G-CD-2-F (63711)		Gasket	10
7	G-CD-4-F (63711)		Gasket	7
8	OG-DF-8F (90906)		Gasket-Buna-N	2

END OF WORK PACKAGE

RECOMMENDED CHANGES TO PUBLICATIONS AND BLANK FORMS For use of this form, see AR 25-30; the proponent agency is ODISC4.						Use Part II (reverse) for Repair Parts and Special Tool Lists (RPSTL) and Supply Catalogs/Supply Manuals (SC/SM).	DATE Date you filled out this form.
TO: <i>(Forward to proponent of publication or form) (Include ZIP Code)</i> U.S. Army TACOM Life Cycle Management Command ATTN: AMSTA-LC-LMP/TECH PUBS 1 Rock Island Arsenal, Rock Island, IL 61299-7630						FROM: <i>(Activity and location) (Include ZIP Code)</i> Your mailing address	
PART I – ALL PUBLICATIONS (EXCEPT RPSTL AND SC/SM) AND BLANK FORMS							
PUBLICATION/FORM NUMBER TM 10-5430-267-13&P						DATE 15 April 2009	Title Oper & Field Maint Manual w/RPSTL for Tank, Fabric, Collapsible, Fuel Storage, 20,000 GAL Model MPC-F-20K-22276
ITEM NO.	PAGE NO.	PARA-GRAPH	LINE NO. *	FIGURE NO.	TABLE NO.	RECOMMENDED CHANGES AND REASON (Provide exact wording of recommended changes, if possible).	
						SAMPLE	
<i>*Reference to line numbers within the paragraph or subparagraph.</i>							
TYPED NAME, GRADE OR TITLE <i>Your Name</i>				TELEPHONE EXCHANGE/AUTOVON, PLUS EXTENSION		Signature <i>Your Signature</i>	

TO: (Forward direct to addressee listed in publication) U. S. Army TACOM Life Cycle Management Command ATTN: AMSTA-LC-LMPP/TECH PUBS 1 Rock Island Arsenal, Rock Island, IL 61299-7630	FROM: (Activity and location) (Include ZIP Code) Your address	DATE Date you filled out this form
--	---	--

PART II – REPAIR PARTS AND SPECIAL TOOL LISTS AND SUPPLY CATALOGS/SUPPLY MANUALS

PUBLICATION NUMBER TM 10-5430-267-13&P	DATE 15 April 2009	TITLE Oper & Field Maint Manual w/RPSRL Tank, Fabric, 20K Gal, MPC-F-20K-22276
--	------------------------------	--

PAGE NO.	COLM NO.	LINE NO.	NATIONAL STOCK NUMBER	REFERENCE NO.	FIGURE NO.	ITEM NO.	TOTAL NO. OF MAJOR ITEMS SUPPORTED	RECOMMENDED ACTION
SAMPLE								

PART III – REMARKS (Any general remarks or recommendations, or suggestions for improvement of publications and blank forms. Additional blank sheets may be used if more space is needed.)

TYPED NAME, GRADE OR TITLE Your Name	TELEPHONE EXCHANGE/AUTOVON, PLUS EXTENSION	SIGNATURE Your Signature
--	---	------------------------------------

TO: (Forward direct to addressee listed in publication) U. S. Army TACOM Life Cycle Management Command ATTN: AMSTA-LC-LMPP/TECH PUBS 1 Rock Island Arsenal, Rock Island, IL 61299-7630	FROM: (Activity and location) (Include ZIP Code)	DATE
--	---	-------------

PART II – REPAIR PARTS AND SPECIAL TOOL LISTS AND SUPPLY CATALOGS/SUPPLY MANUALS

PUBLICATION NUMBER TM 10-5430-267-13&P				DATE 15 April 2009			TITLE Oper & Field Maint Manual w/RPSTL for Tank, Fabric, 20K GAL, Model MPC-F-20K-22276	
PAGE NO.	COLM NO.	LINE NO.	NATIONAL STOCK NUMBER	REFERENCE NO.	FIGURE NO.	ITEM NO.	TOTAL NO. OF MAJOR ITEMS SUPPORTED	RECOMMENDED ACTION

PART III – REMARKS (Any general remarks or recommendations, or suggestions for improvement of publications and blank forms. Additional blank sheets may be used if more space is needed.)

TYPED NAME, GRADE OR TITLE	TELEPHONE EXCHANGE/AUTOVON, PLUS EXTENSION	SIGNATURE
----------------------------	--	-----------

RECOMMENDED CHANGES TO PUBLICATIONS AND BLANK FORMS						Use Part II (reverse) for Repair Parts and Special Tool Lists (RPSTL) and Supply Catalogs/Supply Manuals (SC/SM).	DATE
For use of this form, see AR 25-30; the proponent agency is ODISC4.							
TO: (Forward to proponent of publication or form) (Include ZIP Code) U. S. Army TACOM Life Cycle Management Command ATTN: AMSTA-LC-LMPP/TECH PUBS 1 Rock Island Arsenal, Rock Island, IL 61299-7630						FROM: (Activity and location) (Include ZIP Code)	
PUBLICATION/FORM NUMBER TM 10-5430-267-13&P						DATE 15 April 2009	TITLE Oper & Field Maint Manual w/RPSTL for Tank, Fabric, Collape, 20K GAL, Model MPC-F-20K-22276
ITEM NO.	PAGE NO.	PARA-GRAPH	LINE NO. *	FIGURE NO.	TABLE NO.	RECOMMENDED CHANGES AND REASON (Provide exact wording of recommended changes, if possible).	
<i>*Reference to line numbers within the paragraph or subparagraph.</i>							
TYPED NAME, GRADE OR TITLE					TELEPHONE EXCHANGE/AUTOVON, PLUS EXTENSION		SIGNATURE

TO: (Forward direct to addressee listed in publication) U. S. Army TACOM Life Cycle Management Command ATTN: AMSTA-LC-LMPP/TECH PUBS 1 Rock Island Arsenal, Rock Island, IL 61299-7630	FROM: (Activity and location) (Include ZIP Code)	DATE
--	---	-------------

PART II – REPAIR PARTS AND SPECIAL TOOL LISTS AND SUPPLY CATALOGS/SUPPLY MANUALS

PUBLICATION NUMBER TM 10-5430-267-13&P				DATE 15 April 2009			TITLE Oper & Field Maint Manual w/RPSTL for Tank, 20K GAL, Model MPC-F-20K-22276	
PAGE NO.	COLM NO.	LINE NO.	NATIONAL STOCK NUMBER	REFERENCE NO.	FIGURE NO.	ITEM NO.	TOTAL NO. OF MAJOR ITEMS SUPPORTED	RECOMMENDED ACTION

PART III – REMARKS *(Any general remarks or recommendations, or suggestions for improvement of publications and blank forms. Additional blank sheets may be used if more space is needed.)*

--

TYPED NAME, GRADE OR TITLE	TELEPHONE EXCHANGE/AUTOVON, PLUS EXTENSION	SIGNATURE
----------------------------	--	-----------

By Order of the Secretary of the Army:

GEORGE W. CASEY, JR.
General, United States Army
Chief of Staff

Official:



JOYCE E. MORROW
Administrative Assistant to the
Secretary of the Army

0908403

Distribution:

To be distributed in accordance with the initial distribution number (IDN) 256994 requirements for TM 10-5430-267-13&P.

THE METRIC SYSTEM AND EQUIVALENTS

<p>Linear Measure</p> <p>1 Centimeter = 10 Millimeters = 0.01 Meters = 0.3937 Inches 1 Meter = 100 Centimeters = 1000 Millimeters = 39.37 Inches 1 Kilometer = 1000 Meters = 0.621 Miles</p> <p>Weights</p> <p>1 Gram = 0.001 Kilograms = 1000 Milligrams = 0.035 Ounces 1 Kilogram = 1000 Grams = 2.2 Pounds 1 Metric Ton = 1000 Kilograms = 1 Megagram = 1.1 Short Tons</p> <p>Liquid Measure</p> <p>1 Milliliter = 0.001 Liters = 0.0338 Fluid Ounces 1 Liter = 1000 Milliliters = 33.82 Fluid Ounces</p>	<p>Square Measure</p> <p>1 Sq Centimeter = 100 Sq Millimeters = 0.155 Sq Inches 1 Sq Meter = 10,000 Sq Centimeters = 10.76 Sq Feet 1 Sq Kilometer = 1,000,000 Sq Meters = 0.386 Sq Miles</p> <p>Cubic Measure</p> <p>1 Cu Centimeter = 1,000 Cu Millimeters = 0.06 Cu Inches 1 Cu Meter = 1,000,000 Cu Centimeters = 35.31 Cu Feet</p> <p>Temperature</p> <p>$5/9 (^{\circ}\text{F} - 32) = ^{\circ}\text{C}$ 212° Fahrenheit is equivalent to 100° Celsius 90° Fahrenheit is equivalent to 32.2° Celsius 32° Fahrenheit is equivalent to 0° Celsius $9/5 \text{ C}^{\circ} + 32 = \text{F}^{\circ}$</p>
--	--

APPROXIMATE CONVERSION FACTORS

To Change	To	Multiply By
Inches	Centimeters	2.540
Feet	Meters	0.305
Yards	Meters	0.914
Miles	Kilometers	1.609
Sq Inches	Sq Centimeters	6.451
Sq Feet	Sq Meters	0.093
Sq Yards	Sq Meters	0.836
Sq Miles	Sq Kilometers	2.590
Acres	Sq Hectometers	0.405
Cubic Feet	Cubic Meters	0.028
Cubic Yards	Cubic Meters	0.765
Fluid Ounces	Milliliters	29.573
Pints	Liters	0.473
Quarts	Liters	0.946
Gallons	Liters	3.785
Ounces	Grams	28.349
Pounds	Kilograms	0.454
Short Tons	Metric Tons	0.907
Pound-Feet	Newton-Meters	1.356
Pounds per Sq Inch	Kilopascals	6.895
Miles per Gallon	Kilometers per Liter	0.425
Miles per Hour	Kilometers per Hour	1.609

To Change	To	Multiply By
Centimeters	Inches	0.394
Meters	Feet	3.280
Meters	Yards	1.094
Kilometers	Miles	0.621
Sq Centimeters	Sq Inches	0.155
Sq Meters	Sq Feet	10.764
Sq Meters	Sq Yards	1.196
Sq Kilometers	Sq Miles	0.386
Sq Hectometers	Acres	2.471
Cubic Meters	Cubic Feet	35.315
Cubic Meters	Cubic Yards	1.308
Milliliters	Fluid Ounces	0.034
Liters	Pints	2.113
Liters	Quarts	1.057
Liters	Gallons	0.264
Grams	Ounces	0.035
Kilograms	Pounds	2.205
Metric Tons	Short Tons	1.102
Newton-Meters	Pound-Feet	0.738
Kilopascals	Pounds per Sq Inch	0.145
Kilometers per Liter	Miles per Gallon	2.354
Kilometers per Hour	Miles per Hour	0.621

PIN: 085361-000